

Univerza  
v Ljubljani  
Fakulteta  
*za gradbeništvo  
in geodezijo*

*Janova 2  
1000 Ljubljana, Slovenija  
telefon (01) 47 68 500  
faks (01) 42 50 681  
fgg@fgg.uni-lj.si*



Univerzitetni program Gradbeništvo,  
Konstrukcijska smer

Kandidat:

**Damjan Sekereš**

# **Statični izračun jeklenega trietažnega poslovnega objekta**

**Diplomska naloga št.: 418**

**Mentor:**  
prof. dr. Jože Korelc

**Somentor:**  
asist. dr. Peter Skuber

Ljubljana, 27. 5. 2011

## **IZJAVA O AVTORSTVU**

Skladno s 27. členom Pravilnika o diplomskem delu UL Fakultete za gradbeništvo in geodezijo,

Podpisani **DAMJAN SEKEREŠ** izjavljam, da sem avtor diplomske naloge z naslovom:  
**STATIČNI IZRAČUN JEKLENEGA TRIETAŽNEGA POSLOVNEGA OBJEKTA.**

Izjavljam, da prenašam vse materialne avtorske pravice v zvezi z diplomsko nalogo na UL, Fakulteto za gradbeništvo in geodezijo.

Noben del tega zaključnega dela ni bil uporabljen za pridobitev strokovnega naziva ali druge strokovne kvalifikacije na tej ali na drugi univerzi ali izobraževalni inštituciji.

Ljubljana, 10. 5. 2011

---

(podpis kandidata)

## **IZJAVE O PREGLEDU NALOGE**

Nalogo so si ogledali profesorji konstrukcijske smeri:

## **BIBLIOGRAFSKO – DOKUMENTACIJSKA STRAN Z IZVLEČKOM**

<b>UDK:</b>	<b>624.014.2:624.041(043.2)</b>
<b>Avtor:</b>	<b>Damjan Sekereš</b>
<b>Mentor:</b>	<b>prof. dr. Jože Korelc univ. dipl. ing. grad.</b>
<b>Somentor:</b>	<b>asist. dr. Peter Skuber univ. dipl. ing. grad.</b>
<b>Naslov:</b>	<b>Statični izračun jeklenega trietažnega poslovnega objekta</b>
<b>Obseg in oprema:</b>	<b>95 strani, 17 preglednic, 69 slik, 414 enačb</b>
<b>Ključne besede:</b>	<b>jeklena konstrukcija, sovprežna plošča, statični izračun</b>

### **Izvleček**

V diplomski nalogi je narejen statični izračun trietažnega poslovnega objekta. Nosilna konstrukcija je jeklena, sestavljena iz momentnih okvirjev v prečni smeri in iz okvirjev s centričnim povezjem v vzdolžni smeri. Medetažna plošča je sovprežna armiranobetonska plošča. Globalna analiza je narejena na prostorskem numeričnem modelu. Račun statičnih količin je narejen z elastično analizo po teoriji drugega reda z začetno geometrijsko nepopolnostjo. Notranje statične količine in dimenzioniranje sem izvedel s programom SCIA Engineer. Vplive na konstrukcijo sem določil v skladu z Evrokod standardi. Potresno obtežbo sem nadomestil z ekvivalentnimi silami z upoštevanjem naključne torzije. Dimenzioniral sem značilne spoje in izdelal dispozicijske načrte ter načrte tipičnih spojev.

---

**BIBLIOGRAPHIC – DOCUMENTALISTIC INFORMATION**

<b>UDC:</b>	<b>624.014.2:624.041(043.2)</b>
<b>Author:</b>	<b>Damjan Sekereš</b>
<b>Supervisor:</b>	<b>Ph. D. Jože Korelc B. S. in C. E.</b>
<b>Co-supervisor:</b>	<b>Assist. Ph. D. Peter Skuber B. S. in C. E.</b>
<b>Title:</b>	<b>Static calculation of three-storey office building</b>
<b>Notes:</b>	<b>95 pages, 17 tables, 69 pictures, 414 equations</b>
<b>Key words:</b>	<b>steel structure, composite plate, static calculation</b>

**Abstract**

This diploma paper explains a static calculation of a three-storey office building. The supporting construction is made of steel, composed of momentary frames in the transverse direction and of frames with the centric linkage in the longitudinal direction. The interstory slab is a composite RC slab. The global analysis was made according to the space numeric model. The static quantities calculations were made with the elastic analysis according to the second order theory with the starting geometric imperfection. I executed the inner static quantities and dimensioning with the program SCIA Engineer. The factors affecting the construction were set according to the Evrokod standards. The seismic loading was replaced with equivalent forces, considering the coincidental torsions. I dimensioned the characteristic joints and created the dispositional plans and the plans of typical joints.

## **ZAHVALA**

Za pomoč pri nastajanju diplomske naloge se zahvaljujem mentorju prof. dr. Jožetu Korelcu in somentorju asist. dr. Petru Skuberju za pomoč pri reševanju problemov, ki so se pojavili pri izdelavi diplomske naloge.

Zahvalil bi se tudi družini in prijateljem, ki so mi vsa leta študija stali ob strani ter pomagali, me podpirali in vzpodbujali.

---

**KAZALO VSEBINE**

<b>1</b>	<b>UVOD</b>	<b>1</b>
<b>2</b>	<b>TEHNIČNO POROČILO</b>	<b>2</b>
<b>2.1</b>	<b>Opis konstrukcije</b>	<b>2</b>
<b>2.2</b>	<b>Uporabljeni materiali</b>	<b>3</b>
<b>2.3</b>	<b>Arhitekturna zasnova objekta</b>	<b>3</b>
<b>2.4</b>	<b>Numerični model konstrukcije za statično analizo</b>	<b>4</b>
<b>2.5</b>	<b>Metoda izračuna notranjih sil</b>	<b>5</b>
<b>2.6</b>	<b>Dinamična analiza</b>	<b>5</b>
<b>2.7</b>	<b>Medetažna in strešna konstrukcija</b>	<b>5</b>
<b>2.8</b>	<b>Zavetrovanje</b>	<b>6</b>
<b>2.9</b>	<b>Fasada</b>	<b>6</b>
<b>2.10</b>	<b>Spoji</b>	<b>6</b>
<b>2.11</b>	<b>Temelji</b>	<b>6</b>
<b>2.12</b>	<b>Izdelava in montaža jeklene konstrukcije</b>	<b>6</b>
<b>2.13</b>	<b>Protikorozijska zaščita</b>	<b>7</b>
<b>3</b>	<b>DOLOČITEV OBTEŽBE</b>	<b>8</b>
<b>3.1</b>	<b>Stalna obtežba</b>	<b>8</b>
<b>3.1.1</b>	<b>Obtežba strehe</b>	<b>8</b>
<b>3.1.2</b>	<b>Obtežba medetažne konstrukcije</b>	<b>9</b>
<b>3.1.3</b>	<b>Obtežba fasade</b>	<b>9</b>

<b>3.2</b>	<b>Koristna obtežba</b>	<b>10</b>
3.2.1	Streha	10
3.2.2	Medetaža	10
<b>3.3</b>	<b>Obtežba snega</b>	<b>10</b>
3.3.1	Obtežba snega na strehi za trajna/začasna projektna stanja	10
<b>3.4</b>	<b>Obtežba vetra</b>	<b>11</b>
3.4.1	Izračun osnovne hitrosti vetra	11
3.4.2	Tlak vetra $w_e$ na zunanje ploskve	11
3.4.2.1	Koeficient zunanjega tlaka $c_{pe}$ za navpične stene	12
3.4.2.2	Koeficient zunanjega tlaka $c_{pe}$ za ravno streho	15
3.4.3	Tlak vetra $w_i$ na notranje ploskve	17
3.4.3.1	Koeficient notranjega tlaka $c_{pi}$ na navpične stene	17
3.4.3.2	Koeficient notranjega tlaka $c_{pi}$ na ravno streho	17
3.4.4	Vpliv vetra na zunanje ploskve v kombinaciji z notranjim srkom in pritiskom v smeri osi X in Y	18
3.4.5	Grafični prikaz obtežbe z vetrom	19
3.4.6	Učinek trenja vetra na ovoj stavbe	19
3.4.7	Primerjava med silo vetra in potresno silo	21
<b>3.5</b>	<b>Dinamična analiza</b>	<b>22</b>
3.5.1	Faktor obnašanja za vodoravne potresne vplive	22
3.5.2	Analiza modela konstrukcije po metodi z vodoravnimi potresnimi silami	23
3.5.2.1	Upoštevanje potresnega vpliva v smeri delovanja X in Y	24
3.5.2.2	Račun teže objekta po etažah	24



---

3.5.2.3	Določitev vodoravne potresne sile $F_i$ v etaži $i$	26
3.5.2.4	Upoštevanje naključne torzije pri metodi z vodoravnimi silami	28
3.6	Obtežne kombinacije	29
3.6.1	Mejno stanje nosilnosti	29
3.6.2	Mejno stanje uporabnosti	30
4	GLOBALNA ANALIZA	32
4.1	Globalna geometrijska nepopolnost	32
5	DIMENZIONIRANJE GLAVNE KONSTRUKCIJE	33
5.1	Mejno stanje nosilnosti	33
5.1.1	Momentni okvir	33
5.1.2	Okvir z centričnim povezjem	34
5.2	Mejno stanje uporabnosti	35
5.2.1	Momentni okvir	35
5.2.2	Okvir z centričnim povezjem	37
5.3	Kontrola medetažnih pomikov za potresno obtežbo	38
5.3.1	Momentni okvir	38
5.3.2	Okvir z centričnim povezjem	39
5.4	Posebna pravila za protipotresno gradnjo jeklenih konstrukcij	39
5.4.1	Momentni okvir	40
5.4.1.1	Dimenzioniranje nosilcev	41
5.4.1.2	Dimenzioniranje stebrov	45
5.4.2	Okvir z centričnim povezjem	50

<b>6</b>	<b>MEDETAŽNA KONSTRUKCIJA</b>	<b>52</b>
<b>6.1</b>	<b>Sovprežna plošča</b>	<b>52</b>
<b>6.1.1</b>	<b>Montažno stanje</b>	<b>52</b>
<b>6.1.2</b>	<b>Končno stanje</b>	<b>52</b>
<b>6.1.3</b>	<b>Potrebna armatura</b>	<b>53</b>
<b>6.2</b>	<b>Sovprežni nosilec IPE 270</b>	<b>54</b>
<b>6.2.1</b>	<b>Material</b>	<b>54</b>
<b>6.2.2</b>	<b>Obtežba</b>	<b>54</b>
<b>6.2.3</b>	<b>Montažno stanje</b>	<b>54</b>
<b>6.2.4</b>	<b>Sovprežno stanje</b>	<b>56</b>
<b>6.2.5</b>	<b>Zmanjšanje strižne nosilnosti čepov</b>	<b>58</b>
<b>7</b>	<b>FASADNA PODKONSTRUKCIJA</b>	<b>60</b>
<b>8</b>	<b>OCENA NOSILNOSTI TEMELJNIH TAL</b>	<b>64</b>
<b>8.1</b>	<b>Zasnova pasovnih temeljev</b>	<b>64</b>
<b>8.2</b>	<b>Obtežba na pasovne temelje</b>	<b>66</b>
<b>8.3</b>	<b>Preverjanje nosilnosti temeljnih tal</b>	<b>67</b>
<b>9</b>	<b>DIMENZIONIRANJE ZNAČILNIH SPOJEV</b>	<b>70</b>
<b>9.1</b>	<b>Momentni spoj prečke IPE 330 na krajni steber HEA 280</b>	<b>70</b>
<b>9.2</b>	<b>Momentni spoj prečke IPE 500 na zunanji steber HEA 280</b>	<b>76</b>
<b>9.3</b>	<b>Momentni spoj prečke IPE 360 na vmesni steber HEA 340</b>	<b>77</b>
<b>9.4</b>	<b>Momentni spoj prečke IPE 500 na vmesni steber HEA 340</b>	<b>78</b>

<b>9.5</b>	<b>Členkasti spoj sekundarnega nosilca na primarni nosilec</b>	<b>79</b>
<b>9.6</b>	<b>Spoj stebra HEB 500 na pasovni temelj</b>	<b>84</b>
<b>9.7</b>	<b>Priključek diagonale na steber HEA 280</b>	<b>89</b>
<b>10</b>	<b>ZAKLJUČEK</b>	<b>93</b>
<b>VIRI</b>		<b>94</b>

**KAZALO PREGLEDNIC**

Preglednica 1: Koeficient zunanjšega tlaka in obtežba vetra na navpične stene pri vetru v smeri osi X	14
Preglednica 2: Koeficient zunanjšega tlaka in obtežba vetra na navpične stene pri vetru v smeri osi Y	15
Preglednica 3: Koeficient zunanjšega tlaka in obtežba vetra na ravno streho pri vetru v smeri osi X in Y	16
Preglednica 4: Koeficient notranjšega srka in obtežba vetra na navpične stene pri vetru v smeri osi X in Y	17
Preglednica 5: Koeficient notranjšega srka in obtežba vetra na ravne strehe pri vetru v smeri osi X in Y	18
Preglednica 6: Skupni vpliv vetra (zunanji vpliv + notranji vpliv) pri vetru v smeri osi X in Y	18
Preglednica 7: Skupni vpliv vetra (zunanji vpliv + notranji vpliv) pri vetru v smeri osi X in Y	18
Preglednica 8: Skupni vpliv vetra (zunanji vpliv + notranji vpliv) pri vetru v smeri osi X in Y	18
Preglednica 9: Skupni vpliv vetra (zunanji vpliv + notranji vpliv) pri vetru v smeri osi X in Y	19
Preglednica 10: Izračunani faktorji $\delta$ za upoštevanje naključne torzije v smeri osi X in Y	28
Preglednica 11: Izračunane potresne sile $F_i$ za posamezne etaže v smeri osi X in Y	29
Preglednica 12: Izbrana globalna geometrijska nepopolnost v smeri osi X in Y	32
Preglednica 13: Reakcije na temelj za MSN	66
Preglednica 14: Reakcije na temelj za potresno obtežno kombinacijo	67

---

Preglednica 15 : Izpis kontrol iz SCIA Engineer za spoj prečke IPE 500 na zunanji steber HEA 280	77
Preglednica 16 : Izpis kontrol iz SCIA Engineer za spoj prečke IPE 360 na vmesni steber HEA 340	78
Preglednica 17 : Izpis kontrol iz SCIA Engineer za spoj prečke IPE 500 na vmesni steber HEA 340	79

## KAZALO SLIK

Slika 1: Tloris prve etaže poslovnega objekta	4
Slika 2: Vzdolžni prerez objekta	4
Slika 3: Numerični model konstrukcije za statično analizo	5
Slika 4: Prikaz sestave strešne konstrukcije	8
Slika 5: Prikaz sestave medetažne konstrukcije	9
Slika 6: Razporeditev tlakov v odvisnosti od referenčne višine $z_e$ [SIST EN 1991-1-4 2004]	13
Slika 7: Razdelitev sten na področja [SIST EN 1991-1-4 2004]	14
Slika 8: Razdelitev strehe na področja [SIST EN 1991-1-4 2004]	16
Slika 9: Shematski prikaz notranjega srka in tlaka na objektu [SIST EN 1991-1-4 2004]	17
Slika 10 : Skupni vpliv vetra v smeri osi X	19
Slika 11 : Skupni vpliv vetra v smeri osi Y	19
Slika 12: Trenje pri delovanju vetra v smeri osi X	20
Slika 13: Trenje pri delovanju vetra v smeri osi Y	21
Slika 14: Izbran statični sistem za določitev faktorja obnašanja v smeri osi X [SIST EN 1998-1 2005]	23
Slika 15: Izbran statični sistem za določitev faktorja obnašanja v smeri osi Y [SIST EN 1998-1 2005]	23
Slika 16: Zasnova modela za izračun potresne sile $F_i$	26
Slika 17: Ovojnica momentov $M_{Ed}$ [kNm] najbolj obremenjenega okvirja	33
Slika 18: Ovojnica prečnih sil $V_{Ed}$ [kN] najbolj obremenjenega okvirja	33
Slika 19: Ovojnica osnih sil $N_{Ed}$ [kN] najbolj obremenjenega okvirja	34

---

Slika 20: Ovojnica momentov $M_{Ed}$ [kNm] najbolj obremenjenega okvirja	34
Slika 21: Ovojnica prečnih sil $V_{Ed}$ [kN] najbolj obremenjenega okvirja	34
Slika 22: Ovojnica osnih sil $N_{Ed}$ [kN] najbolj obremenjenega okvirja	35
Slika 23: Ovojnica vertikalnih pomikov $u_z$ [mm] za MSU	35
Slika 24: Ovojnica vertikalnih pomikov $u_z$ [mm] zaradi koristne obtežbe	36
Slika 25: Ovojnica horizontalnih pomikov $u_x$ [mm] za MSU	36
Slika 26: Ovojnica horizontalnih pomikov $u_y$ [mm] za MSU	37
Slika 27: Ovojnica horizontalnih pomikov $u_x$ [mm] za potresno obtežno kombinacijo	38
Slika 28: Ovojnica horizontalnih pomikov $u_x$ [mm] za potresno obtežno kombinacijo	39
Slika 29: Shematski prikaz priključka prečka – zunanji steber	40
Slika 30: Shematski prikaz priključka prečka – notranji steber	40
Slika 31: Ovojnica notranjih sil $M_{Ed}$ [kNm] zaradi potresne obtežne kombinacije	41
Slika 32: Ovojnica notranjih sil $V_{Ed}$ [kN] zaradi gravitacijske obtežbe	41
Slika 33: Ovojnica notranjih sil $N_{Ed}$ [kN] zaradi potresne obtežne kombinacije	42
Slika 34: Ovojnica notranjih sil $M_{Ed}$ [kNm] zaradi gravitacijske obtežbe	45
Slika 35: Ovojnica notranjih sil $V_{Ed}$ [kN] zaradi gravitacijske obtežbe	45
Slika 36: Ovojnica notranjih sil $N_{Ed}$ [kN] zaradi gravitacijske obtežbe	45
Slika 37: Ovojnica notranjih sil $M_{Ed}$ [kNm] zaradi potresne obtežbe	46
Slika 38: Ovojnica notranjih sil $V_{Ed}$ [kN] zaradi potresne obtežbe	46
Slika 39: Ovojnica notranjih sil $N_{Ed}$ [kN] zaradi potresne obtežbe	46
Slika 40: Ovojnica notranjih sil $N_{Ed}$ [kN] za potresno obtežno kombinacijo	50

Slika 41: Zasnova sovprežnega nosilca	54
Slika 42: Geometrijske karakteristike sovprežnega prereza	56
Slika 43: Zasnova modela fasadne podkonstrukcije	60
Slika 44: Ovojnica notranjih sil $M_{Ed,y}$ [kNm] fasadne podkonstrukcije	61
Slika 45: Ovojnica notranjih sil $M_{Ed,z}$ [kNm] fasadne podkonstrukcije	61
Slika 46: Ovojnica vertikalnih pomikov $u_z$ [mm] fasadne podkonstrukcije	62
Slika 47: Ovojnica horizontalnih pomikov $u_y$ [mm] fasadne podkonstrukcije	62
Slika 48: Reakcije $R_z$ [kN] fasadne podkonstrukcije	63
Slika 49: Zasnova pasovnih temeljev	65
Slika 50: Prečni prerez pasovnega temelja	65
Slika 51 : Kontaktni tlaki $M_y$ [kNm] med temeljem in zemljino za MSN	67
Slika 52 : Kontaktni tlaki $V_z$ [kN] med temeljem in zemljino za MSN	67
Slika 53 : Kontaktni tlaki $N$ [kN] med temeljem in zemljino za MSN	67
Slika 54: Zasnova momentnega spoja prečka - steber	70
Slika 55: Razporeditev vijakov na spoju prečka - steber	70
Slika 56: Sodelujoča širina stojine stebra	73
Slika 57: Delovanje obremenitve na steber	73
Slika 58: Dodatna pločevina na stojini stebra	74
Slika 59: Prikaz zvara med čelno pločevino in profilom	75
Slika 60: Momentni spoj prečke IPE 500 na zunanji steber HEA 280	77
Slika 61: Momentni spoj prečke IPE 360 na vmesni steber HEA 340	77



---

Slika 62: Momentni spoj prečke IPE 500 na vmesni steber HEA 340	79
Slika 63: Zasnova členkastega spoja sekundarnega nosilca na primarni nosilec	80
Slika 64: Shematski prikaz obremenitve v ravnini 1-1	80
Slika 65: Shematski prikaz obremenitve v ravnini 2-2	82
Slika 66: Strižni pretrg na robu pločevine	83
Slika 67: Priključek stebra na temelj	84
Slika 68: Projektna ploskev raznosa obtežbe pri lokalni obtežbe [SIST EN 1992-1-1 2005]	86
Slika 69: Zasnova spoja diagonale na steber	89

## 1 UVOD

V gradbeni praksi je poleg klasične gradnje objektov prisoten trend montažne gradnje, ki nam prinaša veliko prednosti. Gradnja je hitra, objekt je predan naročniku v bistveno krajšem času kot v primeru klasične gradnje. Jeklena konstrukcija je lažja od betonske, zato je primerna za gradnje na slabše nosilnih tleh.

Samo jeklo kot gradbeni material ima lastnosti, ki omogočajo optimalne rešitve na področju estetike, neoporečen je tudi z ekonomskega, okoljskega, tehničnega in varnostnega vidika. Znan je kot material bogatih izraznih možnosti in pomembnih tehničnih lastnosti, kot so natezna trdnost, premoščanje velikih razponov, hitra in natančna gradnja, fleksibilnost in enostavno vzdrževanje. Jeklo omogoča uspešne kombinacije z drugimi materiali, predvsem s steklom, kar lahko daje poslovnim objektom posebno estetsko vrednost.

Zasnova konstrukcije temelji na arhitektonskih podlagah. Je oblike črke L in obsega tri etaže. Objekt je postavljen v Ljubljani. Nosilna konstrukcija je jeklena, sestavljena iz momentnih okvirjev v prečni smeri in iz okvirjev z centričnim povezjem v vzdolžni smeri. Razdalja med momentnimi okvirji je 5m. Medetažna plošča je sovprežna. Stavba je namenjena za poslovno dejavnost.

Obtežbo z vetrom v analizi ne upoštevam, saj je v primerjavi s potresno obtežbo manjša. Za določitev potresne obtežbe uporabim metodo z vodoravnimi silami. Pri dimenzioniranju so upoštevana posebna pravila za projektiranje objektov na potresnih območjih.

Analiza konstrukcije je narejena s programom SCIA Engineer. Izračun statičnih količin za mejno stanje nosilnosti in potresno analizo ter pomike za mejno stanje uporabnosti je narejen po teoriji drugega reda z upoštevanjem začetne geometrijske globalne nepopolnosti.

V okviru diplomske naloge so dimenzionirani spoji in preverjena je nosilnost temeljnih tal. Nosilnost spojev je določena s pomočjo programskega modula za izračun spojev in narejena kontrola po poenostavljeni računski metodi. Temelji so pasovni, modelirani na elastični podlagi z modulom reakcije tal.

## 2 TEHNIČNO POROČILO

### 2.1 Opis konstrukcije

Obravnavana konstrukcija je več etažna jeklena konstrukcija, ki je zasnovana iz:

- pasovnih temeljev,
- jeklenih stebrov,
- jeklenih nosilcev,
- medetažnih sovprežnih plošč in
- fasadne podkonstrukcije.

Obravnavan poslovni objekt je zasnovan tlorisno obliko v obliki črke L. Osnovni del ima dolžino 25m in širino 30m, priključni del pa dolžino 15m in širino 15m. Objekt obsega tri etaže, kjer je prva etaža visoka 3,2m ostali dve sta visoki 3,0m. Skupna višina objekta je 9,8m vključno s parapetom na strehi. Objekt je postavljen v Ljubljani in je namenjen poslovnim dejavnostim. Glavna nosilna konstrukcija je izvedena iz jekla kvalitete S235, medetažna in strešna konstrukcija sta iz armiranobetonske sovprežne plošče. Osnovno nosilno konstrukcijo objekta tvori 9 prečnih okvirjev na medsebojni razdalji 5m. Primarni nosilci okvirja se priključujejo na stebre z momentnim čelnim spojem. V vzdolžni smeri imam sedem okvirjev z vertikalnimi povezji. Streha je izvedena kot nepohodna z minimalnim naklonom. Na strehi je predvidena ozelenitev.

Za primarne stebre sem uporabil tri različne profile. Obodni stebri so HEA 280, notranji stebri v prvi etaži so HEB 500, v zgornjih dveh etažah pa HEA 340. Za primarne prečke sem uporabil profile IPE 330 v prvi etaži, IPE 360 v drugi etaži in IPE500 za tretjo etažo. Sekundarni jekleni nosilec, ki povezuje primarne okvirje in prenese obtežbo medetaže in strehe v stebre, je IPE 270 v medetaži in IPE 300 na strehi.

Na sekundarnih nosilcih leži armiranobetonska sovprežna plošča, skupne debeline 14cm. Nosilec in plošča sta povezana z Nelson mozniki, višine 10cm in premera 1,9cm. Pločevina za ploščo je tipa HI-Bond 55,  $t = 0,8\text{mm}$ ,  $f_y = 250\text{MPa}$ . Armaturna mreža nad podporami je R335, za raznos obtežbe se uporabi armaturna mreža Q257.

Fasadni paneli so TRIMO FTV<sub>GS</sub> debeline 20cm. Fasadni paneli so pritrjeni na fasadno podkonstrukcijo, sestavljeno iz profilov U100, ki so privijačeni na nosilne stebre HEA 280.

Talna plošča je debeline 15cm na utrjeni podlagi in ni predmet tega izračuna. Objekt ni podkleten.

Vsi spoji na montaži so vijáčeni. Stopnišče ni predmet tega izračuna.

## **2.2 Uporabljeni materiali**

Pri analizi konstrukcije sem uporabil kvaliteto jekla S235 v skladu s standardom SIST EN 1993-1-1:2005. Za spoje sem uporabil jeklo kvalitete S235 in vijake kvalitete 10.9. Uporabil sem tudi beton trdnostnega razreda C25/30 v skladu s standardom SIST EN 1992-1-1:2005 in jeklo za armiranje S500.

## **2.3 Arhitekturna zasnova objekta**

Objekt je moderna poslovna zgradba sestavljena iz pritličja in dveh nadstropij (P + 2). Objekt je zasnovan kot samostojni trietažni objekt v obliki črke L. Osnovni del je dimenzij 25m x 30m, priključni del pa 15m x 15m. Vsaka etaža ima 975m<sup>2</sup> bruto površine, kar nanese skupno 2925m<sup>2</sup> bruto površine.

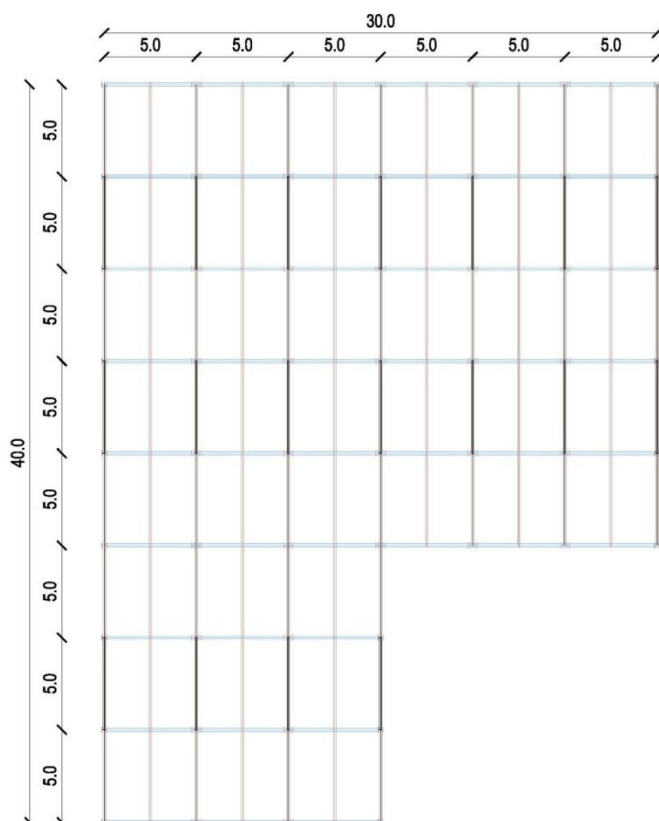

Slika 1: Tloris prve etaže poslovnega objekta

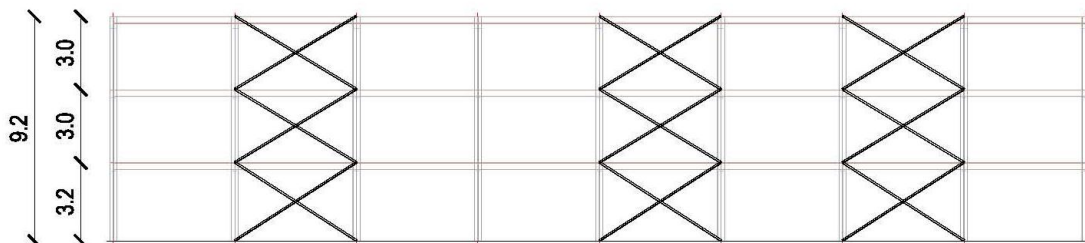

Slika 2: Vzdolžni prerez objekta

## 2.4 Numerični model konstrukcije za statično analizo

Spodnja slika prikazuje model konstrukcije, ki je bil uporabljen v analizi in oceni ustreznosti objekta v skladu z evropskimi standardi.

V osnovi je jekleni skelet s togimi sovprežnimi ploščami na nivoju etaž. Glavna nosilna konstrukcija je sestavljena iz momentnega okvirja v prečni smeri in okvirja s centričnimi povezji v vzdolžni smeri. Razmak med stebri je 5m tako v prečni kot tudi v vzdolžni smeri.

Okvirna konstrukcija preko sovprežnih plošč prevzame vso vertikalno in horizontalno obtežbo in jo prenaša na temelje. Temelji so pasovni, modelirani na elastični podlagi.

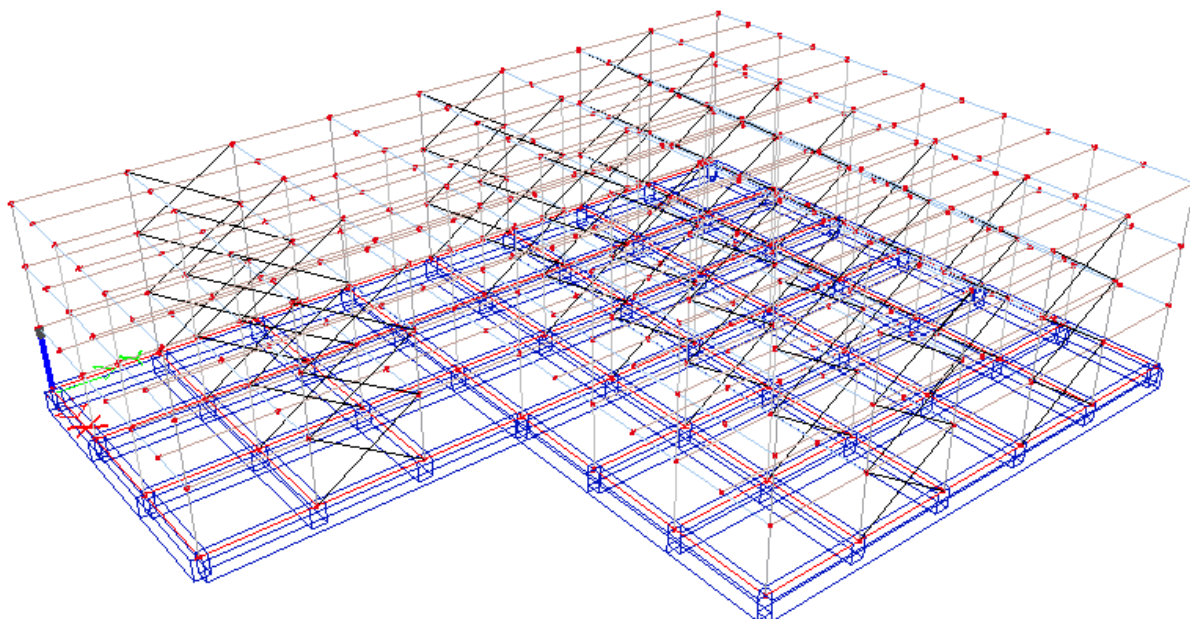

Slika 3: Numerični model konstrukcije za statično analizo

## 2.5 Metoda izračuna notranjih sil

Obračunan prostorski model je izračunan z računalniškim programom SCIA Engineer po teoriji drugega reda z upoštevanjem globalne geometrijske nepopolnosti.

Objekt je dimenzioniran po veljavnih Evrokod standardih.

## 2.6 Dinamična analiza

Dinamična analiza je opravljena po metodi nadomestnih vodoravnih sil z upoštevanjem naključne torzije. Projektni pospešek tal je  $0,25g$ .

Konstrukcija je projektirana po SIST EN 1998, tako da med potresom stebri ostanejo nepoškodovani, v prečkah glavnih okvirjev pa pride do plastifikacije. Preprečena je tlačna in strižna plastifikacija prečk. Elementi so dimenzionirani po 1. razredu kompaktnosti, faktorja obnašanja sta za prečno smer  $3,25$  za vzdolžno  $4$ .

## 2.7 Medetažna in strešna konstrukcija

Za medetažno konstrukcijo in strešno konstrukcijo sem izbral sovprežno armiranobetonsko ploščo, ki leži na sovprežnih nosilcih IPE 270. Primarne prečke so priključene na stebre preko

momentnega vijachenega stika. Sovprežni nosilci so pritrjeni členkasto. Armiranobetonska sovprežna plošča poteka v prečni smeri kontinuirano čez 4 polja razpona 5m. Na polovici objekta je plošča prekinjena z dilatacijo. Izbral sem sovprežno ploščo tipa HI-Bond 55,  $t = 0,8\text{mm}$ ,  $f_y = 250\text{MPa}$ . Nelson čepi  $\varnothing 19$ ,  $f_u = 45\text{kN/cm}^2$ .

## 2.8 Zavetrovanje

Zavetrovanje je izvedeno s škatlastimi profili. Izvede se ga v drugem, četrtem in šestem polju. Profili so členkasto pritrjeni na nosilne stebre. Zavetrovanje prevzame horizontalne sile v vzdolžni smeri.

## 2.9 Fasada

Na objektu je predvidena fasada trimo panel Trimoterm FTV<sub>GS</sub> debeline 20cm, ki je preko fasadne podkonstrukcije, lege U100 v vzdolžni in prečni smeri pritrjena na zunanje stebre. Maksimalni razmak med vijaki je 35cm. Fasadne plošče so zaščitene z zaščitnim in dekorativnim premazom.

## 2.10 Spoji

V diplomski nalogi so predstavljeni štiri različni spoji. Spoj prečke na steber, spoj sekundarnega nosilca na primarni nosilec, spoj stebra na temelj in spoj povezja na steber. Pri vseh spojih so izbrani vijaki 10.9, pri spoju stebra na temelj pa sidra kvalitete S355.

## 2.11 Temelji

Temelji so pasovni širine 0,7m in podpirajo zunanje stebre HEA 280 in notranje stebre HEB 500. Višina temeljev je 1m.

Temeljna tla so dobro nosilna. Kohezija je  $18\text{kN/m}^2$ , kot notranjega trenja je  $35^\circ$ , specifična teža zemljine  $20,5\text{kN/m}^3$  in nosilnost temeljnih tal  $1114\text{kN/m}^2$

## 2.12 Izdelava in montaža jeklene konstrukcije

Pri izdelavi konstrukcije je potrebno posebno pozornost posvetiti vozlišču med stebrom in nosilcem. Z ustrezno kontrolo je potrebno zagotoviti, da bo celotna konstrukcija narejena po predpisanih standardih.

Vsi čelni zvari, izvedeni v delavnici ali na montaži, morajo biti 1. kvalitete (SIST EN 1990 – 1). Detajli, ki potrebujejo posebno pozornost zaradi funkcije, so:

- zvari pri prekinitvi stebra (V zvar 1. kvalitete, polna penetracija)
- zvari pri stiku fasadnih leg (V zvar 1. kvalitete, polna penetracija)
- zvari pri čelni pločevini stika stebra na temelj (K zvar 1. kvalitete, polna penetracija)
- zvar pri čelni pločevini stika prečka steber (K zvar 1. kvalitete, polna penetracija)

Ob vseh dodatnih zvarih za stikovanje lamel, ki v projektu niso bili predvideni, je potrebno obvestiti projektanta, ki bo na osnovi lege in obremenitve zvara opravil klasifikacijo. Jeklena konstrukcija mora biti izdelana in montirana v skladu s projektno dokumentacijo, veljavnimi predpisi in standardi.

Pri montaži je potrebno s pravim vrstnim redom montaže zagotoviti stabilnost konstrukcije. Nujna je prisotnost nadzornega organa. Med montažo je potrebno zagotoviti prostorsko lego vozlišč (prostorska konstrukcija) in varjenje ter nanos protikorozijskih premazov.

Pri izdelavi posameznih elementov jeklene konstrukcije je potrebno pozornost posvetiti dimenzijski kontroli in pripravi zvarnih žlebov.

Med izdelavo in montažo jeklene konstrukcije mora biti zagotovljena stalna merska kontrola in stalen strokovni nadzor, ki ga izvaja strokovnjak za jeklene konstrukcije. Ob vsaki izvedeni spremembi je potrebno pridobiti pisno soglasje projektanta.

### **2.13 Protikorozijska zaščita**

Vsi jekleni elementi morajo biti protikorozijsko zaščiteni. Predlagam uporabo enega temeljnega in dveh prekrivnih premazov v skupni debelini suhega filma 0,15-0,20mm. Vsa poškodovana mesta je potrebno po montaži očistiti in protikorozijsko zaščiti. Pred nanosom temeljnega premaza morajo biti konstrukcijski elementi očiščeni s peskanjem.



### 3 DOLOČITEV OBTEŽBE

Med vplive na konstrukcijo sodijo vsi dejavniki obremenitev, ki so pomembni za obnašanje objekta. Vplive navadno ponazorimo s silami oziroma porazdeljeno obtežbo, ki predstavlja predviden vpliv na konstrukcijo. Ker je konstrukcija hkrati lahko izpostavljena različnim vplivom obtežbe, je potrebno upoštevati kritičen obtežni primer. Vplivi so določeni v skladu z evropskimi standardi za posamezno vrsto obremenitve. V diplomski nalogi sem se soočil z vplivi, katere sem razdelil na lastno težo, stalno obtežbo, koristno obtežbo, obtežbo snega in vetra ter potresno obtežbo.

#### 3.1 Stalna obtežba

##### 3.1.1 Obtežba strehe

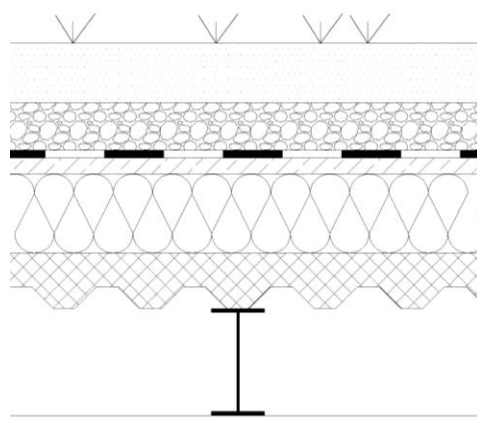

Slika 4: Prikaz sestave strešne konstrukcije

1	zemlja (15cm)	2,70kN/m <sup>2</sup>
2	filc (drenažni sloj)	
3	prodec (12cm)	1,80kN/m <sup>2</sup>
4	filc (ločilni sloj)	
5	hidroizolacija	0,18kN/m <sup>2</sup>
6	cementni estrih (4cm)	0,96kN/m <sup>2</sup>
7	parna zapora	
8	ekspandirani polistiren (20cm)	0,40kN/m <sup>2</sup>
9	HI-Bond sovprežna plošča (14cm)	2,91kN/m <sup>2</sup>
10	jekleni profili (upošteva program)	

11	inštalacije	0,20kN/m <sup>2</sup>
12	spuščen strop	0,10kN/m <sup>2</sup>

---

$$\Sigma G_s = 9,25\text{kN/m}^2$$

### 3.1.2 Obtežba medetažne konstrukcije

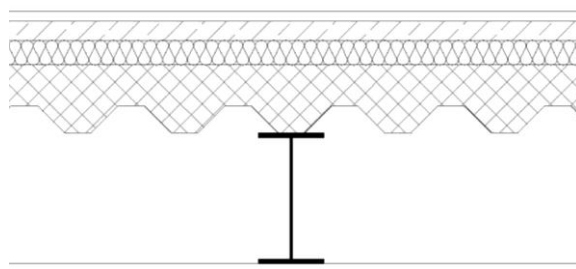

Slika 5: Prikaz sestave medetažne konstrukcije

1	zaključni sloj (2cm)	0,05kN/m <sup>2</sup>
2	cementni estrih (5cm)	1,25kN/m <sup>2</sup>
3	PVC folija	
4	ekspanzirani polistiren (5cm)	0,10kN/m <sup>2</sup>
5	HI-Bond sovprežna plošča (14cm)	2,91kN/m <sup>2</sup>
6	jekleni profili (upošteva program)	
7	inštalacije	0,20kN/m <sup>2</sup>
8	spuščen strop	0,10kN/m <sup>2</sup>

---

$$\Sigma G_m = 4,61\text{kN/m}^2$$

### 3.1.3 Obtežba fasade

1	fasadni paneli (20cm)	0,34kN/m <sup>2</sup>
2	fasadna podkonstrukcija	0,20kN/m <sup>2</sup>

---

$$\Sigma G_f = 0,54\text{kN/m}^2$$

## 3.2 Koristna obtežba

1. in 2. nadstropje je namenjeno pisarnam, streha je dostopna le za normalno vzdrževanje in popravilo.

### 3.2.1 Streha

- |                                   |                       |
|-----------------------------------|-----------------------|
| ▪ nepohodna streha (kategorija H) | 0,40kN/m <sup>2</sup> |
|-----------------------------------|-----------------------|

$$\Sigma Q_s = 0,4\text{kN/m}^2$$

### 3.2.2 Medetaža

- |                          |                       |
|--------------------------|-----------------------|
| ▪ pisarne (kategorija B) | 3,00kN/m <sup>2</sup> |
| ▪ predelne stene         | 1,25kN/m <sup>2</sup> |

$$\Sigma Q = 4,25\text{kN/m}^2$$

## 3.3 Obtežba snega

Na porazdelitev snega vplivajo lastnosti strehe ter drugi dejavniki, kot so:

- oblika strehe,
- toplotne lastnosti strehe,
- hrapavost površine strehe,
- količina toplote, generirane pod streho,
- sosednje stavbe,
- teren v okolici stavbe in
- krajevne podnebne razmere, zlasti prevetrenost, temperaturne spremembe in verjetnost padavin (tako dežja kot snega).

### 3.3.1 Obtežba snega na strehi za trajna/začasna projektna stanja

$$S = \mu_i * c_e * c_t * S_k$$

**Karakteristična vrednost obtežbe snega** se določi po spodnji enačbi, ki je prilagojena za posamezno cono v Sloveniji. Ker je obravnavan objekt lociran v Ljubljani, izberemo naslednjo enačbo:

$$s_k = 1,293 \left[ 1 + \left( \frac{A}{728} \right)^2 \right]$$

Osnova za zgoraj navedeno enačbo izhaja iz karte obtežbe snega, ki je razdeljena na štiri alpske in eno mediteransko cono. Na podlagi karte sem izbral cono A2.

$$s_k = 1,293 \left[ 1 + \left( \frac{298}{728} \right)^2 \right] = 1,51 \frac{kN}{m^2}$$

$$s = 0,8 * 1,0 * 1,0 * 1,51 \frac{kN}{m^2} = 1,21 \frac{kN}{m^2}$$

### 3.4 Obtežba vetra

#### 3.4.1 Izračun osnovne hitrosti vetra

Osnovna hitrost vetra se izračuna po naslednji enačbi:

$$v_b = c_{dir} * c_{season} * v_{b,0}$$

Na podlagi karte za vpliv vetra na konstrukcijo sem izbral cono 1, ki sicer zavzema večji del Slovenije, in temeljno vrednost osnovne hitrosti vetra  $V_{b,0}$ , ki znaša 20m/s v krajih z nadmorsko višino pod 800m.

$$v_b = 1,0 * 1,0 * 20 \frac{m}{s} = 20 \frac{m}{s}$$

#### 3.4.2 Tlak vetra $w_e$ na zunanje ploskve

Tlak vetra  $w_e$  na zunanje ploskve se izračuna po naslednji enačbi:

$$w_e = q_p(z_e) * c_{pe}$$

Največji tlak pri sunkih vetra  $q_p(z)$  se določi z naslednjo enačbo:

$$q_p(z) = [1 + 7 * l_v(z)] * \frac{1}{2} * \rho * v_m^2(z) = c_e(z) * q_b = 1,6964 * 250 = 424,1 \frac{N}{m^2}$$

$$q_p(z) = 0,4241 \frac{kN}{m^2}$$

Osnovni tlak vetra  $q_b$  se izračuna po naslednji enačbi:

$$q_b = \frac{1}{2} * \rho * v_b^2 = \frac{1}{2} * 1,25 \frac{kg}{m^3} * \left(20 \frac{m}{s}\right)^2 = 250 \frac{kg * m^2}{m^3 * s^2}$$

Faktor hrapavosti  $c_r(z)$  terena se izračuna po naslednji enačbi:

$$c_r(z) = k_r * \ln\left(\frac{z}{z_0}\right) \quad za \quad z_{min} \leq z \leq z_{max}; 5m \leq 9,8m \leq 200m$$

$$c_r(z) = 0,2154 * \ln\left(\frac{9,8}{0,3}\right) = 0,751$$

Faktor terena  $k_r$  se izračuna po spodnji enačbi. Za kategorijo terena predpostavimo, da imamo področje z običajnim rastlinjem ali stavbami ali s posameznimi ovirami na razdalji največ 20 višin ovir (vasi, podeželsko okolje, stalni gozd). Zaradi tega  $z_0$  izberem 0,3m, medtem ko za  $z_{o,II}$  izberem 0,05m.

$$k_r = 0,19 * \left(\frac{z_0}{z_{o,II}}\right)^{0,07} = 0,19 * \left(\frac{0,3}{0,05}\right)^{0,07} = 0,2154$$

Faktor izpostavljenosti  $c_e(z)$  se izračuna po naslednji enačbi:

$$c_e(z) = \left[1 + 7 * \frac{k_i * k_r}{c_0 * c_r}\right] * c_0^2 * c_r^2 = \left[1 + 7 * \frac{1,0 * 0,2154}{1,0 * 0,751}\right] * 1,0^2 * 0,751^2 = 1,6964$$

### 3.4.2.1 Koeficient zunanega tlaka $c_{pe}$ za navpične stene

Koeficient zunanega tlaka na stavbe s pravokotnim tlorisom je odvisen od velikosti površine delovanja obtežbe in je opredeljen na dva načina. Delovanje obtežbe na površino je lahko obravnavano kot globalno ali pa kot lokalno delovanje. Pri globalnem delovanju se osredotočimo na delovanje obtežbe na celoten objekt, ki ga označimo s koeficientom  $c_{pe,10}$ , kar pomeni, da je koeficient zunanega tlaka izračunan za površino delovanja obtežbe, večje ali enake  $10m^2$ , medtem ko je v določenih primerih potrebna tudi lokalna obravnava

koeficienta  $c_{pe,1}$ . To pomeni, da je koeficient zunanje tlaka izračunan za površino delovanja obtežbe, manjše ali enake  $1\text{m}^2$ . Ker ima obravnavan objekt velike površine, sem uporabil koeficiente zunanje tlaka  $c_{pe,10}$  z upoštevanjem linearne interpolacije, ki je odvisna od razmerja  $h/d$  za stene in linearno interpolacijo za ravne strehe, ki je odvisna od naklona ravne strehe. Za obravnavan objekt sem predpostavil, da je pravokotne oblike in upošteval pripadajoče koeficient za to obliko.

### **Koeficient zunjega tlaka pri delovanju vetra v smeri osi X**

Ker je razporeditev tlakov po višini odvisna od razmerja med višino in širino objekta, moramo ugotoviti, kakšen razpored tlakov imamo po objektu na sledeč način:

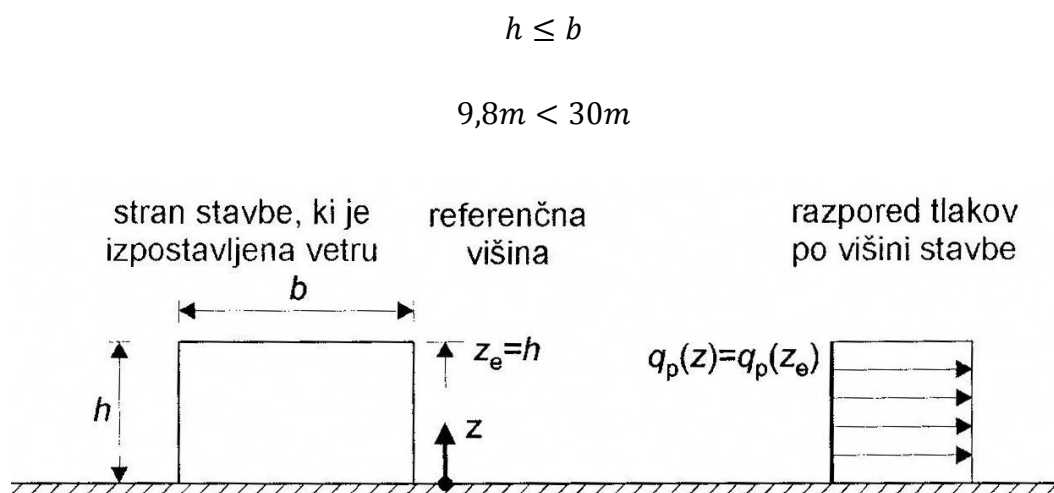

Slika 6: Razporeditev tlakov v odvisnosti od referenčne višine  $z_e$  [SIST EN 1991-1-4 2004]

Na podlagi izpolnjenega pogoja o razporeditvi konstantnih tlakov po višini je potrebna tudi razporeditev tlakov po celotnem ovoju stavbe na posamezna področja, ki se razdelijo od črke A do E. Ta področja so odvisna od geometrijskih karakteristik ovoja stavbe.

$$e < d$$

$$19,6\text{m} < 30\text{m}$$

$$e = \min\{b \text{ ali } 2 * h\} = \min\{40\text{m}; 2 * 9,8\text{m}\} = \min\{40\text{m}; \mathbf{19,6m}\}$$

$$\frac{e}{5} = \frac{19,6m}{5} = 3,92m$$

$$\frac{4}{5} * e = \frac{4}{5} * 19,6m = 15,68m$$

$$d - e = 30m - 19,6m = 10,4m$$

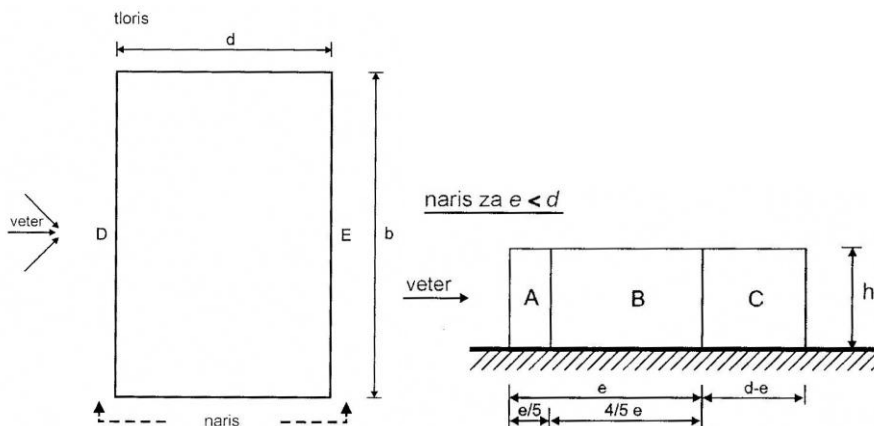

Slika 7: Razdelitev sten na področja [SIST EN 1991-1-4 2004]

Na podlagi razmerja  $h/d$  in z uporabo linearne interpolacije za posamezno področje sem uporabil naslednje rezultate koeficientov zunanje tlaka:

$$\frac{h}{d} = \frac{9,8m}{30m} = 0,3266$$

Preglednica 1: Koeficient zunanje tlaka in obtežba vetra na navpične stene pri vetru v smeri osi X

Področje	$q_p$	$c_{pe,10}$	$w_e$
A	0,4241	-1,2	-0,5089
B		-0,8	-0,3393
C		-0,5	-0,2121
D		0,7102	0,3012
E		-0,3204	-0,1359

### Koeficient zunje tlaka pri delovanju vetra v smeri osi Y

Ker je razporeditev tlakov po višini odvisna od razmerja med višino in širino objekta, moramo ugotoviti, kakšen razpored tlakov imamo po objektu na sledeč način:

$$h \leq b$$

$$9,8m < 40m$$

$$e < d$$

$$19,6m < 40m$$

$$e = \min\{b \text{ ali } 2 * h\} = \min\{30m; 2 * 9,8m\} = \min\{30m; 19,6m\}$$

$$\frac{e}{5} = \frac{19,6m}{5} = 3,92m$$

$$\frac{4}{5} * e = \frac{4}{5} * 19,6m = 15,68m$$

$$d - e = 40m - 19,6m = 20,4m$$

Na podlagi razmerja  $h/d$  in z uporabo linearne interpolacije za posamezno področje sem uporabil naslednje rezultate koeficientov zunanjskega tlaka:

$$\frac{h}{d} = \frac{9,8m}{40m} = 0,245$$

**Preglednica 2: Koeficient zunanjskega tlaka in obtežba vetra na navpične stene pri vetru v smeri osi Y**

Področje	$q_p$	$c_{pe,10}$	$w_e$
A	0,4241	-1,2	-0,5089
B		-0,8	-0,3393
C		-0,5	-0,2121
D		0,7	0,2969
E		-0,3	-0,1272

### 3.4.2.2 Koeficient zunanjskega tlaka $c_{pe}$ za ravno streho

#### Koeficient zunanjskega tlaka pri delovanju vetra v smeri osi X in Y

Za ravne strehe so koeficienti zunanjskega tlaka različni glede na področja, ki so označena s črkami od F do I. Ta področja se delijo podobno kot pri računu koeficientov za navpične stene ob upoštevanju določenih zahtev za ravne strehe. Obravnavana ravna streha ima naklon 3%,



kar predstavlja  $1,35^\circ$ . Po spodnjem postopku določim koeficiente zunanje tlaka za ravne strehe:

$$e = \min\{b_{\min} \text{ ali } 2 * h\} = \min\{30\text{m}; 2 * 9,8\text{m}\} = \min\{30\text{m}; \mathbf{19,6\text{m}}\}$$

$$\frac{e}{4} = \frac{19,6\text{m}}{4} = 4,9\text{m}$$

$$\frac{e}{10} = \frac{19,6\text{m}}{10} = 1,96\text{m}$$

$$\frac{e}{2} = \frac{19,6\text{m}}{2} = 9,8\text{m}$$

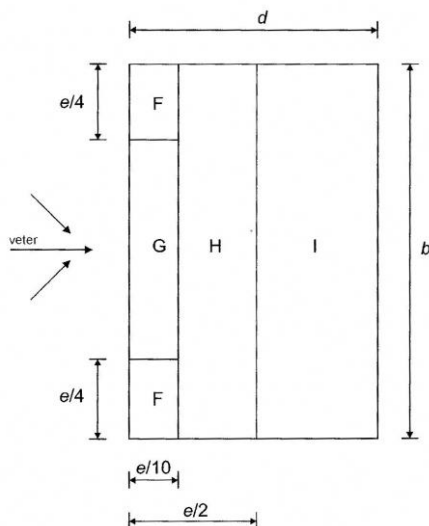

Slika 8: Razdelitev strehe na področja [SIST EN 1991-1-4 2004]

Za obtežbo vetra uporabim samo najbolj neugodno obliko obtežbe, kar je tlak po celotni površini strehe.

Preglednica 3: Koeficient zunanje tlaka in obtežba vetra na ravno streho pri vetru v smeri osi X in Y

Področje	$q_p$	$c_{pe,10}$	$w_e$
F	0,4241	-1,8	-0,7634
G		-1,2	-0,5089
H		-0,7	-0,2969
I		-0,2	-0,0848

### 3.4.3 Tlak vetra $w_i$ na notranje ploskve

Tlak vetra  $w_i$  na notranje ploskve se izračuna po naslednji enačbi:

$$w_i = q_p(z_i) * c_{pi}$$

#### 3.4.3.1 Koeficient notranjega tlaka $c_{pi}$ na navpične stene

Pri delovanju vetra je potrebno upoštevati sočasen vpliv notranjih in zunanjih tlakov. Ta vpliv upoštevamo takrat, kadar predpostavimo, da nam lahko odprtine v ovoju stavbe doprinesejo k prepustnosti in s tem k notranjim pritiskom oziroma srkom. Na podlagi tega je potrebno upoštevati najneugodnejšo kombinacijo zunanjih in notranjih tlakov. Notranji tlaki so odvisni predvsem od razporeditve odprtin na ovoju stavbe. Ker v mojem primeru ni mogoče določiti razmerje odprtin, se za koeficient notranjega tlaka  $c_{pi}$  privzame najneugodnejša vrednost med +0,2 in -0,3. Upoštevam le -0,3, saj povečuje notranji tlak vetra na strehi.

#### Koeficient notranjega tlaka pri delovanju vetra v smeri osi X in Y

Spodnja slika shematsko prikazuje srk oz. tlak na objektu.

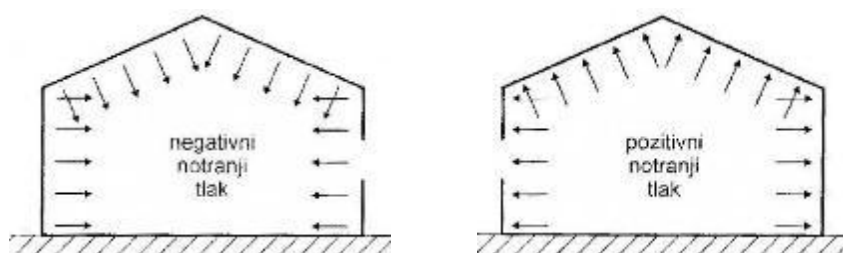

Slika 9: Shematski prikaz notranjega srka in tlaka na objektu [SIST EN 1991-1-4 2004]

Preglednica 4: Koeficient notranjega srka in obtežba vetra na navpične stene pri vetru v smeri osi X in Y

Področje	$q_p$	$c_{pi}$	$w_i$
A	0,4241	-0,3	-0,1272
B			-0,1272
C			-0,1272
D			-0,1272
E			-0,1272

#### 3.4.3.2 Koeficient notranjega tlaka $c_{pi}$ na ravno streho

Enako kot pri koeficientih notranjega tlaka za ravne strehe se upošteva najneugodnejša vrednost med 0,2 in -0,3. Upoštevam le -0,3, saj povečuje notranji tlak vetra na strehi.

**Koeficient notranjega tlaka pri delovanju vetra v smeri osi X in Y****Preglednica 5: Koeficient notranjega srka in obtežba vetra na ravne strehe pri vetru v smeri osi X in Y**

Področje	$q_p$	$c_{pi}$	$w_i$
F	0,4241	-0,3	-0,1272
G			-0,1272
H			-0,1272
I			-0,1272

**3.4.4 Vpliv vetra na zunanje ploskve v kombinaciji z notranjim srkom in pritiskom v smeri osi X in Y****Tlak vetra na navpičnih stenah**

Za tlak vetra na navpičnih stenah sem obravnaval najneugodnejše vrednosti v dveh primerih.

**PRIMER I****Preglednica 6: Skupni vpliv vetra (zunanji vpliv + notranji vpliv) pri vetru v smeri osi X in Y**

Področje	$w = w_e + w_i$
A	-0,6362
B	-0,4665
C	-0,3393
D	0,1740
E	-0,2631

**PRIMER II****Preglednica 7: Skupni vpliv vetra (zunanji vpliv + notranji vpliv) pri vetru v smeri osi X in Y**

Področje	$w = w_e + w_i$
A	-0,6362
B	-0,4665
C	-0,3393
D	0,1696
E	-0,2545

**Tlak vetra na ravni strehi**

Za tlak vetra na ravnih strehah sem obravnaval najneugodnejše vrednosti v dveh primerih.

**PRIMER I****Preglednica 8: Skupni vpliv vetra (zunanji vpliv + notranji vpliv) pri vetru v smeri osi X in Y**

Področje	$w = w_e + w_i$
F	-0,8906
G	-0,6362
H	-0,4241
I	-0,2121

**PRIMER II**

**Preglednica 9: Skupni vpliv vetra (zunanji vpliv + notranji vpliv) pri vetru v smeri osi X in Y**

Področje	$w = w_e + w_i$
F	-0,6786
G	-0,4241
H	-0,2121
I	0,0000

**3.4.5 Grafični prikaz obtežbe z vetrom**

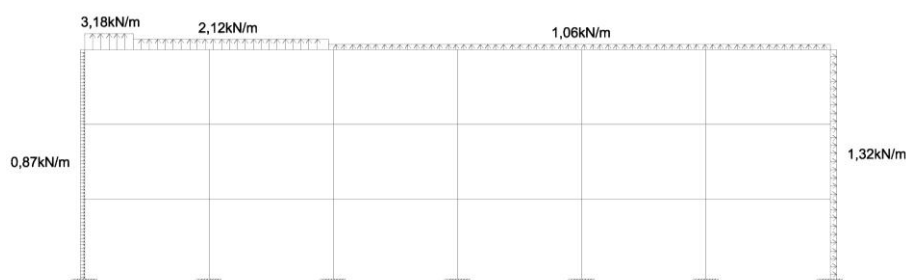

**Slika 10 : Skupni vpliv vetra v smeri osi X**

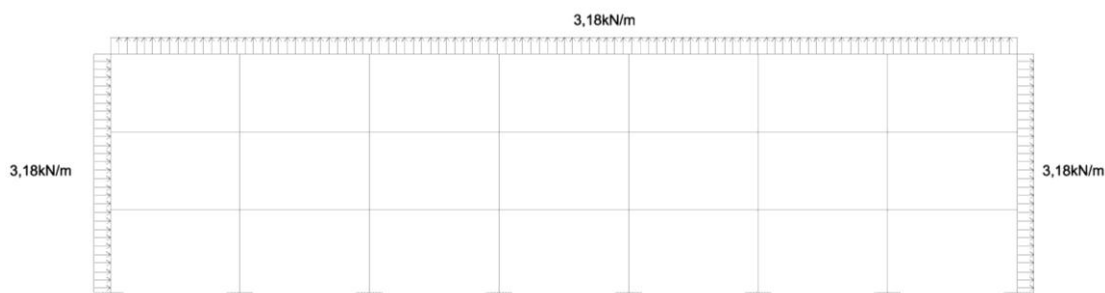

**Slika 11 : Skupni vpliv vetra v smeri osi Y**

**3.4.6 Učinek trenja vetra na ovoj stavbe**

Vpliv trenja na ovoj stavbe lahko zanemarimo tedaj, ko je celotna površina ploskev, vzporednih z vetrom, enaka ali manjša od štirikratne površine ploskev, ki so pravokotne na

vpliv vetra. Na podlagi te zahteve sem pregledal učinek trenja na ovoj stavbe privetrna v smeri osi X in smeri osi Y.

### Učinek trenja vetra na ovoj stavbe pri delovanju vetra v smeri osi X

$$A_v = A_1 + A_2 + A_3 + A_5 = 294m^2 + 147m^2 + 147m^2 + 975m^2$$

$$A_v = 1563m^2$$

$$A_p = A_4 + A_5 + A_6 = 392m^2 + 147m^2 + 245m^2$$

$$A_p = 784m^2$$

$$A_v \leq 4 * A_p$$

$$1563m^2 \leq 4 * 784m^2 = 3136m^2$$

Ker je celotna površina ploskev, vzporednih z vplivom vetra, manjša od štirikratne površine ploskev pravokotnih na vpliv, ni potrebno upoštevanje učinka trenja.

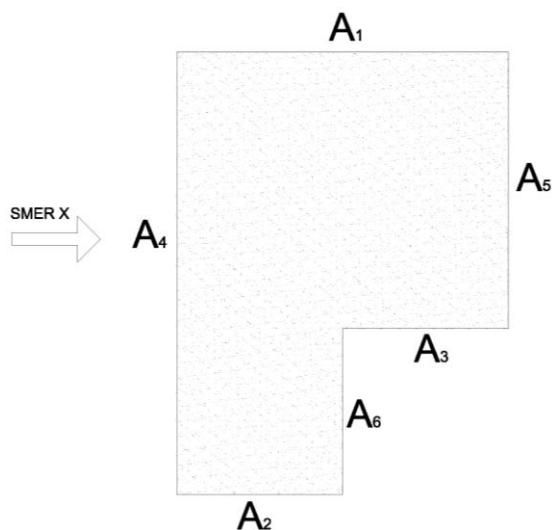

Slika 12: Trenje pri delovanju vetra v smeri osi X

### Učinek trenja vetra na ovoj stavbe pri delovanju vetra v smeri osi Y

$$A_v = A_4 + A_5 + A_6 + A_5 = 392m^2 + 147m^2 + 245m^2 + 975m^2$$

$$A_v = 1756m^2$$

$$A_p = A_1 + A_2 + A_3 = 294m^2 + 147m^2 + 147m^2$$

$$A_p = 588m^2$$

$$A_v \leq 4 * A_p$$

$$1756m^2 \leq 4 * 588m^2 = 2352m^2$$

Ker je celotna površina ploskev, vzporednih z vplivom vetra, manjša od štirikratne površine ploskev pravokotnih na vpliv, ni potrebno upoštevanje učinka trenja.

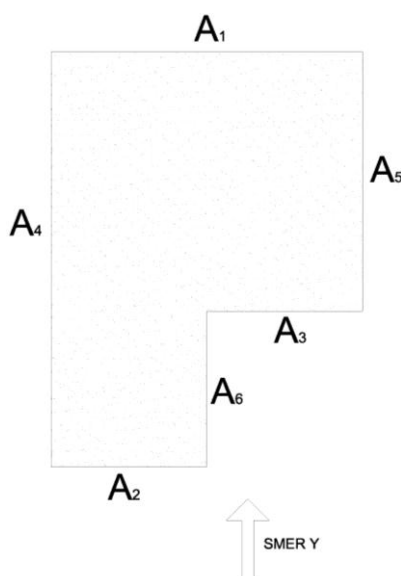

Slika 13: Trenje pri delovanju vetra v smeri osi Y

### 3.4.7 Primerjava med silo vetra in potresno silo

V primeru, da je potresna sila  $F_b'$ , ki vpliva na konstrukcijo, večja od vpliva obtežbe vetra  $F_w'$ , lahko le-to zanemarimo.

$$F_b' = a_g * S * \frac{2,5}{q} * m * \lambda = 0,25 * 9,81 \frac{m}{s^2} * 1,2 * \frac{2,5}{1} * 1982,61t * 0,85 = 12399,0kN$$

$$F_{wx} = w_{ex} * A_x = 0,3012 \frac{kN}{m^2} * 784m^2 = 236,1kN$$

$$F_{wy} = w_{ey} * A_y = 0,2969 \frac{kN}{m^2} * 588m^2 = 174,6kN$$

Potresna sila  $F_b'$  je merodajna obtežba, zato lahko vpliv obtežbe vetra zanemarimo.

### 3.5 Dinamična analiza

Potresna obtežba je določena z elastičnim spektrom pospeškov. Pri projektiranju na potresnih območjih je potrebno izpolniti zahtevo po neporušitvi in omejitvi poškodb. Pri delovanju potresne obtežbe dopustimo, da se konstrukcija poškoduje, vendar poškodbe omejimo do take mere, da ne pride do porušitve in s tem ne ogrozimo prebivalcev oziroma stanovalcev.

Sposobnost konstrukcijskega sistema, da prenaša potresne vplive v nelinearnem območju, na splošno dovoljuje, da se pri projektiranju uporabijo sile, ki so manjše od tistih, ki ustrezajo linearno-elastičnemu odzivu. Da bi se pri projektiranju izognili eksplicitni nelinearni analizi, se sposobnost konstrukcije, da sipa energijo predvsem z duktilnim obnašanjem njenih elementov in z drugimi mehanizmi, upošteva tako, da se opravi elastična analiza z reduciranim projektnim spektrom odziva. To zmanjšanje se izvede z uporabo faktorja obnašanja  $q$  [SIST EN 1998-1,2005, 3.2.2.5 Projektni spekter za elastično analizo, str.36].

Konstrukcije na potresnih območjih delimo na konstrukcije pravilne in nepravilne oblike. Zato moramo pri projektiranju parameter oblike posebej obravnavati, saj le-ta vpliva na model konstrukcije, metodo analize in vrednost faktorja obnašanja  $q$ . Na podlagi zahtev iz standarda SIST EN 1998-1 2005 sem ugotovil, da je obravnavan objekt tlorisno nepravilen in pravilen po višini. Na podlagi tega uporabim dovoljeno poenostavitev, kar pomeni, da lahko obravnavam objekt s prostorskim modelom z upoštevanjem metode z vodoravnimi silami.

#### 3.5.1 Faktor obnašanja za vodoravne potresne vplive

##### Faktor obnašanja $q$ v smeri osi X

Ker je predvideno, da je konstrukcija sposobna sipanja energije v duktilnem razredu DCH (visoka stopnja duktilnosti), se pri stavbah, ki so tlorisno nepravilne, uporabi za  $\alpha_u/\alpha_1$  polovična vrednost.

$$q = 5 * \frac{\alpha_u}{\alpha_1} = 5 * 0,5 * 1,3 = 3,25$$

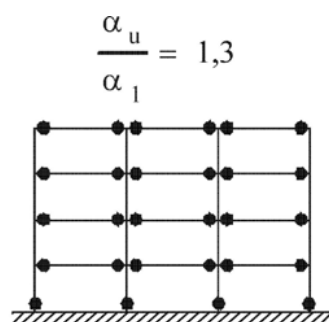

Slika 14: Izbran statični sistem za določitev faktorja obnašanja v smeri osi X [SIST EN 1998-1 2005]

### Faktor obnašanja q v smeri osi Y

Ker je konstrukcija v smeri osi Y sestavljena iz okvirjev z centričnimi povezji (diagonalna povezja), se za faktor obnašanja q privzame:

$$q = 4$$

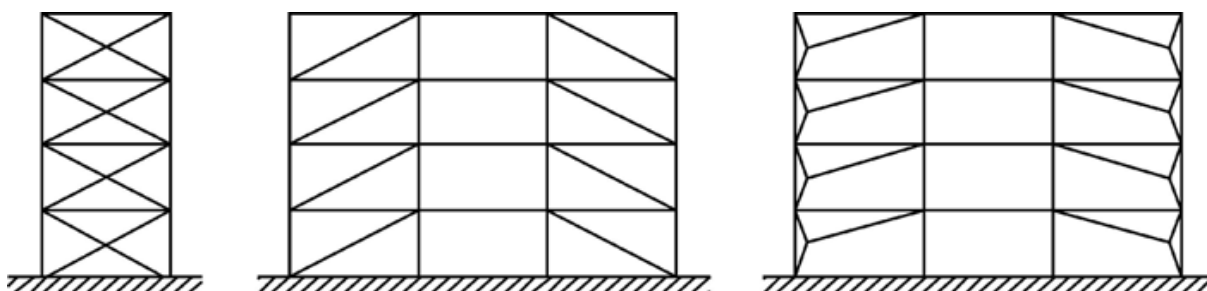

Slika 15: Izbran statični sistem za določitev faktorja obnašanja v smeri osi Y [SIST EN 1998-1 2005]

### 3.5.2 Analiza modela konstrukcije po metodi z vodoravnimi potresnimi silami

To vrsto analize sem uporabil, ker višje nihajne oblike v nobeni od glavnih smeri ne vplivajo pomembno na odziv. Upošteva se, da je zahteva tega pogoja izpolnjena, če stavbe ustrezajo pogojema:

- a) Osnovne nihajne čase  $T$  imajo v dveh glavnih smereh manjše od naslednjih vrednosti:

$$T_1 \leq \begin{cases} 4 * T_c = 4 * 0,5s = 2,0s \\ 2,0s \end{cases}$$

$$T_x = c_t * H^{3/4} = 0,085 * (9,8m)^{3/4} = 0,471s$$

$$T_y = c_t * H^{3/4} = 0,05 * (9,8m)^{3/4} = 0,277s$$



$c_t$ .....0,085 za prostorske jeklene momentne okvirje

$c_t$ .....0,05 za vse druge konstrukcije

- b) Ustrežajo merilom za pravilnost po višini, ki so navedeni v SIST EN 1998-1-2005 poglavje 4.2.3.3.

### 3.5.2.1 Upoštevanje potresnega vpliva v smeri delovanja X in Y

Metodo z vodoravnimi potresnimi silami sem izvedel s programom SCIA Engineer. Pri določanju projektnega potresnega vpliva je treba upoštevati mase, povezane z vsemi težnostnimi silami, ki so vključene v naslednji kombinaciji vplivov:

$$\sum G_{k,j} + \sum \Psi_{E,i} * Q_{k,i}$$

Kombinacijski koeficient za spremenljiv vpliv za račun učinkov potresnega vpliva se izračuna na naslednji način:

$$\Psi_{E,i} = \varphi * \Psi_{2,i}$$

$\varphi = 1,0$ .....za vrhno etažo;

$\varphi = 0,5$ .....vse ostale etaže, ki so neodvisno zasedene;

$\Psi_{2,i} = 0,0$ .....za strehe;

$\Psi_{2,i} = 0,3$ .....za pisarne

Ker je lahko učinek potresnega vpliva zaradi delovanja potresa v smer X in Y sočasen, kar pomeni, da vpliv potresa ne deluje točno v smeri X, ampak lahko še delno v smeri Y, upoštevamo potresni vpliv v programu SCIA Engineer na sledeč način:

$$E_{E,dx} + 0,30 * E_{E,dy}$$

$$0,30 * E_{E,dx} + E_{E,dy}$$

### 3.5.2.2 Račun teže objekta po etažah

Pri izračunu teže upoštevam, da so vse teže skoncentrirane v nivojih etaž.

**Teža na koti +9,20m ( $h_{et}^{III} = 3,00m$ )**

Stalna obtežba:

- zelena streha ( $g_s = 9,25kN/m^2$ ;  $h = 60cm$ )  $975m^2 * 9,25 \frac{kN}{m^2} = 9018,8kN$
  - fasada v II. nadstropju ( $g_f = 0,54kN/m^2$ )  $140m' * 1,5m * 0,54 \frac{kN}{m^2} = 113,4kN$
- $G_{III} = 9132,2kN$

Spremenljiva obtežba:

- sneg ( $q = 1,21kN/m^2$ ) se ne kombinira s potresom

Skupna teža v višini strešnega nosilca:

- $m_{III} = G_{III} = 9132,2kN = 913,22t$

**Teža na koti +6,20m ( $h_{et}^{II} = 3,00m$ )**

Stalna obtežba:

- medetažna plošča ( $g_m = 5,86kN/m^2$ )  $975m^2 * 4,61 \frac{kN}{m^2} = 4494,8kN$
  - fasada v II. nadstropju ( $g_f = 0,54kN/m^2$ )  $140m' * 1,5m * 0,54 \frac{kN}{m^2} = 113,4kN$
  - fasada v I. nadstropju ( $g_f = 0,54kN/m^2$ )  $140m' * 1,5m * 0,54 \frac{kN}{m^2} = 113,4kN$
- $G_{II} = 4721,6kN$

Spremenljiva obtežba:

- bivalni prostori ( $q = 3,0kN/m^2$ )  $975m^2 * 3,0 \frac{kN}{m^2} = 2925,0kN$
  - predelne stene ( $q = 1,25kN/m^2$ )  $975m^2 * 1,25 \frac{kN}{m^2} = 1218,8kN$
- $Q_{II} = 4143,8kN$

Skupna teža na višini +6,00m:

- $m_{II} = G_{II} + 0,5 * 0,3 * Q_{II} = 5343,2kN = 534,32t$

### Teža na koti +3,20m ( $h_{et}^I = 3,20m$ )

Stalna obtežba:

- medetažna plošča ( $g_m = 5,86kN/m^2$ )  $975m^2 * 4,61 \frac{kN}{m^2} = 4494,8kN$
  - fasada v I. nadstropju ( $g_f = 0,54kN/m^2$ )  $140m' * 1,5m * 0,54 \frac{kN}{m^2} = 113,4kN$
  - fasada v pritličju ( $g_f = 0,54kN/m^2$ )  $140m' * 1,6m * 0,54 \frac{kN}{m^2} = 121,0kN$
- $G_I = 4729,2kN$

Spremenljiva obtežba:

- bivalni prostori ( $q = 3,0kN/m^2$ )  $975m^2 * 3,0 \frac{kN}{m^2} = 2925,0kN$
  - predelne stene ( $q = 1,25kN/m^2$ )  $975m^2 * 1,25 \frac{kN}{m^2} = 1218,8kN$
- $Q_I = 4143,8kN$

Skupna teža na višini +3,00m:

- $m_I = G_I + 0,5 * 0,3 * Q_I = 5350,7kN = 535,07t$

### Celotna teža objekta

$$m = m_I + m_{II} + m_{III} = 1982,61t$$

#### 3.5.2.3 Določitev vodoravne potresne sile $F_i$ v etaži $i$

##### Zasnova in statični model

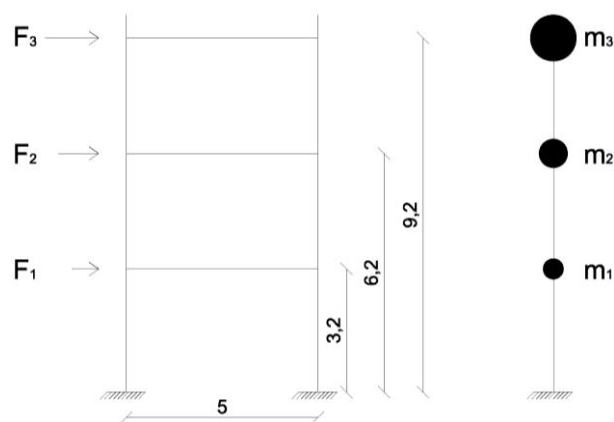

Slika 16: Zasnova modela za izračun potresne sile  $F_i$

**Potresna obremenitev  $F_i$** 

Skupna potresna sila  $F_i$  je določena po metodi z vodoravnimi silami. Predpostavimo, da so temeljna tla tipa B, kar pomeni, da so tla sestavljena ali iz zelo gostega peska, proda ali iz zelo toge gline, debeline vsaj nekaj deset metrov, pri katerih mehanske značilnosti z globino postopoma naraščajo. Nihajni čas konstrukcije je med nihajno dobo  $T_B$  in  $T_C$ . Na podlagi tega sem izračunal projektni spekter  $S_d(T)$  za elastično analizo v smeri osi X in Y, ki je določen z naslednjo enačbo:

$$S_d(T_x) = a_g * S * \frac{2,5}{q} = 0,25g * 1,2s * \frac{2,5}{3,25} = 0,2307g$$

$$S_d(T_y) = a_g * S * \frac{2,5}{q} = 0,25g * 1,2s * \frac{2,5}{4} = 0,1875g$$

Nihajni čas konstrukcije  $T_x = 0,471s$ ,  $T_y = 0,277s$ , in se vrednost spektra spreminja glede na obe smeri. Za izbran tip tal B je faktor tal  $S = 1,2s$ , medtem ko sta  $T_B$  in  $T_C$  enaka 0,15s oz. 0,5s. Projektni pospešek tal  $a_g$  je odvisen od lokacije objekta. Ker je objekt lociran v Ljubljani, je projektni pospešek tal 0,25g.

**Celotna potresna sila  $F_i$  za obravnavano smer**

- Potresna sila v smeri osi X

$$F_{ix} = S_d(T_x) * m * \lambda = 0,2307 * 9,81 \frac{m}{s^2} * 1982,61t * 0,85 = 3813,9kN$$

$$F_{1x} = F_{ix} * \frac{z_1 * m_I}{\sum_{i=1}^3 m_I * z_i} = 3813,9kN * \frac{3,2m * 5350,7kN}{128066,32kNm} = 509,9kN$$

$$F_{2x} = F_{ix} * \frac{z_2 * m_{II}}{\sum_{i=1}^3 m_I * z_i} = 3813,9kN * \frac{6,2m * 5343,2kN}{128066,32kNm} = 986,6kN$$

$$F_{3x} = F_{ix} * \frac{z_3 * m_{III}}{\sum_{i=1}^3 m_I * z_i} = 3813,9kN * \frac{9,2m * 9132,2kN}{128066,32kNm} = 2317,4kN$$

- Potresna sila v smeri osi Y

$$F_{iy} = S_d(T_y) * m * \lambda = 0,1875 * 9,81 \frac{m}{s^2} * 1982,61t * 0,85 = 3099,7kN$$

$$F_{1y} = F_{iy} * \frac{z_1 * W_I}{\sum_{i=1}^3 W_I * z_1} = 3099,7kN * \frac{3,2m * 5350,7kN}{128066,32kNm} = 414,4kN$$

$$F_{2y} = F_{iy} * \frac{z_2 * W_{II}}{\sum_{i=1}^3 W_I * z_1} = 3099,7kN * \frac{6,2m * 5343,2kN}{128066,32kNm} = 801,8kN$$

$$F_{3y} = F_{iy} * \frac{z_3 * W_{III}}{\sum_{i=1}^3 W_I * z_1} = 3099,7kN * \frac{9,2m * 9132,2kN}{128066,32kNm} = 1883,5kN$$

$\lambda$ .....korekcijski faktor, ki ima vrednost  $\lambda = 0,85$  za objekte s 3. ali več etažami

### 3.5.2.4 Upoštevanje naključne torzije pri metodi z vodoravnimi silami

Ker je razporeditev vodoravnih togosti in mas simetrična, je mogoče upoštevati vpliv naključne torzije tako, da se povečajo učinki vpliva v posameznih nosilnih elementih, pri katerih se posamezna potresna sila pomnoži s faktorjem  $\delta$  po enačbi:

$$\delta = 1 + 0,6 * \frac{x}{L_e}$$

Naključna torzija se upošteva za obe smeri (X in Y). Podatki so predstavljeni v naslednji tabeli:

**Preglednica 10: Izračunani faktorji  $\delta$  za upoštevanje naključne torzije v smeri osi X in Y**

$\delta_{x_1}$	1,2567	$\delta_{y_1}$	1,2654
$\delta_{x_2}$	1,1817	$\delta_{y_2}$	1,1654
$\delta_{x_3}$	1,1067	$\delta_{y_3}$	1,0654
$\delta_{x_4}$	1,0317	$\delta_{y_4}$	1,0346
$\delta_{x_5}$	1,0433	$\delta_{y_5}$	1,1346
$\delta_{x_6}$	1,1183	$\delta_{y_6}$	1,2346
$\delta_{x_7}$	1,1933	$\delta_{y_7}$	1,3346
$\delta_{x_8}$	1,2683		
$\delta_{x_9}$	1,3433		

### Razdelitev potresne sile $F_i$ na posamezne okvirje

Razdelitev potresnih sil na objekt je prikazana v spodnji tabeli:

**Preglednica 11: Izračunane potresne sile  $F_i$  za posamezne etaže v smeri osi X in Y**

	1 Nadstropje	2 Nadstropje	Streha
$F_{x1}$	49,29	95,38	224,03
$F_{x2}$	92,70	179,37	421,31
$F_{x3}$	86,82	167,98	394,58
$F_{x4}$	80,94	156,60	367,84
$F_{x5}$	81,84	158,35	371,95
$F_{x6}$	65,79	127,30	299,02
$F_{x7}$	46,80	90,56	212,71
$F_{x8}$	49,75	96,25	226,08
$F_{x9}$	26,34	50,97	119,73
$F_{y1}$	53,78	104,06	244,45
$F_{y2}$	99,06	191,67	450,26
$F_{y3}$	90,56	175,23	411,62
$F_{y4}$	71,46	138,26	324,78
$F_{y5}$	60,28	116,63	273,98
$F_{y6}$	65,59	126,91	298,13
$F_{y7}$	35,45	68,60	161,14

### 3.6 Obtežne kombinacije

#### 3.6.1 Mejno stanje nosilnosti

Pri projektiranju po mejnih stanjih nosilnosti je potrebno preveriti kombinacije vplivov za stalna in začasna projektna stanja ter kombinacije vplivov za potresna projektna stanja.

Kombinacije vplivov za stalna in začasna projektna stanja se določijo po naslednji enačbi:

$$\sum_{j \geq 1} \gamma_{G,j} * G_{k,j} + \gamma_{Q,1} * Q_{k,1} + \sum_{i \geq 1} \gamma_{Q,i} * \Psi_{0,i} * Q_{k,i}$$

Za kontrolo mejnega stanja nosilnosti upoštevam naslednje obtežne kombinacije:

1.  $1,35G + 1,5Q_1 + 0,75Q_s$
2.  $1,35G + 1,5Q_2 + 0,75Q_s$
3.  $1,35G + 1,5Q_3 + 0,75Q_s$

kjer so:

G.....stalna in lastna obtežba

$Q_1$ .....koristna obtežba (upoštevana po celotnem tlorisu)

$Q_2$ .....koristna obtežba (razporeditev obtežbe v obliki šahovnice)

$Q_3$ .....koristna obtežba (razporeditev obtežbe v obliki šahovnice, vendar drugačna razporeditev kot pri  $Q_2$ )

$Q_s$ .....obtežba snega

Kombinacije vplivov za potresna projektna stanja se določi po naslednji enačbi:

$$\sum_{j \geq 1} G_{k,j} + A_{Ed} + \sum_{i \geq 1} \Psi_{2,i} * Q_{k,i}$$

Za kontrolo potresnega projektne stanja upoštevam naslednje kombinacije:

1.  $1,0G + 1,0A_x + 0,3A_y$

2.  $1,0G + 0,3A_x + 1,0A_y$

$A_x$ .....potresna obtežba v smeri osi X

$A_y$ .....potresna obtežba v smeri osi Y

### 3.6.2 Mejno stanje uporabnosti

Mejnega stanja uporabnosti ne smemo preseči, in sicer to dokažemo tako, da omejimo deformacije, upogibe in vibracije.

Osnovna kombinacija za mejno stanje nosilnosti:

$$1,0G + \psi_1 * Q_k + \sum_{i > 1} \psi_{2,i} * Q_i$$

Za kontrolo mejnega stanja uporabnosti upoštevam naslednje obtežne kombinacije:

1.  $1,0G + 1,0Q_1 + 0,5Q_s$

2.  $1,0G + 1,0Q_2 + 0,5Q_s$

3.  $1,0G + 1,0Q_3 + 0,5Q_s$

4.  $1,0Q_1 + 0,5Q_s$

5.  $1,0Q_2 + 0,5Q_s$

6.  $1,0Q_3 + 0,5Q_s$



## 4 GLOBALNA ANALIZA

Za izvedbo statične analize celotne konstrukcije sem uporabil program Scia Engineer. Notranje statične količine in dimenzioniranje sem izvedel na prostorskem modelu z linijskimi elementi. Analiza konstrukcije je bila opravljena po teoriji II. reda z upoštevanjem geometrijske globalne nepopolnosti objekta. Toga šipa je modelirana s togimi povezami vozlišč v ravnini posamezne etaže. Temelji so modelirani z linijskimi elementi na elastični podlagi. Karakteristike plastičnih vzmeti so določene z modulom reakcije tal.

### 4.1 Globalna geometrijska nepopolnost

Pri analizi sem upošteval vse nepopolnosti, ki se lahko pojavijo pri izdelavi in montaži.

$$\phi = \phi_0 * k_c * k_s$$

$$\phi_0 = \frac{1}{200}$$

$$k_c = \sqrt{\left(0,5 + \frac{1}{n_c}\right)} \leq 1,0$$

$$k_s = \sqrt{\left(0,2 + \frac{1}{n_s}\right)} \leq 1,0$$

Preglednica 12: Izbrana globalna geometrijska nepopolnost v smeri osi X in Y

$k_{c,x}$	$k_{c,y}$	$k_{s,x}$	$k_{s,y}$	$\phi_x$ [mm/m]	$\phi_y$ [mm/m]
0,802	0,782	0,730	0,730	2,93	2,85



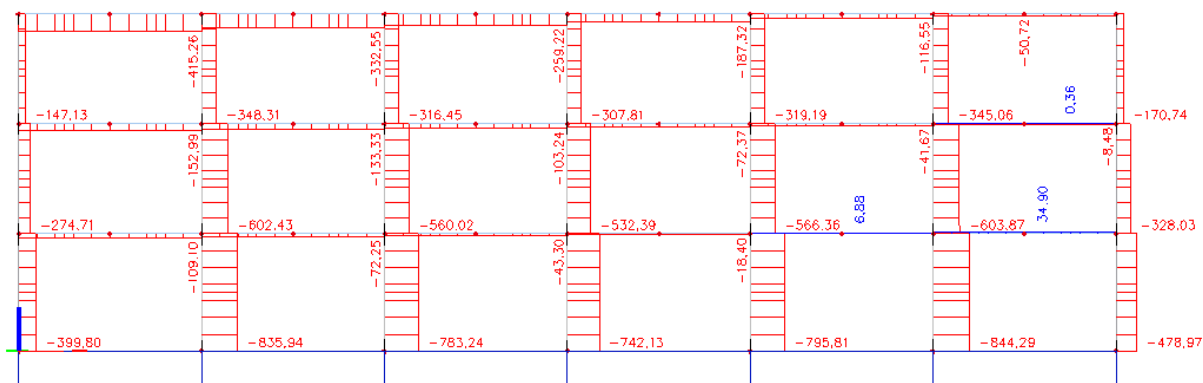

Slika 19: Ovojnica osnih sil  $N_{Ed}$  [kN] najbolj obremenjenega okvirja

### Dimenzioniranje stebrov in prečk

Dimenzioniranje in kontroliranje stebrov in prečk sem izvedel s programom SCIA Engineer. Vsi rezultati in kontrole so v prilogi A.

### 5.1.2 Okvir z centričnim povezjem

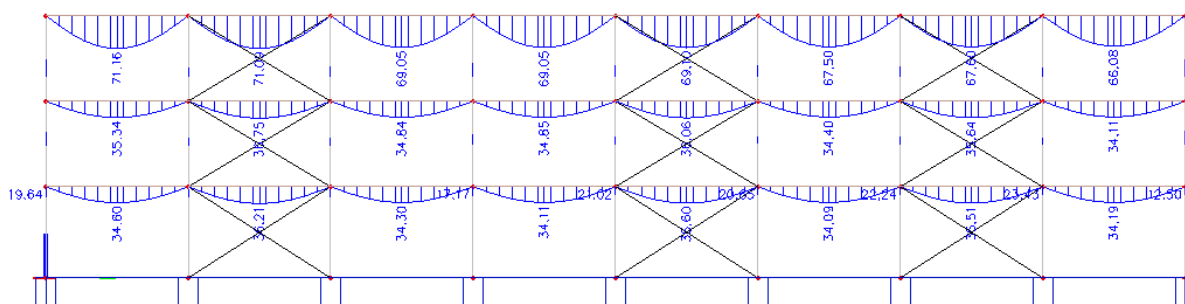

Slika 20: Ovojnica momentov  $M_{Ed}$  [kNm] najbolj obremenjenega okvirja

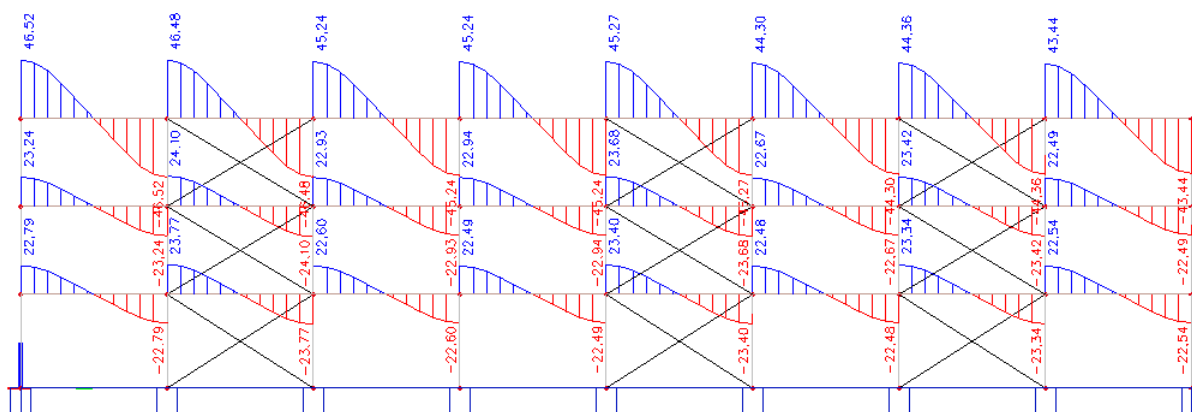

Slika 21: Ovojnica prečnih sil  $V_{Ed}$  [kN] najbolj obremenjenega okvirja

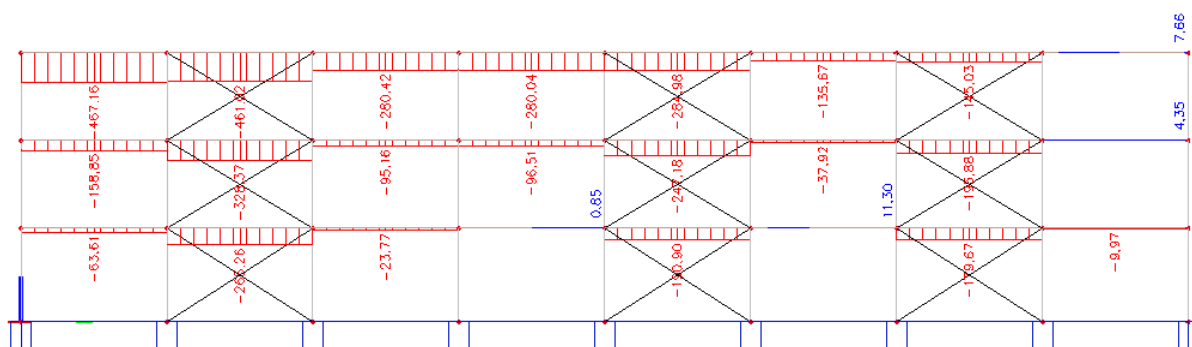

Slika 22: Ovojnica osnih sil  $N_{Ed}$  [kN] najbolj obremenjenega okvirja

### Dimenzioniranje prečk

Dimenzioniranje in kontroliranje prečk sem izvedel s programom SCIA Engineer. Vsi rezultati in kontrole so v prilogi A.

## 5.2 Mejno stanje uporabnosti

Pri mejnem stanju nosilnosti je potrebno preveriti vse pomike, ki lahko bistveno vplivajo na bivalno okolje in življenjsko dobo konstrukcije.

Pri MSU je upoštevana začetna globalna geometrijska nepopolnost.

### 5.2.1 Momentni okvir

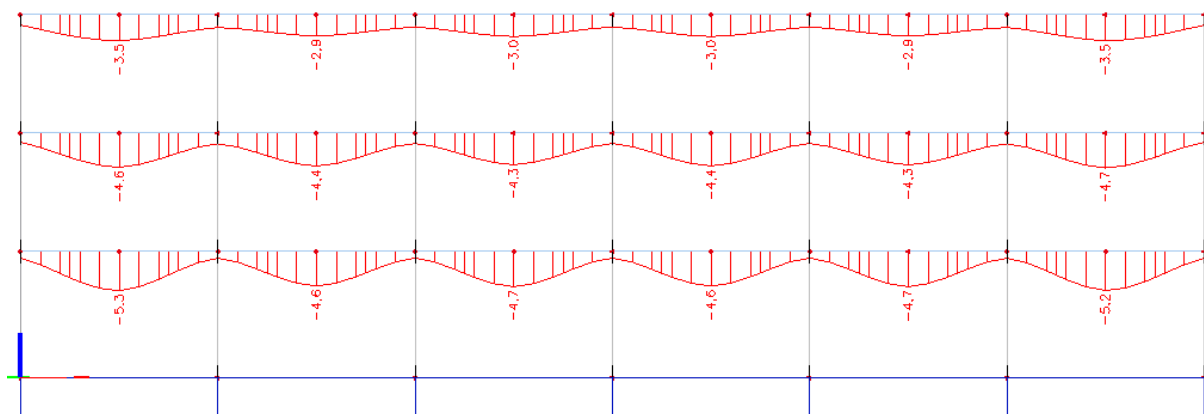

Slika 23: Ovojnica vertikalnih pomikov  $u_z$  [mm] za MSU

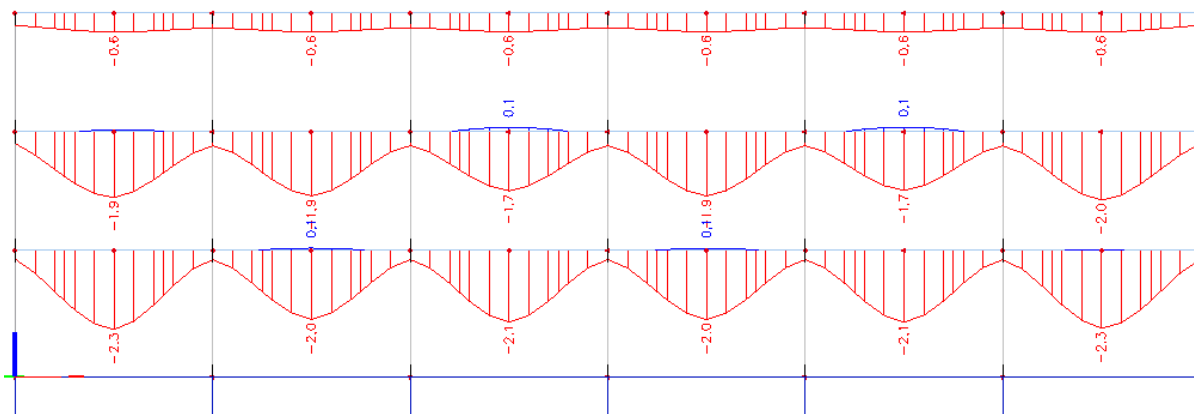

Slika 24: Ovojnica vertikalnih pomikov  $u_z$  [mm] zaradi koristne obtežbe

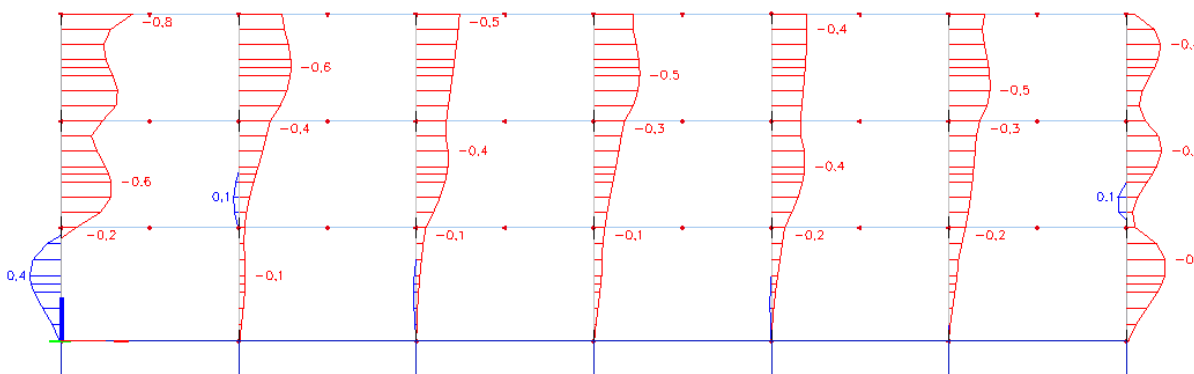

Slika 25: Ovojnica horizontalnih pomikov  $u_x$  [mm] za MSU

**Vertikalni pomiki**

$$\delta_{max} = 0,53cm \leq \frac{L}{250} = \frac{500cm}{250} = 2,0cm$$

$$\delta_Q = 0,23cm \leq \frac{L}{350} = \frac{500cm}{350} = 1,43cm$$

kjer so:

$\delta_{max}$ .....vertikalni pomik pri MSU

$\delta_Q$ .....vertikalni pomik zaradi koristne obtežbe

L.....razpon med stebri

### Horizontalni pomiki

- Posamezna etaža

$$\delta_1 = 0,06cm \leq \frac{h_1}{300} = \frac{320cm}{300} = 1,06cm$$

$$\delta_2 = 0,04cm \leq \frac{h_2}{300} = \frac{300cm}{300} = 1,0cm$$

$$\delta_3 = 0,02cm \leq \frac{h_3}{300} = \frac{300cm}{300} = 1,0cm$$

- Celotna stavba

$$\delta = 0,12cm \leq \frac{H}{500} = \frac{920cm}{500} = 1,84cm$$

kjer so:

$\delta_{1,2,3}$ .....horizontalni pomiki posamezne etaže

$\delta$ .....horizontalni pomik celotnega objekta

H.....višina objekta

### 5.2.2 Okvir z centričnim povezjem

Okvir z centričnim povezjem prevzame samo horizontalne pomike, zato preverim pomike samo v horizontalni smeri.

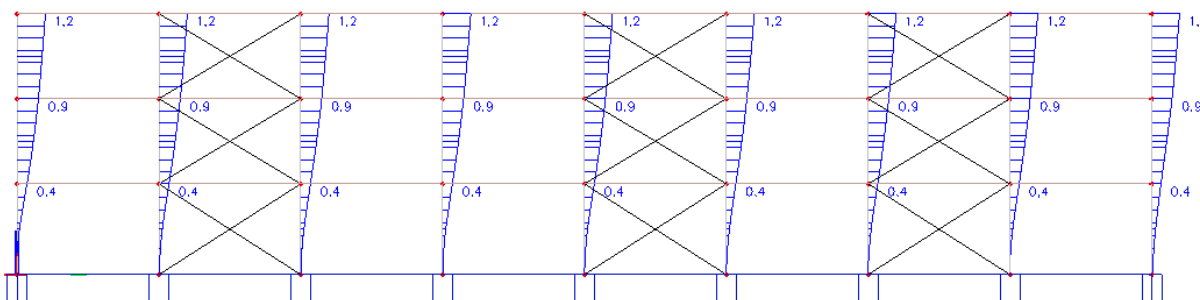

Slika 26: Ovojnica horizontalnih pomikov  $u_y$  [mm] za MSU

## Horizontalni pomiki

- Posamezna etaža

$$\delta_1 = 0,04cm \leq \frac{h_1}{300} = \frac{320cm}{300} = 1,06cm$$

$$\delta_2 = 0,05cm \leq \frac{h_2}{300} = \frac{300cm}{300} = 1,0cm$$

$$\delta_3 = 0,03cm \leq \frac{h_3}{300} = \frac{300cm}{300} = 1,0cm$$

- Celotna stavba

$$\delta = 0,12cm \leq \frac{H}{500} = \frac{920cm}{500} = 1,84cm$$

## 5.3 Kontrola medetažnih pomikov za potresno obtežbo

### 5.3.1 Momentni okvir

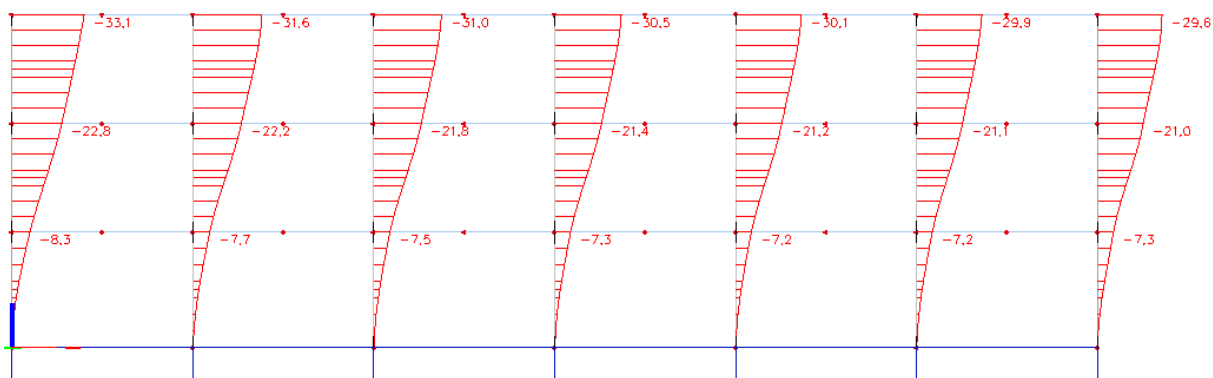

Slika 27: Ovojnica horizontalnih pomikov  $u_x$  [mm] za potresno obtežno kombinacijo

$$d_{s1} = 0,83cm \rightarrow d_{r1} = d_{s1} * q_d = 0,83cm * 3,25 = 2,70cm$$

$$d_{s2} = 1,45cm \rightarrow d_{r2} = d_{s2} * q_d = 1,45cm * 3,25 = 4,70cm$$

$$d_{s3} = 1,03cm \rightarrow d_{r3} = d_{s3} * q_d = 1,03cm * 3,25 = 3,35cm$$

$$d_{r1} * v = 2,70cm * 0,5 = \boxed{1,35cm} \leq 0,01 * h_1 = 0,01 * 320cm = \boxed{3,2cm}$$

$$d_{r2} * v = 4,70cm * 0,5 = \boxed{2,35cm} \leq 0,01 * h_2 = 0,01 * 300cm = \boxed{3,0cm}$$

$$d_{r3} * v = 3,35cm * 0,5 = \boxed{1,67cm} \leq 0,01 * h_3 = 0,01 * 300cm = \boxed{3,0cm}$$

kjer so:

$d_{s1,2,3}$ .....horizontalni pomiki posameznih etaž

$q_d$ .....faktor obnašanja za pomike

$d_{r1,2,3}$ .....projektni etažni pomik

$v$ .....redukcijski faktor, ki upošteva manjšo povratno dobo potresa

$h_{1,2,3}$ .....višina posamezne etaže

### 5.3.2 Okvir z centričnim povezjem

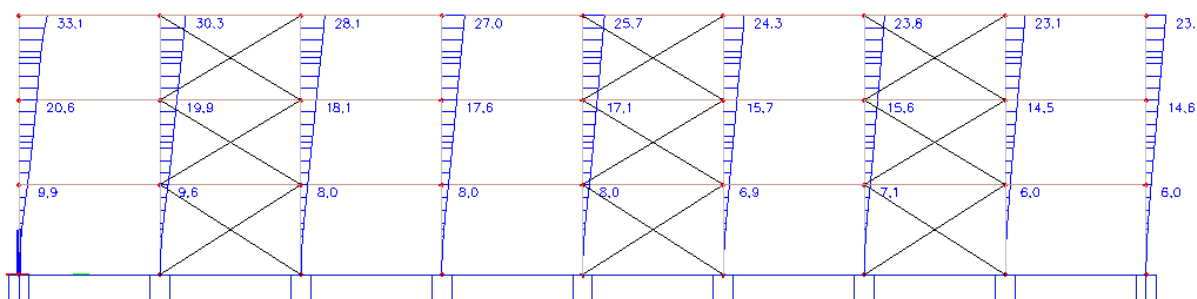

Slika 28: Ovojnica horizontalnih pomikov  $u_x$  [mm] za potresno obtežno kombinacijo

$$d_{s1} = 0,99cm \rightarrow d_{r1} = d_{s1} * q_d = 0,99cm * 4 = 3,96cm$$

$$d_{s2} = 1,07cm \rightarrow d_{r2} = d_{s2} * q_d = 1,07cm * 4 = 4,28cm$$

$$d_{s3} = 1,25cm \rightarrow d_{r3} = d_{s3} * q_d = 1,25cm * 4 = 5,0cm$$

$$d_{r1} * v = 3,96cm * 0,5 = \boxed{1,98cm} \leq 0,01 * h_1 = 0,01 * 320cm = \boxed{3,2cm}$$

$$d_{r2} * v = 4,28cm * 0,5 = \boxed{2,14cm} \leq 0,01 * h_2 = 0,01 * 300cm = \boxed{3,0cm}$$

$$d_{r3} * v = 5,0cm * 0,5 = \boxed{2,5cm} \leq 0,01 * h_3 = 0,01 * 300cm = \boxed{3,0cm}$$

### 5.4 Posebna pravila za protipotresno gradnjo jeklenih konstrukcij

Pri načinu projektiranja s sipanjem energije je v območju sipanja potrebno zagotoviti ustrezno globalno in lokalno duktilnost, ostale konstrukcije, ki ostanejo v elastičnem režimu





### 5.4.1.1 Dimenzioniranje nosilcev

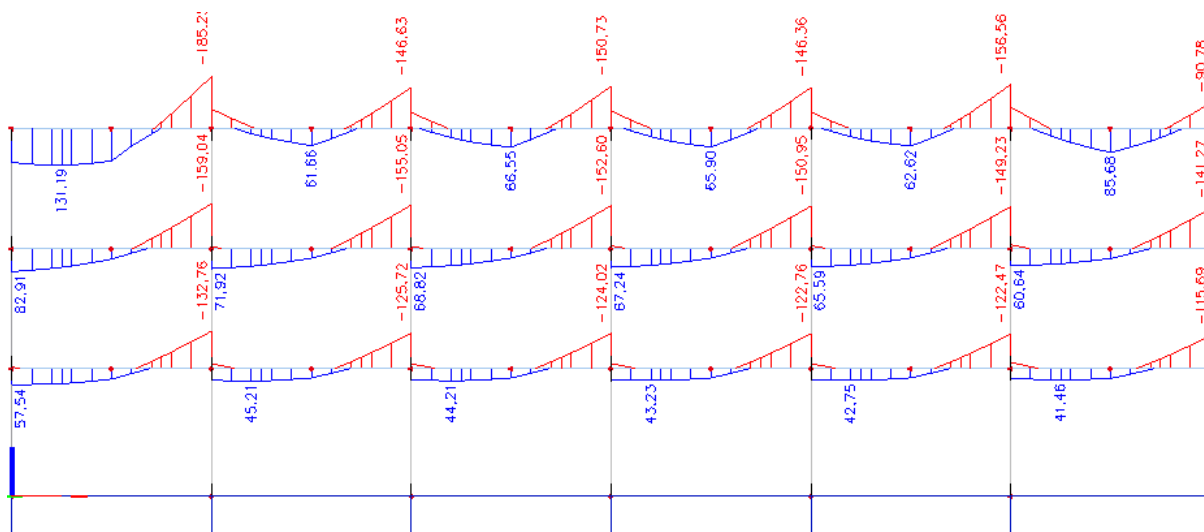

Slika 31: Ovojnica notranjih sil  $M_{Ed}$  [kNm] zaradi potresne obtežne kombinacije

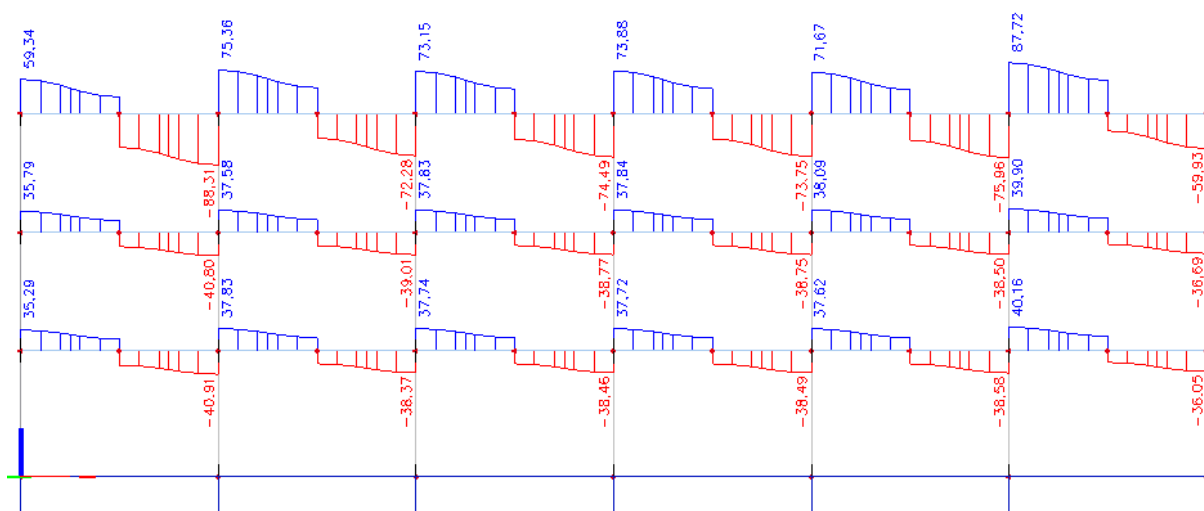

Slika 32: Ovojnica notranjih sil  $V_{Ed}$  [kN] zaradi gravitacijske obtežbe

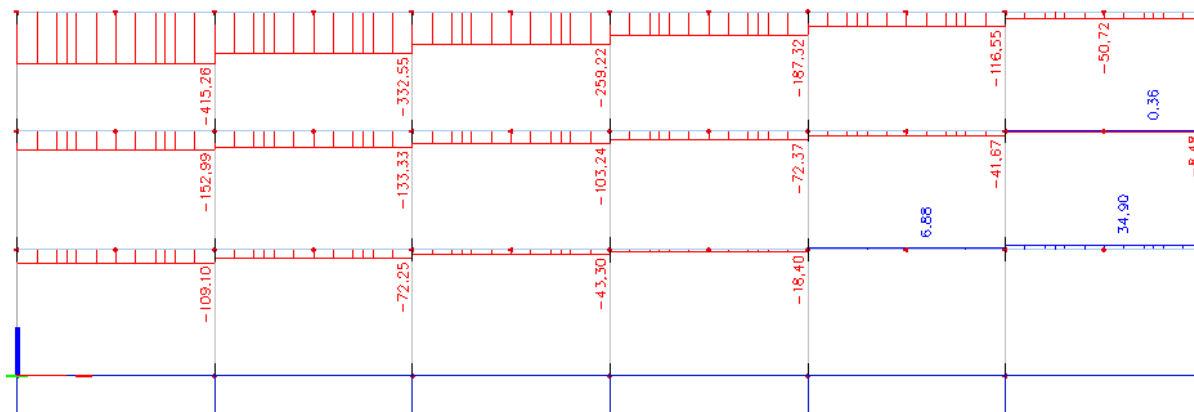

Slika 33: Ovojnica notranjih sil  $N_{Ed}$  [kN] zaradi potresne obtežne kombinacije

### Nosilci (IPE 330)

- kontrola upogibne nosilnosti

$$\frac{M_{Ed}}{M_{pl,Rd}} = \frac{141,6 \text{ kNm}}{188,9 \text{ kNm}} = 0,75 \leq 1,0$$

$$M_{pl,Rd} = W_{pl,y} * \frac{f_y}{\gamma_{M0}} = 804 \text{ cm}^3 * \frac{23,5 \frac{\text{kN}}{\text{cm}^2}}{1,0} = 188,9 \text{ kNm}$$

- kontrola osne sile

$$\frac{N_{Ed}}{N_{pl,Rd}} = \frac{109,1 \text{ kN}}{1471,1 \text{ kN}} = 0,07 \leq 0,15$$

$$N_{pl,Rd} = A * \frac{f_y}{\gamma_{M0}} = 62,6 \text{ cm}^2 * \frac{23,5 \frac{\text{kN}}{\text{cm}^2}}{1,0} = 1471,1 \text{ kN}$$

- kontrola prečne sile

$$\frac{V_{Ed}}{V_{pl,Rd}} = \frac{116,6 \text{ kN}}{349,2 \text{ kN}} = 0,33 \leq 0,5$$

$$V_{pl,Rd} = A_v * \frac{f_y}{\sqrt{3} * \gamma_{M0}} = 25,74 \text{ cm}^2 * \frac{23,5 \frac{\text{kN}}{\text{cm}^2}}{\sqrt{3} * 1,0} = 349,2 \text{ kN}$$

$$A_v = 1,04 * h * t_w = 1,04 * 33 \text{ cm} * 0,75 \text{ cm} = 25,74 \text{ cm}^2$$

$$V_{Ed} = V_{Ed,G} + V_{Ed,M} = 41kN + 75,6kN = 116,6kN$$

$$V_{Ed,G} = 41kN$$

$$V_{Ed,M} = \frac{2 * M_{pl,Rd}}{L} = \frac{2 * 188,9kNm}{5m} = 75,6kN$$

### Nosilci (IPE 360)

- kontrola upogibne nosilnosti

$$\frac{M_{Ed}}{M_{pl,Rd}} = \frac{165,6kNm}{239,5kNm} = 0,69 \leq 1,0$$

$$M_{pl,Rd} = W_{pl,y} * \frac{f_y}{\gamma_{M0}} = 1019cm^3 * \frac{23,5 \frac{kN}{cm^2}}{1,0} = 239,5kNm$$

- kontrola osne sile

$$\frac{N_{Ed}}{N_{pl,Rd}} = \frac{153kN}{1708,5kN} = 0,09 \leq 0,15$$

$$N_{pl,Rd} = A * \frac{f_y}{\gamma_{M0}} = 72,7cm^2 * \frac{23,5 \frac{kN}{cm^2}}{1,0} = 1708,5kN$$

- kontrola prečne sile

$$\frac{V_{Ed}}{V_{pl,Rd}} = \frac{136,6kN}{406,4kN} = 0,34 \leq 0,5$$

$$V_{pl,Rd} = A_v * \frac{f_y}{\sqrt{3} * \gamma_{M0}} = 29,95cm^2 * \frac{23,5 \frac{kN}{cm^2}}{\sqrt{3} * 1,0} = 406,4kN$$

$$A_v = 1,04 * h * t_w = 1,04 * 36cm * 0,8cm = 29,95cm^2$$

$$V_{Ed} = V_{Ed,G} + V_{Ed,M} = 40,8kN + 95,8kN = 136,6kN$$

$$V_{Ed,G} = 40,8kN$$

$$V_{Ed,M} = \frac{2 * M_{pl,Rd}}{L} = \frac{2 * 239,5kNm}{5m} = 95,8kN$$

### Nosilci (IPE 500)

- kontrola upogibne nosilnosti

$$\frac{M_{Ed}}{M_{pl,Rd}} = \frac{185,3kNm}{515,6kNm} = 0,36 \leq 1,0$$

$$M_{pl,Rd} = W_{pl,y} * \frac{f_y}{\gamma_{M0}} = 2194cm^3 * \frac{23,5 \frac{kN}{cm^2}}{1,0} = 515,6kNm$$

- kontrola osne sile

$$\frac{N_{Ed}}{N_{pl,Rd}} = \frac{415,3kN}{2726kN} = 0,14 \leq 0,15$$

$$N_{pl,Rd} = A * \frac{f_y}{\gamma_{M0}} = 116cm^2 * \frac{23,5 \frac{kN}{cm^2}}{1,0} = 2726kN$$

- kontrola prečne sile

$$\frac{V_{Ed}}{V_{pl,Rd}} = \frac{294,5kN}{1246,4kN} = 0,24 \leq 0,5$$

$$V_{pl,Rd} = A_v * \frac{f_y}{\sqrt{3} * \gamma_{M0}} = 53,04cm^2 * \frac{23,5 \frac{kN}{cm^2}}{\sqrt{3} * 1,0} = 1246,4kN$$

$$A_v = 1,04 * h * t_w = 1,04 * 50cm * 1,02cm = 53,04cm^2$$

$$V_{Ed} = V_{Ed,G} + V_{Ed,M} = 88,3kN + 206,2kN = 294,5kN$$

$$V_{Ed,G} = 88,3kN$$

$$V_{Ed,M} = \frac{2 * M_{pl,Rd}}{L} = \frac{2 * 515,6kNm}{5m} = 206,2kN$$

### 5.4.1.2 Dimenzioniranje stebrov

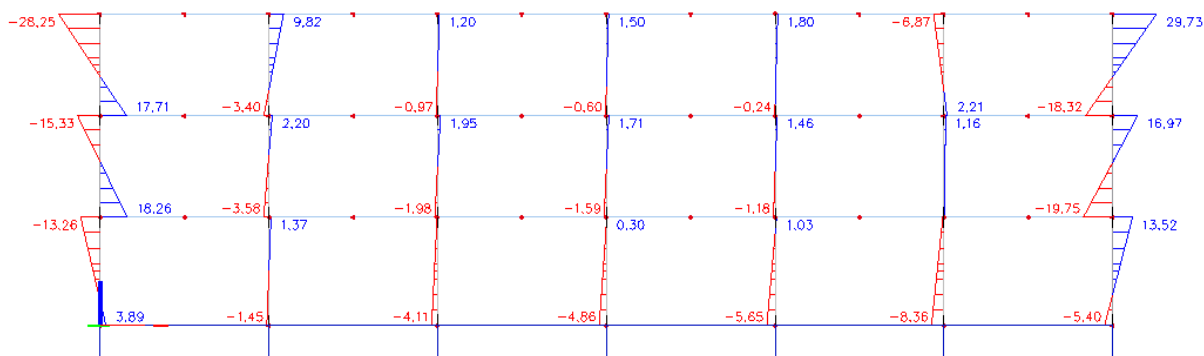

Slika 34: Ovojnica notranjih sil  $M_{Ed}$  [kNm] zaradi gravitacijske obtežbe

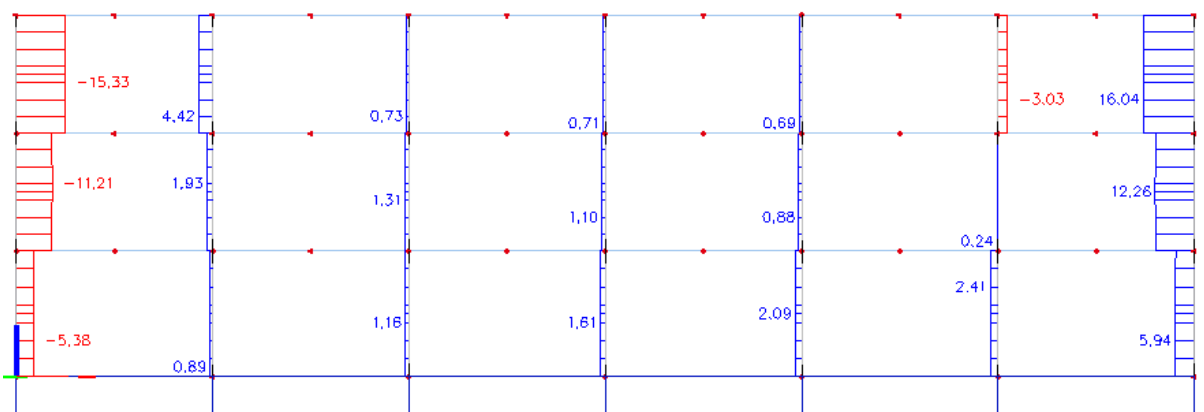

Slika 35: Ovojnica notranjih sil  $V_{Ed}$  [kN] zaradi gravitacijske obtežbe

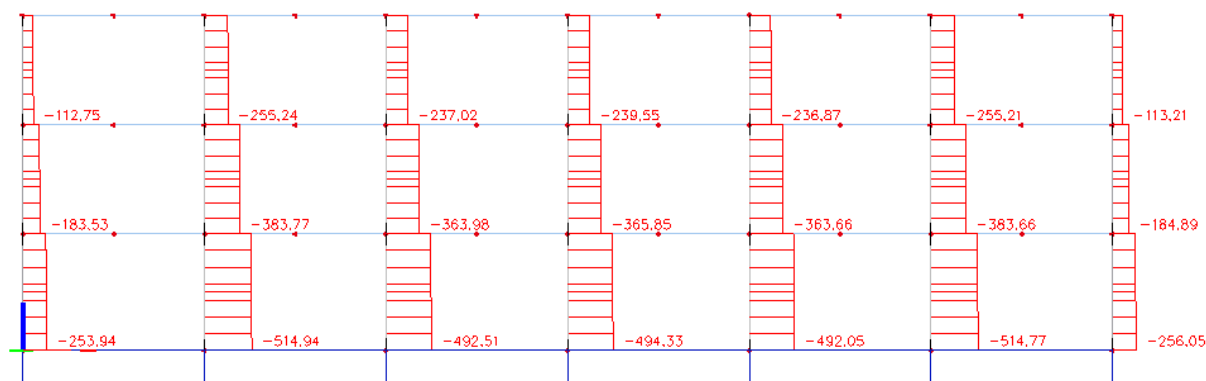

Slika 36: Ovojnica notranjih sil  $N_{Ed}$  [kN] zaradi gravitacijske obtežbe

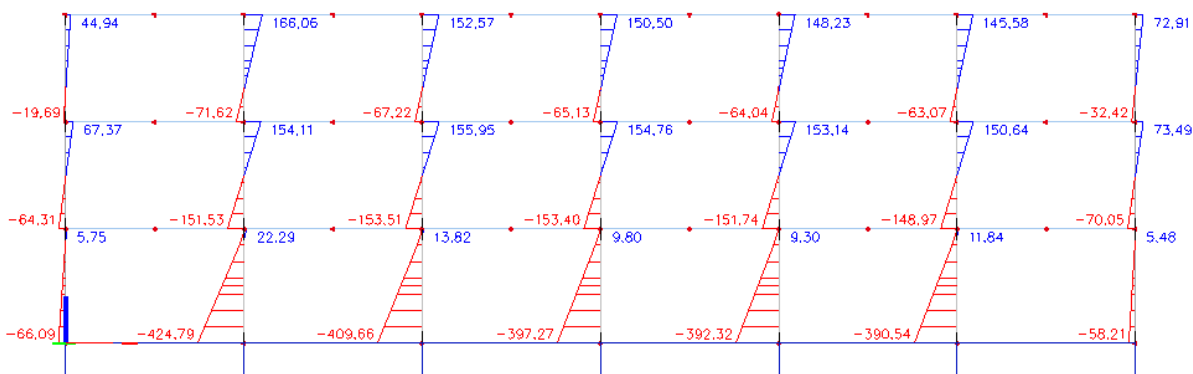

Slika 37: Ovojnica notranjih sil  $M_{Ed}$  [kNm] zaradi potresne obtežbe

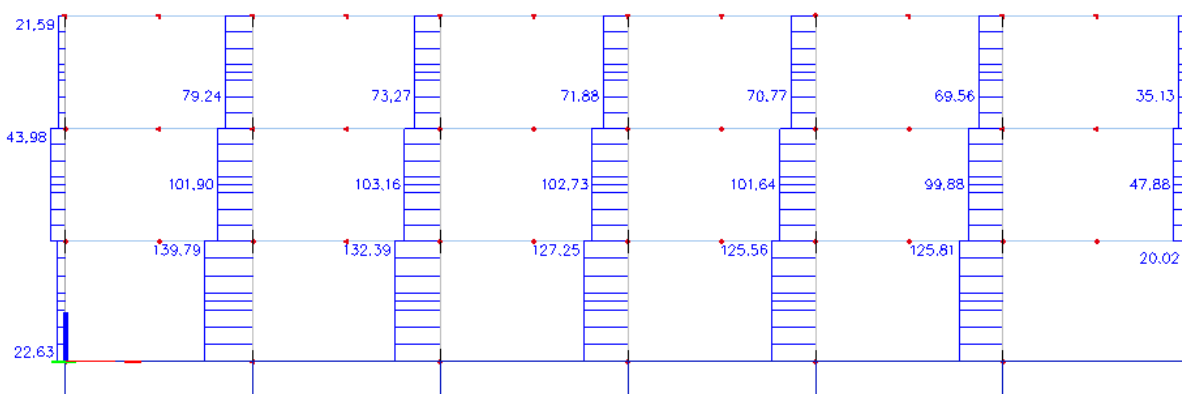

Slika 38: Ovojnica notranjih sil  $V_{Ed}$  [kN] zaradi potresne obtežbe

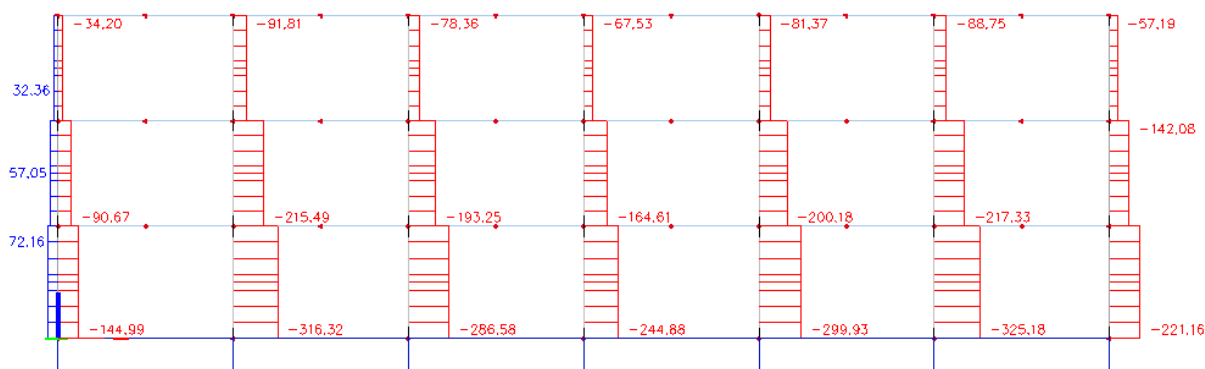

Slika 39: Ovojnica notranjih sil  $N_{Ed}$  [kN] zaradi potresne obtežbe

### Stebri (HEB 500)

Stebre izven območja sipanja energije je potrebno zavarovati pred preobremenitvami, ki bi lahko nastopile zaradi polne plastifikacije elementov, ki sipajo energijo. Pri tem je potrebno upoštevati ocenjeno dejansko plastično nosilnost. To dosežemo z upoštevanjem faktorja

dotatne nosilnosti  $\gamma_{ov}$  in faktorja dodatne nosilnosti prečnega prereza  $\Omega$ . Projektne vrednosti notranjih sil se v teh elementih izračunajo na naslednji način:

$$N_{Ed} = N_{Ed,G} + 1,1 * \gamma_{ov} * \Omega * N_{Ed,E}$$

$$M_{Ed} = M_{Ed,G} + 1,1 * \gamma_{ov} * \Omega * M_{Ed,E}$$

$$V_{Ed} = V_{Ed,G} + 1,1 * \gamma_{ov} * \Omega * V_{Ed,E}$$

- faktor dodatne nosilnosti prereza

$$\Omega_i = \frac{M_{pl,Rd}}{M(M_G + M_E)}$$

$$\Omega_1 = \frac{M_{pl,Rd}}{M_{Ed}^1} = \frac{188,9kNm}{141,6kNm} = 1,32$$

$$\Omega_2 = \frac{M_{pl,Rd}}{M_{Ed}^2} = \frac{239,5kNm}{165,6kNm} = 1,45$$

$$\Omega_3 = \frac{M_{pl,Rd}}{M_{Ed}^3} = \frac{515,6kNm}{185,3kNm} = 2,78$$

$$\Omega = \Omega_{min} = 1,32$$

$$\gamma_{ov} = 1,25$$

- prerez stebra ob vpetju

$$N_{Ed} = N_{Ed,G} + 1,1 * \gamma_{ov} * \Omega * N_{Ed,E} = 514,9kN + 1,1 * 1,25 * 1,32 * 384,9kN \\ = 1208,7kN$$

$$M_{Ed} = M_{Ed,G} + 1,1 * \gamma_{ov} * \Omega * M_{Ed,E} = 8,4kNm + 1,1 * 1,25 * 1,32 * 484,4kNm \\ = 879,6kNm$$

$$V_{Ed} = V_{Ed,G} + 1,1 * \gamma_{ov} * \Omega * V_{Ed,E} = 2,4kN + 1,1 * 1,25 * 1,32 * 162,3kN = 300,2kN$$

- kontrola nosilnosti stebra

$$\frac{N_{Ed}}{N_{pl,Rd}} + \frac{M_{Ed}}{M_{pl,Rd}} = \frac{1208,7kN}{5616,5kN} + \frac{879,6kNm}{1131,5kNm} = 0,99 \leq 1,0$$



$$N_{pl,Rd} = A * \frac{f_y}{\gamma_{M0}} = 239 \text{ cm}^2 * \frac{23,5 \frac{\text{kN}}{\text{cm}^2}}{1,0} = 5616,5 \text{ kN}$$

$$M_{pl,Rd} = W_{pl,y} * \frac{f_y}{\gamma_{M0}} = 4815 \text{ cm}^3 * \frac{23,5 \frac{\text{kN}}{\text{cm}^2}}{1,0} = 1131,5 \text{ kNm}$$

- kontrola strižne nosilnosti

$$\frac{V_{Ed}}{V_{pl,Rd}} = \frac{300,2 \text{ kN}}{1023,0 \text{ kN}} = 0,30 \leq 0,5$$

$$V_{pl,Rd} = 1,04 * h * t_w * \frac{f_y}{\sqrt{3} * \gamma_{M0}} = 1,04 * 50 \text{ cm} * 1,45 \text{ cm} * \frac{23,5 \frac{\text{kN}}{\text{cm}^2}}{\sqrt{3} * 1,0} = 1023,0 \text{ kN}$$

- strižna nosilnost panela stebra

Strižna nosilnost panela stojine stebra v območju spoja prečka – steber mora zadoščati pogoju:

$$\frac{V_{wp,Ed}}{V_{wp,Rd}} = \frac{400,2 \text{ kN}}{920,7 \text{ kN}} = 0,44 \leq 1,0$$

$$V_{wp,Ed} = \frac{M_{pl,Rd}}{h_T} = \frac{18890 \text{ kNcm}}{47,2 \text{ cm}} = 400,2 \text{ kN}$$

$$V_{wp,Rd} = \frac{\eta * d * t_w * f_y}{\sqrt{3} * \gamma_{M0}} = \frac{1,2 * 39 \text{ cm} * 1,45 \text{ cm} * 23,5 \frac{\text{kN}}{\text{cm}^2}}{\sqrt{3} * 1,0} = 920,7 \text{ kN}$$

### **Stebri (HEA 340)**

- prerez stebra ob vpetju

$$N_{Ed} = N_{Ed,G} + 1,1 * \gamma_{ov} * \Omega * N_{Ed,E} = 383,8 \text{ kN} + 1,1 * 1,25 * 1,32 * 236,6 \text{ kN} = 813,2 \text{ kN}$$

$$\begin{aligned} M_{Ed} &= M_{Ed,G} + 1,1 * \gamma_{ov} * \Omega * M_{Ed,E} = 16,2 \text{ kNm} + 1,1 * 1,25 * 1,32 * 169,5 \text{ kNm} \\ &= 320,2 \text{ kNm} \end{aligned}$$

$$V_{Ed} = V_{Ed,G} + 1,1 * \gamma_{ov} * \Omega * V_{Ed,E} = 8,4 \text{ kN} + 1,1 * 1,25 * 1,32 * 110,1 \text{ kN} = 208,2 \text{ kN}$$

- kontrola nosilnosti stebra

$$\frac{N_{Ed}}{N_{pl,Rd}} + \frac{M_{Ed}}{M_{pl,Rd}} = \frac{813,2kN}{3125,5kN} + \frac{320,2kNm}{434,8kNm} = 0,99 \leq 1,0$$

$$N_{pl,Rd} = A * \frac{f_y}{\gamma_{M0}} = 133cm^2 * \frac{23,5 \frac{kN}{cm^2}}{1,0} = 3125,5kN$$

$$M_{pl,Rd} = W_{pl,y} * \frac{f_y}{\gamma_{M0}} = 1850cm^3 * \frac{23,5 \frac{kN}{cm^2}}{1,0} = 434,8kNm$$

- kontrola strižne nosilnosti

$$\frac{V_{Ed}}{V_{pl,Rd}} = \frac{208,2kN}{442,4kN} = 0,47 \leq 0,5$$

$$V_{pl,Rd} = 1,04 * h * t_w * \frac{f_y}{\sqrt{3} * \gamma_{M0}} = 1,04 * 33cm * 0,95cm * \frac{23,5 \frac{kN}{cm^2}}{\sqrt{3} * 1,0} = 442,4kN$$

- strižna nosilnost panela stebra

Strižna nosilnost panela stojine stebra v območju spoja prečka – steber mora zadoščati pogoju:

$$\frac{V_{wp,Ed}}{V_{wp,Rd}} = \frac{1240kN}{375,9kN} = 3,3 \leq 1,0$$

$$V_{wp,Ed} = \frac{M_{pl,Rd}}{h_T} = \frac{51559kNcm}{41,58cm} = 1240kN$$

$$V_{wp,Rd} = \frac{\eta * d * t_w * f_y}{\sqrt{3} * \gamma_{M0}} = \frac{1,2 * 24,3cm * 0,95cm * 23,5 \frac{kN}{cm^2}}{\sqrt{3} * 1,0} = 375,9kN$$

Stojino stebra je potrebno ojačati:

$$t_w = \frac{V_{wp,Ed} * \sqrt{3} * \gamma_{M0}}{\eta * d * f_y} = \frac{1240kN * \sqrt{3} * 1,0}{1,2 * 24,3cm * 23,5 \frac{kN}{cm^2}} = 3,13cm$$

Izberem pločevino 2x20mm

### 5.4.2 Okvir z centričnim povezjem

Okvirje s centričnim povezjem je treba projektirati, tako da plastifikacija nateznih diagonal nastopi pred poružitvijo spojev in pred plastifikacijo ter nestabilnostjo nosilcev in stebrov.

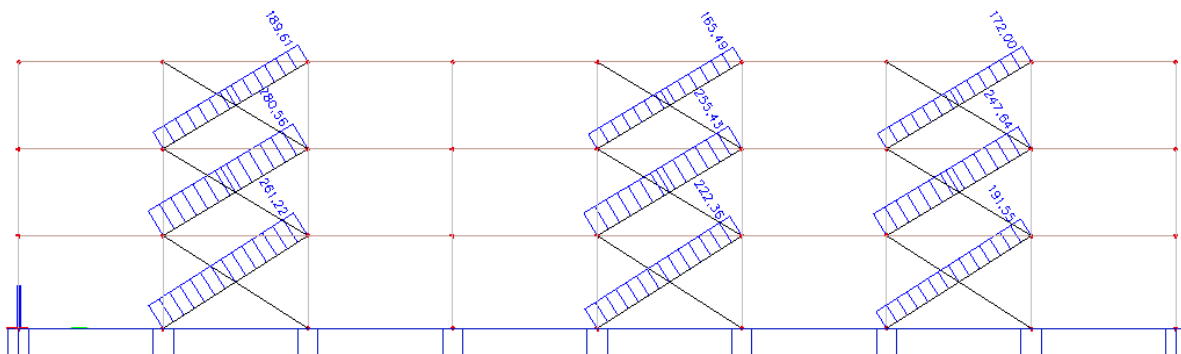

Slika 40: Ovojnica notranjih sil  $N_{Ed}$  [kN] za potresno obtežno kombinacijo

- relativna vitkost

V okvirjih s centričnimi X povezji je relativna vitkost  $\bar{\lambda}$  omejena z:

$$1,3 \leq \bar{\lambda} \leq 2,0$$

#### Kvadratna cev (VHP60/60x6,0mm) v prvi etaži

$$\bar{\lambda} = \frac{L_u}{i * \lambda_1} = \frac{593,6cm}{2,16cm * 93,9} = 1,46$$

$$\varepsilon = \sqrt{\frac{235}{f_y}} = \sqrt{\frac{235}{235}} = 1,0$$

$$\lambda_1 = 93,9 * \varepsilon = 93,9 * 1,0 = 93,9$$

$$i = \sqrt{\frac{I}{A}} = \sqrt{\frac{56,1cm^4}{12cm^2}} = 2,16cm$$

#### Kvadratna cev (VHP60/60x6,0mm) v drugi etaži

$$\bar{\lambda} = \frac{L_u}{i * \lambda_1} = \frac{583,1cm}{2,16cm * 93,9} = 1,44$$

**Kvadratna cev (VHP50/50x5,0mm) v tretji etaži**

$$\bar{\lambda} = \frac{L_u}{i * \lambda_1} = \frac{\frac{583,1cm}{2}}{1,79cm * 93,9} = 1,73$$

$$i = \sqrt{\frac{I}{A}} = \sqrt{\frac{27,0cm^4}{8,4cm^2}} = 1,79cm$$

- faktor dodatne nosilnosti prereza

Pogoj je, da se  $\Omega_i$  posamezne etaže ne sme razlikovati za več kot 25%.

**Kvadratna cev (VHP60/60x6,0mm) v prvi etaži**

$$N_{pl,Rd} = A * \frac{f_y}{\gamma_{M0}} = 12,0 * \frac{23,5 \frac{kN}{cm^2}}{1,0} = 282,0kN$$

$$\Omega_1 = \frac{N_{pl,Rd}}{N_{Ed}^1} = \frac{282,0kN}{261,2kN} = 1,08$$

**Kvadratna cev (VHP60/60x6,0mm) v prvi etaži**

$$\Omega_2 = \frac{N_{pl,Rd}}{N_{Ed}^2} = \frac{282,0kN}{280,6kN} = 1,01$$

**Kvadratna cev (VHP50/50x5,0mm) v tretji etaži**

$$N_{pl,Rd} = A * \frac{f_y}{\gamma_{M0}} = 8,4 * \frac{23,5 \frac{kN}{cm^2}}{1,0} = 197,4kN$$

$$\Omega_3 = \frac{N_{pl,Rd}}{N_{Ed}^3} = \frac{197,4kN}{189,6kN} = 1,04$$

$$\Omega_{max} = 1,08 \leq 1,25 * \Omega_{min} = 1,25 * 1,01 = 1,26$$

## 6 MEDETAŽNA KONSTRUKCIJA

### 6.1 Sovprežna plošča

#### Material

- beton C25/30
- pločevina HI-Bond 55;  $t = 0,8\text{mm}$ ;  $f_y = 250\text{MPa}$
- armatura S500
- strižni čepi NELSON čepi  $\Phi 19$ ,  $f_u = 45\text{kN/cm}^2$ ;  $h_{sc} = 10\text{cm}$

#### Geometrija

- skupna debelina sovprežne plošče  $h = 14\text{cm}$
- efektivna debelina sovprežne plošče  $d_p = 14 - 5,5/2 = 11,25\text{cm}$
- razmak med podpornimi nosilci  $L = 2,5\text{m}$
- razmak med začasnimi podporami  $L_{zp} = L/3 = 166,7\text{cm}$
- širina podpor (končne inčasne)  $b \geq 100\text{mm}$

#### Obtežba

- lastna  $g_1 = 2,91\text{kN/m}^2$
- stalna  $g_s = 1,70\text{kN/m}^2$
- koristna  $q = 4,25\text{kN/m}^2$

#### 6.1.1 Montažno stanje

- razmak med začasnimi podporami  $L_{zp} = L/2 = 125\text{cm}$

$$L_{zp}^{max} = \min(230\text{cm}, 261\text{cm}) = 230\text{cm} > L_{zp} = 125\text{cm}$$

#### 6.1.2 Končno stanje

#### Mejno stanje nosilnosti

Po metodi delne strižne vezi upoštevam metodo B4.

$$p_{Sd,MSN} = 1,35 * g_1 + 1,5 * q = 1,35 * 1,7 \frac{\text{kN}}{\text{m}^2} + 1,5 * 4,25 \frac{\text{kN}}{\text{m}^2} = 8,67 \frac{\text{kN}}{\text{m}^2}$$

$$L_{max} = 395\text{cm} > L = 250\text{cm}$$

**Mejno stanje uporabnosti**

Po metodi delne strižne vezi upoštevam metodo B4.

$$p_{sd,MSU} = 1,0 * g_1 + 1,0 * q = 1,0 * 1,7 \frac{kN}{m^2} + 1,0 * 4,25 \frac{kN}{m^2} = 5,95 \frac{kN}{m^2}$$

$$L_{max} = 464cm > L = 250cm$$

**6.1.3 Potrebna armatura****Negativna armatura nad podporami**

Ker kontinuirani sistem sovprežne plošče obravnavamo kot niz prostoležečih plošč, je potrebno zagotoviti negativno armaturo nad podpornimi nosilci. Negativno armaturo namestimo na razdalji 0,25L na obe strani podpore.

$$A_{neg} = 0,004 * 100cm * (h - h_p) = 0,004 * 100cm * (14cm - 5,5cm) = 3,4cm^2/m$$

Izberem armaturne palice  $\Phi 10/20cm$ .

**Armaturo za rano obtežbo**

Armaturo za rano obtežbo se postavi na pločevino in je potrebna v primeru koncentriranih sil, linijske obtežbe oz. porazdeljene obtežbe, ki deluje po delu površine plošče.

Ker v mojem primeru obtežba deluje po celotni površini plošče, te armature ne potrebujemo.

Na podlagi dobre prakse je priporočljivo, da se tovrstna armatura vseeno vgradi (predelne stene, lažja koncentrirana oprema, koristna obtežba lahko deluje le po delu plošče).

$$A_{raznos} = 0,002 * 100cm * (h - h_p) = 0,002 * 100cm * (14cm - 5,5cm) = 1,7cm^2/m$$

Izberem armaturno mrežo Q257

## 6.2 Sovprežni nosilec IPE 270



Slika 41: Zasnova sovprežnega nosilca

- izbira jeklenih profilov:

$$h_a \approx \frac{L}{25} = \frac{500\text{cm}}{25} = 20\text{cm}$$

Izberem IPE 270.

### 6.2.1 Material

- beton C25/30
- jeklo S235
- armatura S500

### 6.2.2 Obtežba

- lastna
  - jekleni nosilec  $g_a = 0,35\text{kN/m}$
  - betonska plošča  $g_{c1} = 2,91 \frac{\text{kN}}{\text{m}^2} * 2,5\text{m} = 7,3 \frac{\text{kN}}{\text{m}}$  (strjen)
  - $g_{c2} = 3,03 \frac{\text{kN}}{\text{m}^2} * 2,5\text{m} = 7,6 \frac{\text{kN}}{\text{m}}$  (svež)
  - opaž (ocena)  $g_{op} = 0,4 \frac{\text{kN}}{\text{m}^2} * 2,5\text{m} = 1,0 \frac{\text{kN}}{\text{m}}$
  - tlaki  $g_{ost} = 1,7 \frac{\text{kN}}{\text{m}^2} * 2,5\text{m} = 4,25 \frac{\text{kN}}{\text{m}}$
- koristna
  - med betoniranjem  $q_m = 0,75 \frac{\text{kN}}{\text{m}^2} * 2,5\text{m} = 1,9 \frac{\text{kN}}{\text{m}}$
  - končno stanje  $q_k = 4,25 \frac{\text{kN}}{\text{m}^2} * 2,5\text{m} = 10,6 \frac{\text{kN}}{\text{m}}$
- delavci, oprema  $q_{ost} = 0,75 \frac{\text{kN}}{\text{m}^2} * 2,5\text{m} = 1,9 \frac{\text{kN}}{\text{m}}$

### 6.2.3 Montažno stanje

- obremenitev

$$\begin{aligned}
 q_{Ed} &= 1,35 * g_a + 1,35 * g_{c2} + 1,35 * q_{op} + 1,5 * q_m \\
 &= 1,35 * 0,35 \frac{kN}{m} + 1,35 * 7,6 \frac{kN}{m} + 1,35 * 1,0 \frac{kN}{m} + 1,5 * 1,9 \frac{kN}{m} \\
 &= 14,6 kN/m
 \end{aligned}$$

$$M_{Ed} = \frac{q_{Ed} * L^2}{8} = \frac{14,6 \frac{kN}{m} * (5m)^2}{8} = 45,6 kNm$$

$$V_{Ed} = \frac{q_{Ed} * L}{2} = \frac{14,6 \frac{kN}{m} * 5m}{2} = 36,5 kN$$

- kontrola upogibne nosilnosti

$$M_{Ed} = 45,6 kNm \leq M_{el,y} = W_y * \frac{f_y}{\gamma_{M0}} = 429 cm^3 * \frac{23,5 \frac{kN}{cm^2}}{1,0} = 100,8 kNm$$

- kontrola strižne nosilnosti

$$V_{Ed} = 36,5 kN \leq V_{pl,Rd} = A_v * \frac{f_y}{\sqrt{3} * \gamma_{M0}} = 18,5 cm^2 * \frac{23,5 \frac{kN}{m^2}}{\sqrt{3} * 1,0} = 251,4 kN$$

$$A_v = 1,04 * h * t_w = 1,04 * 27 cm * 0,66 cm = 18,5 cm^2$$

- kontrola bočne zvrnitve (metoda tlačene pasnice)

Med montažo zagotovimo bočno podpiranje zgornjega in spodnjega pasu na polovici razpona.

$$I_{f,z} = \frac{b^3 * t_f}{12} = \frac{(13,5 cm)^3 * 1,02 cm}{12} = 209,1 cm^4$$

$$A_f = b * t_f + \frac{h_w}{6} * t_w = 13,5 cm * 1,02 cm + \frac{21,9 cm}{6} * 0,66 cm = 16,2 cm^2$$

$$i_{f,z} = \sqrt{\frac{I_{f,z}}{A_f}} = \sqrt{\frac{209,1 cm^4}{16,2 cm^2}} = 3,59 cm$$

$$\lambda_1 = 93,9 * \varepsilon = 93,9 * 1,0 = 93,9$$



$$\varepsilon = \sqrt{\frac{235}{f_y}} = \sqrt{\frac{235}{235}} = 1,0$$

$$\bar{\lambda} = \frac{k_c * \frac{L}{2}}{i_{f,z} * \lambda_1} = \frac{1,0 * \frac{500cm}{2}}{3,59cm * 93,9} = 0,74$$

uklonska krivulja b  $\rightarrow \chi_b = 0,75$

$$M_{Ed} = 45,6kNm \leq M_{b,Rd} = \chi_b * k_{f,1} * W_y * \frac{f_y}{\gamma_{M0}} = 0,75 * 1,1 * 429cm^3 * \frac{23,5 \frac{kN}{cm^2}}{1,0}$$

$$= 83,2kNm$$

#### 6.2.4 Sovprežno stanje

- obremenitev

$$q_{Ed} = 1,35 * g_a + 1,35 * g_{c1} + 1,35 * g_{ost} + 1,5 * q_k$$

$$= 1,35 * 0,35 \frac{kN}{m} + 1,35 * 7,3 \frac{kN}{m} + 1,35 * 4,25 \frac{kN}{m} + 1,5 * 10,6 \frac{kN}{m}$$

$$= 32 \frac{kN}{m}$$

$$M_{Ed} = \frac{q_{Ed} * L^2}{8} = \frac{32 \frac{kN}{m} * (5m)^2}{8} = 100kNm$$

$$V_{Ed} = \frac{q_{Ed} * L}{2} = \frac{32 \frac{kN}{m} * 5m}{2} = 80kN$$

- geometrijske karakteristike sovprežnega prereza

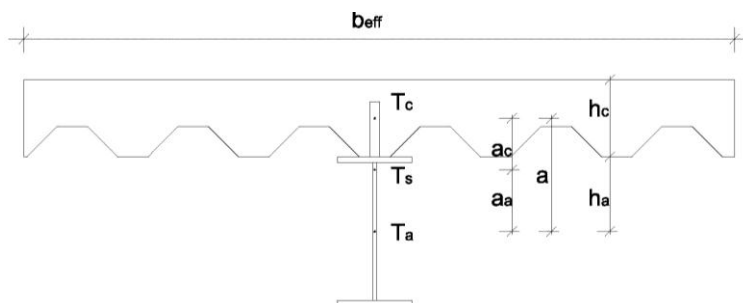

Slika 42: Geometrijske karakteristike sovprežnega prereza

$$b_{e1} = \frac{L_e}{8} = \frac{0,85 * L}{8} = \frac{0,85 * 500cm}{8} = 53,1cm$$

$$b_{eff} = 2 * b_{e1} = 2 * 53,1cm = 106,2cm$$

$$a = \frac{h_a}{2} + \frac{h_c}{2} = \frac{27cm}{2} + \frac{14cm}{2} = 20,5cm$$

$$I_a = 5790cm^4$$

$$A_a = 45,9cm^2$$

$$I_c = \frac{b_{eff} * h_c^3}{12} = \frac{106,2cm * (14cm)^3}{12} = 24284,4cm^4$$

$$A_c = b_{eff} * h_c = 106,2cm * 14cm = 1486,8cm^2$$

Pri  $t = \infty$ :

$$n_0 = \frac{E_a}{E_{cm}} = \frac{21000 \frac{kN}{cm^2}}{3100 \frac{kN}{cm^2}} = 6,77$$

$n_\infty = 2 * n_0 = 2 * 6,77 = 13,54$  (ponastavitev za stavbe, ki niso namenjene skladiščenju)

$$A_{sov} = A_a + \frac{A_c}{n_\infty} = 45,9cm^2 + \frac{1486,8cm^2}{13,54} = 155,7cm^2$$

$$a_a = a * \frac{A_c}{A_{sov} * n_\infty} = 20,5cm * \frac{1486,8cm^2}{155,7cm^2 * 13,54} = 14,46cm$$

$$a_c = a * \frac{A_a}{A_{sov}} = 20,5cm * \frac{45,9cm^2}{155,7cm^2} = 6,04cm$$

$$\begin{aligned} I_{sov} &= I_a + A_a * a_a^2 + \left( \frac{I_c + A_c * a_c^2}{n_\infty} \right) \\ &= 5790cm^4 + 45,9cm^2 * (14,46cm)^2 \\ &\quad + \left( \frac{24284,4cm^4 + 1486,8cm^2 * (6,04cm)^2}{13,54} \right) = 21186,8cm^4 \end{aligned}$$

- kontrola upogibne nosilnosti

$$N_{pl,a} = N_{c,f} = \frac{A_a * f_y}{\gamma_{M0}} = \frac{45,9cm^2 * 23,5 \frac{kN}{cm^2}}{1,0} = 1078,7kN$$

$$x_{pl} = \frac{N_{c,f}}{b_{eff} * 0,85 * \frac{f_{ck}}{\gamma_c}} = \frac{1078,7kN}{106,2cm * 0,85 * \frac{2,5 \frac{kN}{cm^2}}{1,5}} = 7,17cm < 14cm$$

$$r = \frac{h_a}{2} + h_c - \frac{x_{pl}}{2} = \frac{27cm}{2} + 14cm - \frac{7,17cm}{2} = 23,91cm$$

$$M_{Ed} = 100kNm \leq M_{pl,Rd} = N_{pl,a} * r = 1078,7kN * 0,2391m = 258kNm$$

- kontrola strižne nosilnosti

$$V_{Ed} = 80kN \leq V_{pl,Rd} = A_v * \frac{f_y}{\sqrt{3} * \gamma_{M0}} = 18,5cm^2 * \frac{23,5 \frac{kN}{m^2}}{\sqrt{3} * 1,0} = 251,4kN$$

$V_{Ed} 80kN < 0,5 * V_{pl,Rd} = 0,5 * 251,4kN = 125,7kN$  – interakcija z momentom ni potrebna

- kontrola upogibkov – MSU

$$q_{Ed}^{MSU} = g_a + g_{c1} + g_{ost} + q_k = 0,35 \frac{kN}{m} + 7,3 \frac{kN}{m} + 4,25 \frac{kN}{m} + 10,6 \frac{kN}{m} = 22,5 \frac{kN}{m}$$

$$v = \frac{5 * q_{Ed}^{MSU} * L^4}{384 * E_a * I_{sov}} = \frac{5 * 0,225 \frac{kN}{cm} * (500cm)^4}{384 * 21000 \frac{kN}{cm^2} * 21186,8cm^4} = 0,41cm$$

$$v = 0,41cm \leq \frac{L}{250} = \frac{500cm}{250} = 2cm$$

### 6.2.5 Zmanjšanje strižne nosilnosti čepov

V primeru, da čepi za končno sidranje pločevine služijo tudi kot čepi za zagotovitev sovprežnega delovanja podpornega jeklenega nosilca, je potrebno to upoštevati pri določitvi potrebnega števila čepov oz. kontroli čepov.

Običajno na tak čep sile od sidranja pločevine in sile zaradi sovprežnega delovanja jeklenega nosilca delujejo v med seboj pravokotnih smereh.

#### Kontrola strižne nosilnosti čepa

- vzdolžna strižna sila

$$F_{cf} = \min\left(A_a * \frac{f_y}{\gamma_{M0}}; A_c * 0,85 * \frac{f_{ck}}{\gamma_c}\right) = \min(1078,7kN; 2479,2kN) = 1078,7kN$$

- strižna nosilnost čepov

$$P_{Rd,s} = \frac{0,8 * f_u * \pi * d^2}{4 * \gamma_{M2}} = \frac{0,8 * 45 \frac{kN}{cm^2} * \pi * (1,9cm)^2}{4 * 1,25} = 81,7kN$$

- bočni pritisk na beton

$$P_{Rd,b} = \frac{0,29 * \alpha * d^2 * \sqrt{f_{ck} * E_{cm}}}{\gamma_{M2}} = \frac{0,29 * 1,0 * (1,9cm)^2 * \sqrt{2,5 \frac{kN}{cm^2} * 3100 \frac{kN}{cm^2}}}{1,25} = 73,7kN$$

$$\alpha = 1,0 \rightarrow \frac{h_{sc}}{d} = \frac{10cm}{1,9cm} = 5,3 > 4,0$$

- nosilnost enega čepa

$$P_{Rd} = \min\{P_{Rd,s}; P_{Rd,b}\} = \min\{81,7kN; 73,7kN\} = 73,7kN$$

- število in razporeditev čepov

$$n = \frac{F_{cf}}{P_{Rd}} = \frac{1078,7kN}{73,7kN} = 15 \text{ čepov}$$

$$e = \frac{L}{2 * n} = \frac{500cm}{30} = 16,7cm > 5 * d = 9,5cm$$

$$e = 16,7cm < \min\{6 * h_c; 80cm\} = \min\{84cm; 80cm\} = 80cm$$

Izberem 33 čepov na medsebojni razdalji 15cm.

## 7 FASADNA PODKONSTRUKCIJA

Za čelno in stransko fasado izberem Trimo fasadne panele, ki bodo pritrjeni na 0,8m in 2,2m višine etaže. Na tej višini so nameščeni tudi dodatni profili, kateri so dodatno podprti z zategami.

### Obtežba

- lastna in stalna

$$g_l = 0,34 \text{ kN/m}^2$$

$$b_2 = 1,4 \text{ m}$$

$$g = b_2 * g_l = 1,4 \text{ m} * 0,34 \frac{\text{kN}}{\text{m}^2} = 0,48 \frac{\text{kN}}{\text{m}}$$

$b_2$ .....razdalja med fasadnimi legami

- obtežba vetra

$$q_w = 0,64 \text{ kN/m}^2$$

$$q = b_2 * q_w = 1,4 \text{ m} * 0,64 \frac{\text{kN}}{\text{m}^2} = 0,9 \frac{\text{kN}}{\text{m}}$$

### Računski model

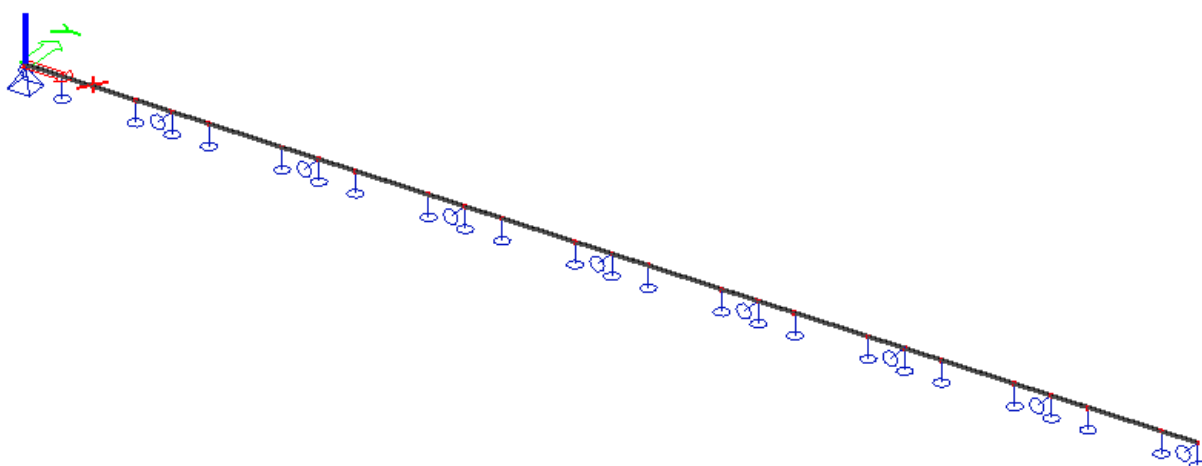

Slika 43: Zasnova modela fasadne podkonstrukcije

### Obtežne kombinacije

- MSN  $1,35 * g + 1,5 * q$
- MSU  $1,0 * g + 1,0 * q$

### Kontrola nosilnosti

Izberem profil U 100

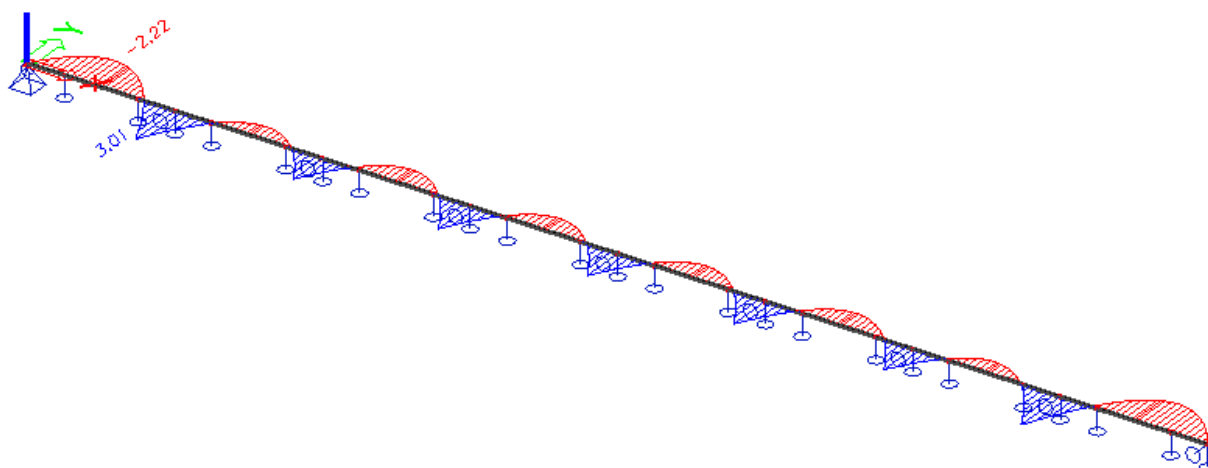

Slika 44: Ovojnica notranjih sil  $M_{Ed,y}$  [kNm] fasadne podkonstrukcije

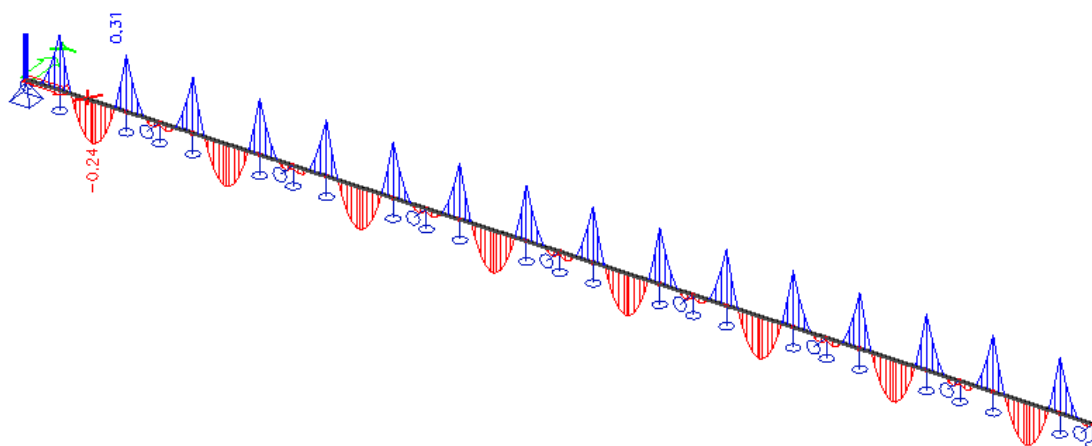

Slika 45: Ovojnica notranjih sil  $M_{Ed,z}$  [kNm] fasadne podkonstrukcije

$$M_{Ed,y} = 3,01 \text{ kNm}$$

$$M_{Ed,z} = 0,31 \text{ kNm}$$

$$M_{el,Rd,y} = W_y * \frac{f_y}{\gamma_{M0}} = 41,2 \text{ cm}^3 * \frac{23,5 \frac{\text{kN}}{\text{cm}^2}}{1,0} = 9,7 \text{ kNm}$$

$$M_{el,Rd,z} = W_z * \frac{f_y}{\gamma_{M0}} = 8,49 \text{ cm}^3 * \frac{23,5 \frac{\text{kN}}{\text{cm}^2}}{1,0} = 2,0 \text{ kNm}$$

$$\frac{M_{Ed,y}}{M_{el,Rd,y}} + \frac{M_{Ed,z}}{M_{el,Rd,z}} = \frac{3,01 \text{ kNm}}{9,7 \text{ kNm}} + \frac{0,31 \text{ kNm}}{2,0 \text{ kNm}} = 0,47 \leq 1,0$$

### Kontrola pomikov

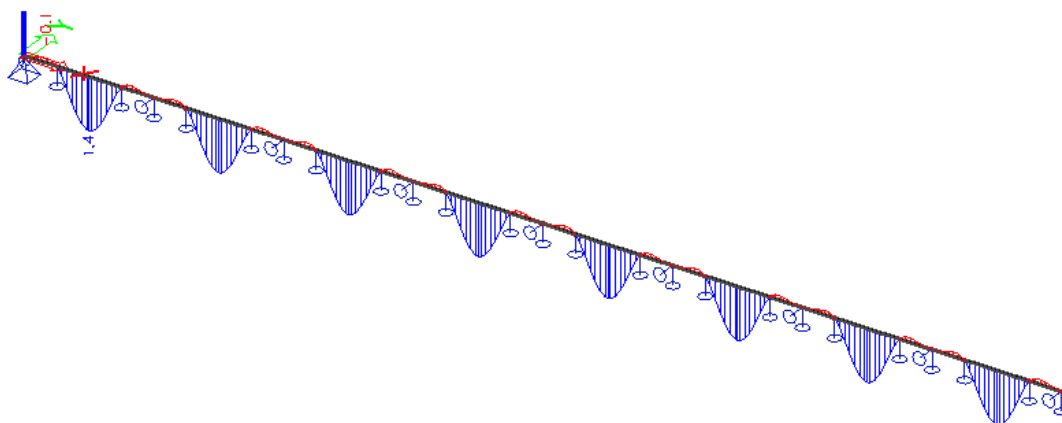

Slika 46: Ovojnica vertikalnih pomikov  $u_z$  [mm] fasadne podkonstrukcije

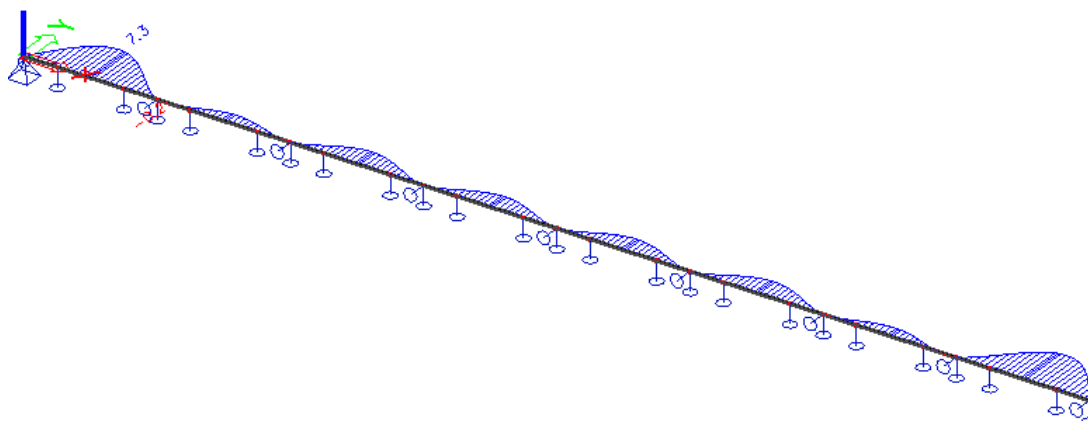

Slika 47: Ovojnica horizontalnih pomikov  $u_y$  [mm] fasadne podkonstrukcije

$$u_y = 0,73 \text{ cm} \leq \frac{L}{250} = \frac{500 \text{ cm}}{250} = 2,0 \text{ cm}$$





## 8 OCENA NOSILNOSTI TEMELJNIH TAL

Temelji so del konstrukcije, ki omogočajo, da se obremenitev stavbe razporedi na tolikšno površino, kot je potrebna za nosilnost in stabilnost objekta.

SIST EN 1997-1-2005 izpostavlja naslednje kriterije za globino temeljenja:

- doseganje ustrezne nosilnosti plasti;
- upoštevane globine, do katere glinena zemljina lahko povzroči znatne premike zaradi nabrekanja in krčenja zaradi sezonskih vremenskih sprememb;
- globina, do katere je zemljina podvržena poškodbam zaradi zmrzovanja;
- nivo talne vode in možne probleme, ki se lahko pojavijo, če je predviden izkop za temelje pod nivojem vode;
- možne premike temeljnih tal in zmanjšanje trdnosti nosilnega sloja zaradi strujenja vode, klimatskih vplivov ali gradbenih del;
- vpliv izkopa na bližnje temelje in objekte;
- pričakovane izkope za infrastrukturo v bližini temeljev;
- visoke ali nizke temperature, ki izhajajo iz objekta.

Nosilnost tal preverimo po enačbi:

$$V_d \leq R_d$$

kjer sta:

$V_d$ .....navpični projektni vpliv na temelj, v katerega mora biti vključena teža temeljev, teža zasipnega materiala, obremenitev objekta,....

$R_d$ .....odpornost (nosilnost) tal, izračunana po eni od analitičnih metod

### 8.1 Zasnova pasovnih temeljev

Objekt je lociran v Ljubljani in leži na dobro nosilni podlagi, sestavljeni iz proda debeline nekaj deset metrov. Temeljenje po plitvo s pasovnimi temelji dimenzij širine 70cm in višine 100cm. Na koti temeljenja ni prisotne talne vode.

Temelji so modelirani s linijskimi elementi na elastični podlagi, karakteristike plastičnih vzmeti so določene z modulom reakcije tal.

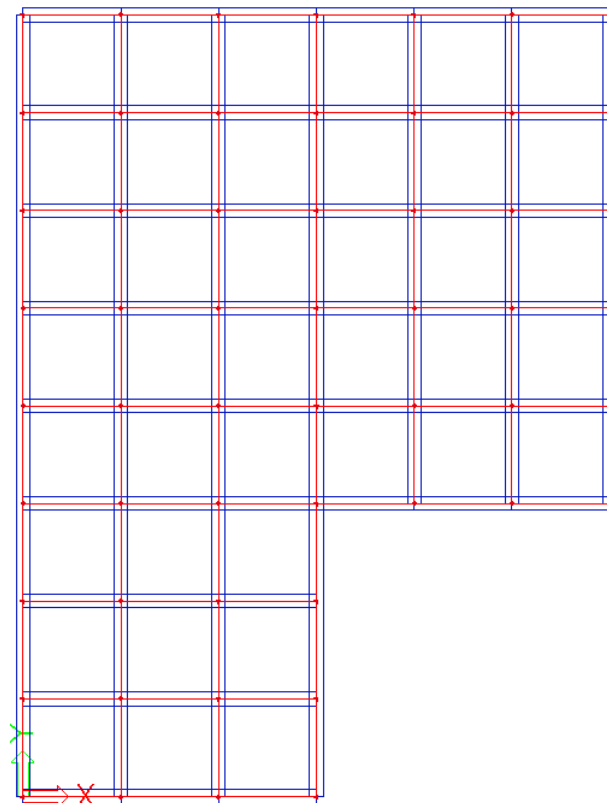

**Slika 49: Zasnova pasovnih temeljev**

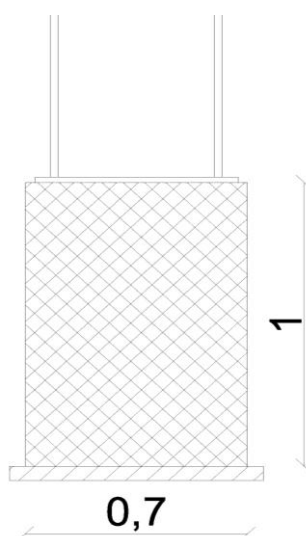

**Slika 50: Prečni prerez pasovnega temelja**

## 8.2 Obtežba na pasovne temelje

Obtežba, ki deluje na temelje:

- stalna in lastna obtežba
- koristna obtežba
- obtežba snega in
- potresna obtežba

Iz programa SCIA Engineer dobim reakcije na temelj v tekočih metrih, za mejno stanje nosilnosti in potresno kombinacijo. V programu sem že upošteval karakteristike tal, tehnične podatke temeljev in vpliv delnih faktorjev, ki jih predpisuje SIST EN 1997-1 2005.

### Obtežne kombinacije za MSN

$$1,35 * G + 1,5 * Q_1 + 0,75 * Q_s$$

$$1,35 * G + 1,5 * Q_2 + 0,75 * Q_s$$

$$1,35 * G + 1,5 * Q_3 + 0,75 * Q_s$$

### Notranje sile in reakcije za MSN

**Preglednica 13: Reakcije na temelj za MSN**

Nonlinear calculation, Extreme : Global  
Selection : All  
Class : MSN

Case	Line support	dx [m]	Rx [kN/m]	Ry [kN/m]	Rz [kN/m]	Mx [kNm/m]	My [kNm/m]	Mz [kNm/m]
NC1	Slb2	0,000	<b>-10,48</b>	1,21	112,02	0,00	-3,87	<b>0,00</b>
NC1	Slb6	0,000	<b>10,59</b>	1,18	110,96	0,00	3,80	0,00
NC1	Slb40	5,000	-1,36	<b>-9,45</b>	112,47	<b>3,89</b>	0,00	0,00
NC1	Slb15	5,000	-1,38	<b>9,34</b>	111,73	-3,78	0,00	0,00
NC2	Slb12	22,500	-3,32	-0,18	<b>71,71</b>	0,00	-1,99	0,00
NC1	Slb4	10,000	2,18	-0,05	<b>142,63</b>	0,00	0,74	0,00
NC1	Slb3	5,000	-1,38	9,12	112,02	<b>-3,83</b>	0,00	0,00
NC1	Slb12	0,000	-10,30	-1,25	112,47	0,00	<b>-3,89</b>	0,00
NC1	Slb6	40,000	10,46	-1,19	111,50	0,00	<b>3,83</b>	0,00

**Preglednica 14: Reakcije na temelj za potresno obtežno kombinacijo**

Nonlinear calculation, Extreme : Global  
 Selection : All  
 Class : Potres

Case	Line support	dx [m]	Rx [kN/m]	Ry [kN/m]	Rz [kN/m]	Mx [kNm/m]	My [kNm/m]	Mz [kNm/m]
NC10	Slb5	5,000	<b>-34,39</b>	-1,42	58,88	0,00	<b>-6,68</b>	0,00
NC11	Slb6	10,000	<b>2,10</b>	-3,08	87,95	0,00	<b>2,01</b>	0,00
NC11	Slb4	5,000	-0,70	<b>-33,63</b>	21,15	2,28	0,00	0,00
NC10	Slb15	5,000	-3,57	<b>2,46</b>	94,03	-3,90	0,00	0,00
NC11	Slb6	4,167	-1,42	-3,23	<b>11,49</b>	0,00	0,31	0,00
NC11	Slb5	10,000	-10,89	-2,88	<b>118,21</b>	0,00	-2,46	0,00
NC11	Slb3	5,000	-1,57	-14,29	70,75	<b>-3,92</b>	0,00	0,00
NC11	Slb5	0,000	-1,51	-32,04	29,69	<b>2,72</b>	0,00	0,00
NC10	Slb2	0,000	-26,14	0,07	88,43	0,00	-3,46	<b>0,00</b>

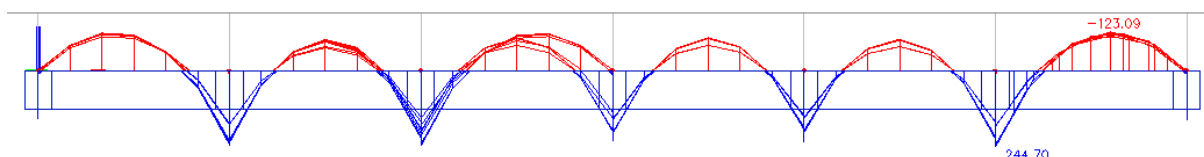

Slika 51 : Kontaktni tlaki  $M_y$  [kNm] med temeljem in zemljino za MSN

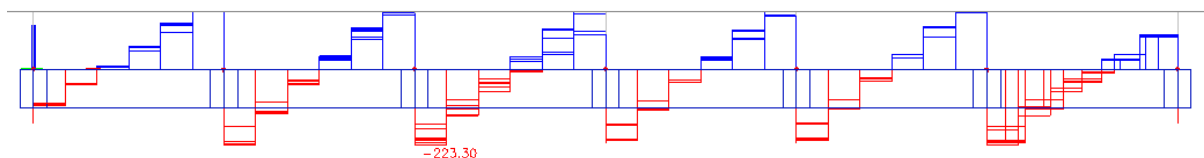

Slika 52 : Kontaktni tlaki  $V_z$  [kN] med temeljem in zemljino za MSN

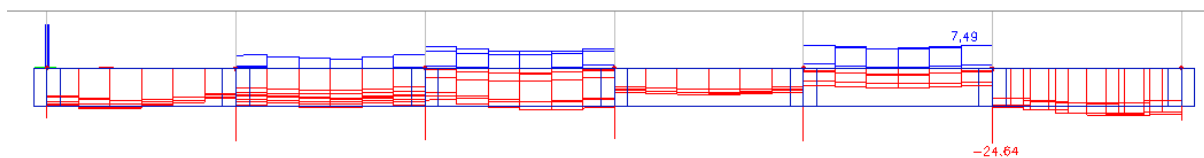

Slika 53 : Kontaktni tlaki  $N$  [kN] med temeljem in zemljino za MSN

### 8.3 Preverjanje nosilnosti temeljnih tal

#### Podatki

$B = 0,7\text{m}$

$\gamma = 20,5\text{kN/m}^3$

$c = 18\text{kN/m}^2$

$$H = 1,0\text{m} \qquad \varphi = 35^\circ \qquad \gamma_{\varphi'} = 1,4$$

$$\gamma_c = 25\text{kN/m}^3 \qquad \gamma_{\varphi} = 1,25 \qquad \gamma_{cu} = 1,4$$

### Kontrola nosilnosti

- drenirani pogoji

$$p_f = \gamma * B * N_{\gamma} + c * N_c + q * N_q$$

$$= 20,5 \frac{\text{kN}}{\text{m}^2} * 0,7\text{m} * 17,83 + 18 \frac{\text{kN}}{\text{m}^2} * 28,42 + 20,5 \frac{\text{kN}}{\text{m}^2} * 16,92 = 1114 \frac{\text{kN}}{\text{m}^2}$$

$$N_q = e^{\pi * \tan \varphi_d} * \tan^2 \left( 45 + \frac{\varphi_d}{2} \right) = e^{\pi * \tan 29,25^\circ} * \tan^2 \left( 45 + \frac{29,25^\circ}{2} \right) = 16,92$$

$$N_{\gamma} = 2 * (N_q - 1) * \tan \varphi_d = 2 * (16,92 - 1) * \tan 29,25^\circ = 17,83$$

$$N_c = \frac{(N_q - 1)}{\tan \varphi_d} = \frac{(16,92 - 1)}{\tan 29,25^\circ} = 28,42$$

$$\tan \varphi_d = \frac{\tan \varphi}{\gamma_{\varphi}} \rightarrow \varphi_d = 29,25^\circ$$

$$q = \gamma * H = 20,5 \frac{\text{kN}}{\text{m}^3} * 1,0\text{m} = 20,5 \frac{\text{kN}}{\text{m}^2}$$

$$\sigma = \max \left\{ \frac{R_z^{MSN}}{B}; \frac{R_z^{potres}}{B} \right\} = \max \left\{ \frac{142,6 \frac{\text{kN}}{\text{m}}}{0,7\text{m}}; \frac{118,2 \frac{\text{kN}}{\text{m}}}{0,7\text{m}} \right\} = \max \left\{ 203,7 \frac{\text{kN}}{\text{m}^2}; 168,9 \frac{\text{kN}}{\text{m}^2} \right\}$$

$$= 203,7 \frac{\text{kN}}{\text{m}^2} \leq p_f = 1114 \frac{\text{kN}}{\text{m}^2}$$

- nedrenirani pogoji

$$p_f = \gamma * B * N_{\gamma} + c_u * N_c + q * N_q$$

$$= 20,5 \frac{\text{kN}}{\text{m}^2} * 0,7\text{m} * 11,60 + 18 \frac{\text{kN}}{\text{m}^2} * 23,19 + 20,5 \frac{\text{kN}}{\text{m}^2} * 12,60 = 842 \frac{\text{kN}}{\text{m}^2}$$

$$N_q = e^{\pi * \tan \varphi_d} * \tan^2 \left( 45 + \frac{\varphi_d}{2} \right) = e^{\pi * \tan 29,25^\circ} * \tan^2 \left( 45 + \frac{26,57^\circ}{2} \right) = 12,60$$

$$N_{\gamma} = 2 * (N_q - 1) * \tan \varphi_d = 2 * (12,60 - 1) * \tan 29,25^\circ = 11,60$$

$$N_c = \frac{(N_q - 1)}{\tan \varphi_d} = \frac{(16,92 - 1)}{\tan 26,57^\circ} = 23,19$$

$$\tan \varphi_d = \frac{\tan \varphi}{\gamma_{\varphi'}} \rightarrow \varphi_d = 26,57^\circ$$

$$q = \gamma * H = 20,5 \frac{kN}{m^3} * 1,0m = 20,5 \frac{kN}{m^2}$$

$$\begin{aligned} \sigma &= \max \left\{ \frac{R_z^{MSN}}{B}; \frac{R_z^{potres}}{B} \right\} = \max \left\{ \frac{142,6 \frac{kN}{m}}{0,7m}; \frac{118,2 \frac{kN}{m}}{0,7m} \right\} = \max \left\{ 203,7 \frac{kN}{m^2}; 168,9 \frac{kN}{m^2} \right\} \\ &= 203,7 \frac{kN}{m^2} \leq p_f = 842 \frac{kN}{m^2} \end{aligned}$$

Napetost v temeljnih tleh v dreniranih in nedreniranih pogojih ustreza.

## 9 DIMENZIONIRANJE ZNAČILNIH SPOJEV

### 9.1 Momentni spoj prečke IPE 330 na krajni steber HEA 280

#### Zasnova

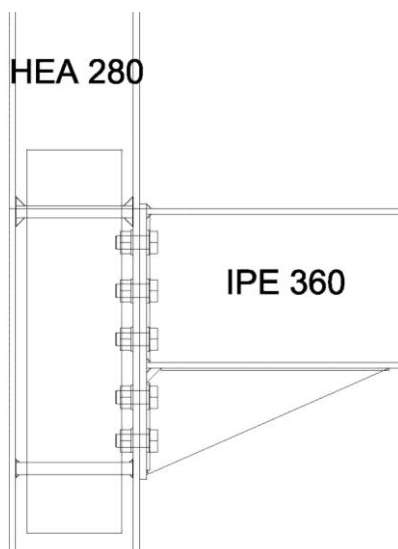

Slika 54: Zasnova momentnega spoja prečka - steber

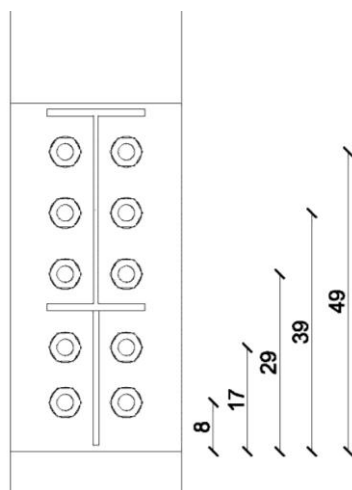

Slika 55: Razporeditev vijakov na spoju prečka - steber

#### Materiali

Jeklo S355

Vijaki M27; kvalitete 10.9  $\rightarrow f_{ub} = 100\text{kN/cm}^2$

**Obremenitev**

- varovani spoj

$$M_{pl,Rd}^{IPE330} = W_{pl,y} * \frac{f_y}{\gamma_{M0}} = 804 \text{ cm}^3 * \frac{23,5 \frac{\text{kN}}{\text{cm}^2}}{1,0} = 188,9 \text{ kNm}$$

$$M_{Ed} = 1,1 * \gamma_{ov} * M_{pl,Rd}^{IPE330} = 1,1 * 1,25 * 188,9 \text{ kNm} = 259,8 \text{ kNm}$$

$$V_{Ed} = V_{Ed,G} + V_{Ed,M} = V_{Ed,G} + \frac{2 * M_{Ed}}{L} = 40,9 \text{ kN} + \frac{2 * 259,8 \text{ kNm}}{5 \text{ m}} = 144,8 \text{ kN}$$

**Dimenzioniranje vijakov**

$$d = 27 \text{ mm} \quad A_s = 4,59 \text{ cm}^2$$

$$d_0 = 30 \text{ mm}$$

torni količnik razreda B  $\rightarrow \mu = 0,4$

$$e_1 \approx 2 * d_0 = 2 * 3 \text{ cm} = 6 \text{ cm}$$

$$p_1 \approx 3 * d_0 = 3 * 3 \text{ cm} = 9 \text{ cm}$$

$$F_{max} = \frac{M_{Ed} * r_{max}}{\sum_{i=1}^3 r_i^2} = \frac{259,8 \text{ kNm} * 0,41 \text{ m}}{(0,09 \text{ m})^2 + (0,21 \text{ m})^2 + (0,31 \text{ m})^2 + (0,41 \text{ m})^2} = 336,7 \text{ kN}$$

- kontrola natezne nosilnosti vijaka

$$F_{t,Ed} = \frac{F_{max}}{2} = \frac{336,7 \text{ kN}}{2} = 168,3 \text{ kN} \leq F_{t,Rd} = \frac{0,9 * f_{ub} * A_s}{\gamma_{Mb}} = \frac{0,9 * 100 \frac{\text{kN}}{\text{cm}^2} * 4,59 \text{ cm}^2}{1,25} = 330,5 \text{ kN}$$

- kontrola strižne nosilnosti vijaka

$$F_{v,Ed} = \frac{V_{Ed}}{n} = \frac{144,8 \text{ kN}}{10} = 14,5 \text{ kN} \leq F_{v,Rd} = \frac{0,5 * f_{ub} * A_s}{\gamma_{Mb}} = \frac{0,5 * 100 \frac{\text{kN}}{\text{cm}^2} * 4,59 \text{ cm}^2}{1,25} = 183,6 \text{ kN}$$



- interakcija nateg + strig

$$\frac{F_{v,Ed}}{F_{v,Rd}} + \frac{F_{t,Ed}}{1,4 * F_{t,Rd}} = \frac{14,5kN}{183,6kN} + \frac{168,3kN}{1,4 * 330,5kN} = 0,44 \leq 1,0$$

- kontrola preboja pločevine

Preveriti je potrebno preboj pločevine. Če pogoj ni izpolnjen, je potrebno dodati podložke ali povečati debelino čelne pločevine.

Izberem debelino čelne pločevine  $t_{\check{c}p} = 12\text{mm}$ .

$$B_{p,Rd} = \frac{0,6 * \pi * d_m * f_u * t_{\check{c}p}}{\gamma_{Mb}} = \frac{0,6 * \pi * 4,52\text{cm} * 51 \frac{kN}{cm^2} * 1,2\text{cm}}{1,25} = 417,1kN \geq F_{t,Rd}$$

$$= 330,5kN$$

- kontrola bočnih pritiskov

$$\alpha = \min \left\{ \frac{e_1}{3 * d_0} = 0,66; \frac{p_1}{3 * d_0} - \frac{1}{4} = 0,75; \frac{f_{ub}}{f_u} = 1,96; 1,0 \right\} = 0,66$$

$$t_{min} = \min \{ t_{\check{c}p}; t_f \} = \min \{ 1,2\text{cm}; 1,15\text{cm} \} = 1,15\text{cm}$$

$$k_1 = \min \left\{ 2,8 * \frac{e_1}{d_0} - 1,7 = 3,9; 1,4 * \frac{p_1}{d_0} - 1,7 = 2,5; 2,5 \right\} = 2,5$$

$$F_{b,Rd} = \frac{k_1 * \alpha * f_u * d * t_{min}}{\gamma_{Mb}} = \frac{2,5 * 0,66 * 51 \frac{kN}{cm^2} * 2,7\text{cm} * 1,15\text{cm}}{1,25} = 209kN \geq F_{v,Ed}$$

$$= 14,5kN$$

- dimenzioniranje prečne ojačitve

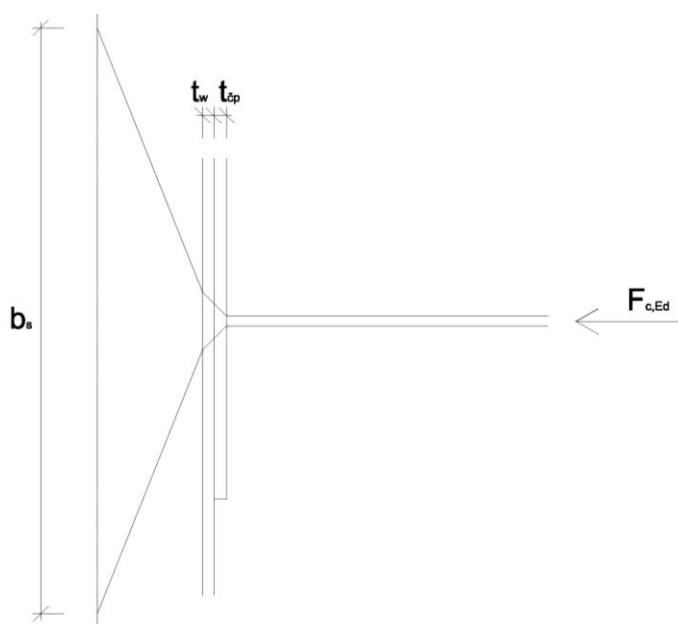

Slika 56: Sodelujoča širina stojine stebra

$$b_s = t_f^{prečke} + 2 * t_{cp} + 5 * k = 1,15cm + 2 * 1,2cm + 5 * 1,86cm = 12,85cm$$

$$k = t_f + \sqrt{2} * a = 1,15cm + \sqrt{2} * 0,5cm = 1,86cm$$

$$F_{c,Ed} = \frac{M_{Ed}}{h} = \frac{259,8kNm}{0,49m} = 530,2kN$$

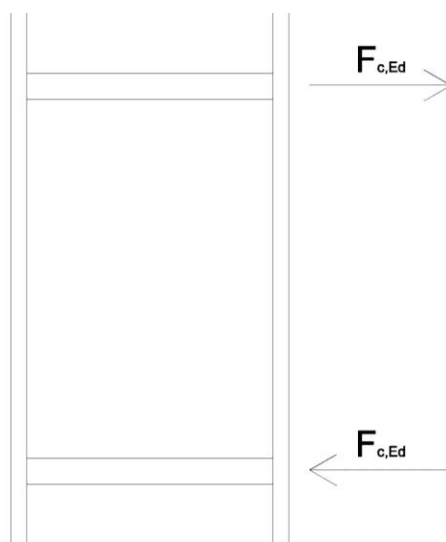

Slika 57: Delovanje obremenitve na steber

Sila, ki jo prevzame stojina stebra:

$$N_{Rd}^{stojina} = b_s * t_w * \frac{f_y}{\gamma_{M0}} = 12,85\text{cm} * 0,8\text{cm} * \frac{23,5 \frac{\text{kN}}{\text{cm}^2}}{1,0} = 241,6\text{kN}$$

Določim debelino ojačitve:

$$t_{oj} = \frac{F_{c,Ed} - N_{Rd}^{stojine}}{f_y * 2 * b_{ost}} = \frac{530,2\text{kN} - 241,6\text{kN}}{23,5 \frac{\text{kN}}{\text{cm}^2} * 2 * 7,35\text{cm}} = 0,83\text{cm}$$

Izberem  $t_{oj} = 10\text{mm}$

- kontrola strižne nosilnosti stojine stebra

$$F_{v,Rd} = \frac{d_{st} * t_w * f_y}{\gamma_{M0} * \sqrt{3}} = \frac{24,4\text{cm} * 0,8\text{cm} * 23,5 \frac{\text{kN}}{\text{cm}^2}}{1,0 * \sqrt{3}} = 264,8\text{kN}$$

Določim debelino ojačitve:

$$t_{oj} = \frac{(F_{c,Ed} - F_{v,Rd}) * \gamma_{M0} * \sqrt{3}}{f_y * (d_{st} - 20\text{mm})} = \frac{(530,2\text{kN} - 264,8\text{kN}) * 1,0 * \sqrt{3}}{23,5 \frac{\text{kN}}{\text{cm}^2} * (24,4\text{cm} - 2\text{cm})} = 0,87\text{cm}$$

Izberem  $t_{oj} = 10\text{mm}$  oziroma na vsako stran stojine dodam dodatno pločevino  $t = 6\text{mm}$ .

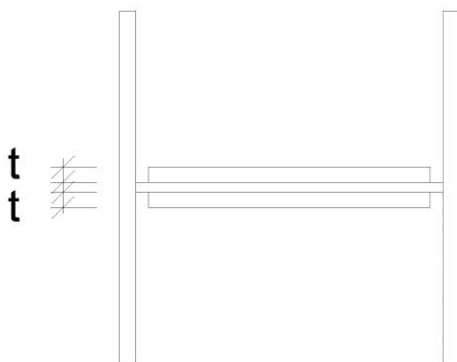

Slika 58: Dodatna pločevina na stojini stebra

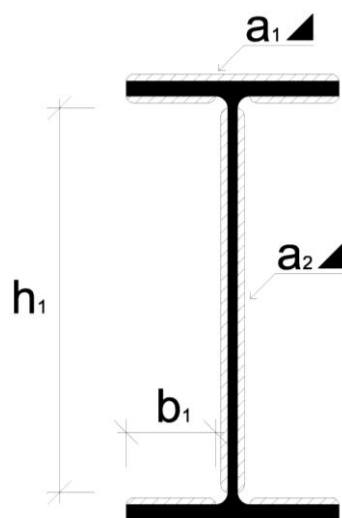
**Dimenzioniranje zvara med nosilcem in čelno pločevino**

Slika 59: Prikaz zvara med čelno pločevino in profilom

- določitev polonosilnega zvara

$$a_1 \leq 0,7 * t_1 = 0,7 * 1,15\text{cm} = 0,81\text{cm}$$

$$t_1 = \min\{t_f; t_{cp}\} = \min\{1,15\text{cm}; 1,2\text{cm}\} = 1,15\text{cm}$$

Izberem zvar debeline  $a_1 = 8\text{mm}$ .

$$a_2 \leq 0,7 * t_2 = 0,7 * 0,75\text{cm} = 0,53\text{cm}$$

$$t_2 = \min\{t_w; t_{cp}\} = \min\{0,75\text{cm}; 1,2\text{cm}\} = 0,75\text{cm}$$

Izberem zvar debeline  $a_2 = 5\text{mm}$ .

$$b_1 = \frac{b}{2} - \frac{t_w}{2} - a_1 = \frac{16\text{cm}}{2} - \frac{0,75\text{cm}}{2} - 0,8\text{cm} = 6,83\text{cm}$$

$$h_1 = h - 2 * t_f - 2 * a_2 = 33\text{cm} - 2 * 1,15\text{cm} - 2 * 0,5\text{cm} = 29,7\text{cm}$$

- kontrola nosilnosti kotnega zvara

$$\begin{aligned}
 I_{zv} &= 2 * b * a_1 * \left(\frac{h}{2}\right)^2 + 4 * b_1 * a_1 * \left(\frac{h_w}{2}\right)^2 + 2 * \left(\frac{h_1^3 * a_2}{12}\right) \\
 &= 2 * 16\text{cm} * 0,8\text{cm} * \left(\frac{33\text{cm}}{2}\right)^2 + 4 * 6,83\text{cm} * 0,8\text{cm} * \left(\frac{30,7\text{cm}}{2}\right)^2 + 2 \\
 &\quad * \left(\frac{(29,7\text{cm})^3 * 0,5\text{cm}}{12}\right) = 14302,5\text{cm}^4
 \end{aligned}$$

$$W_{zv} = \frac{2 * I_{zv}}{h} = \frac{2 * 14302,5\text{cm}^4}{33\text{cm}} = 866,8\text{cm}^3$$

$$v_{II} = \frac{V_{Ed}}{2 * a_2 * h_1} = \frac{144,8\text{kN}}{2 * 0,5\text{cm} * 29,7\text{cm}} = 4,87 \frac{\text{kN}}{\text{cm}^2}$$

$$n = \frac{M_{Ed}}{W_{zv}} = \frac{25980\text{kNcm}}{866,8\text{cm}^3} = 29,97 \frac{\text{kN}}{\text{cm}^2}$$

$$\begin{aligned}
 \sqrt{v_{II}^2 + n^2} &= \sqrt{\left(4,87 \frac{\text{kN}}{\text{cm}^2}\right)^2 + \left(29,97 \frac{\text{kN}}{\text{cm}^2}\right)^2} = 30,4 \frac{\text{kN}}{\text{cm}^2} \leq f_{v,wd} = \frac{f_u}{\sqrt{3} * \beta_w * \gamma_{M2}} \\
 &= \frac{36 \frac{\text{kN}}{\text{cm}^2}}{\sqrt{3} * 0,8 * 1,25} = 20,78 \frac{\text{kN}}{\text{cm}^2}
 \end{aligned}$$

KONTROLA SE NE IZIDE, ZATO PREDPIŠEM ČELNI ZVAR S POLNO PENETRACIJO.

## 9.2 Momentni spoj prečke IPE 500 na zunanji steber HEA 280

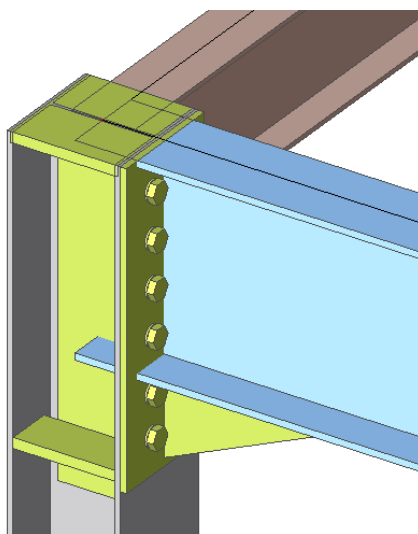

**Slika 60: Momentni spoj prečke IPE 500 na zunanji steber HEA 280**

**Preglednica 15 : Izpis kontrol iz SCIA Engineer za spoj prečke IPE 500 na zunanji steber HEA 280**

Node	N9
Lc/Combi	NC1
Beam	B7
Unity check $M/M_{Rd}$ [-]	0,24
Unity check $V/V_{Rd}$ [-]	0,05
Unity check $M/M_{Rd} + N/N_{Rd}$ [-]	0,35
Stiffness	Not applicable

### 9.3 Momentni spoj prečke IPE 360 na vmesni steber HEA 340

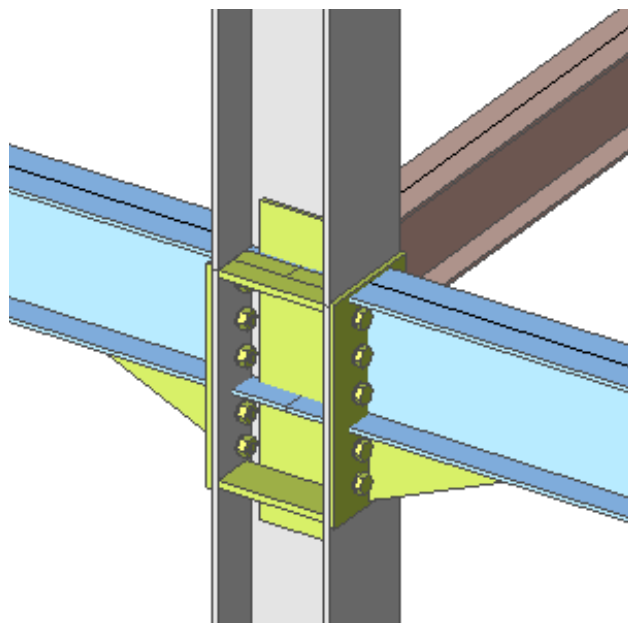

**Slika 61: Momentni spoj prečke IPE 360 na vmesni steber HEA 340**

**Preglednica 16 : Izpis kontrol iz SCIA Engineer za spoj prečke IPE 360 na vmesni steber HEA 340**

Node	N6
Lc/Combi	NC1
Beam	B5
Unity check $M/M_{Rd}$ [-]	0,79
Unity check $V/V_{Rd}$ [-]	0,08
Unity check $M/M_{Rd} + N/N_{Rd}$ [-]	0,81
Stiffness	Not applicable
Lc/Combi	NC1
Beam	B4
Unity check $M/M_{Rd}$ [-]	0,89
Unity check $V/V_{Rd}$ [-]	0,08
Unity check $M/M_{Rd} + N/N_{Rd}$ [-]	0,89
Stiffness	Not applicable

#### 9.4 Momentni spoj prečke IPE 500 na vmesni steber HEA 340

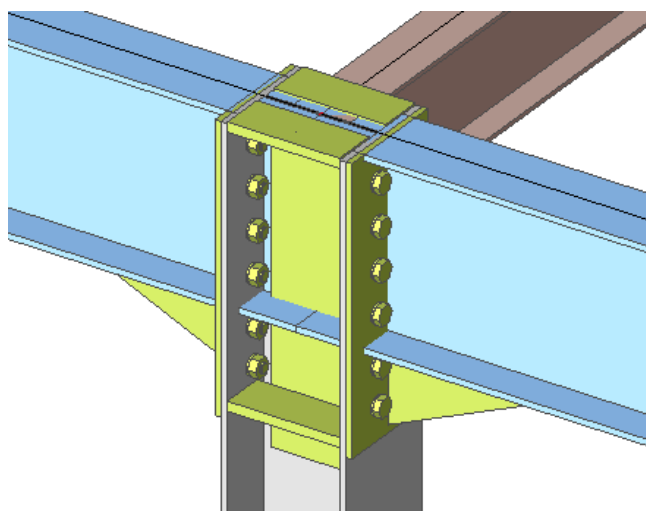

**Slika 62: Momentni spoj prečke IPE 500 na vmesni steber HEA 340**

**Preglednica 17 : Izpis kontrol iz SCIA Engineer za spoj prečke IPE 500 na vmesni steber HEA 340**

Node	N10
Lc/Combi	NC1
Beam	B8
Unity check $M/M_{Rd}$ [-]	0,73
Unity check $V/V_{Rd}$ [-]	0,06
Unity check $M/M_{Rd} + N/N_{Rd}$ [-]	0,82
Stiffness	Not applicable
Lc/Combi	NC1
Beam	B7
Unity check $M/M_{Rd}$ [-]	0,81
Unity check $V/V_{Rd}$ [-]	0,07
Unity check $M/M_{Rd} + N/N_{Rd}$ [-]	0,92
Stiffness	Not applicable

## 9.5 Členkasti spoj sekundarnega nosilca na primarni nosilec

### Zasnova

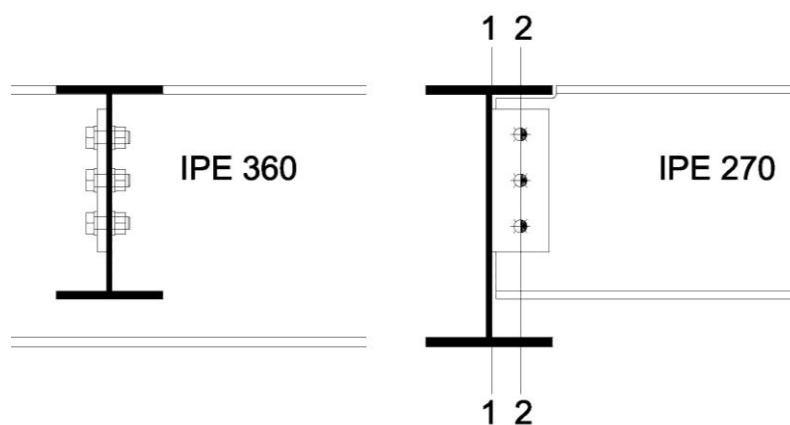



Slika 63: Zasnova členkastega spoja sekundarnega nosilca na primarni nosilec

### Materiali

Jeklo S355

Vijaki M16; kvalitete 10.9  $\rightarrow f_{ub} = 100\text{kN/cm}^2$

### Obremenitev

$V_{Ed} = 65,2\text{kN}$

### Dimenzioniranje

$d = 16\text{mm}$        $A_s = 1,57\text{cm}^2$

$d_0 = 18\text{mm}$

$$e_1 \approx 2 * d_0 = 2 * 1,8\text{cm} = 3,6\text{cm}$$

$$p_1 \approx 3 * d_0 = 3 * 1,8\text{cm} = 5,4\text{cm}$$

### Ravnina 1-1

Izberem debelino vezne pločevine  $t_{vp} = 10\text{mm}$ .



Slika 64: Shematski prikaz obremenitve v ravnini 1-1

- kontrola upogibne nosilnosti pločevine

$$M_{Ed,1} = V_{Ed} * 2e_1 = 65,2\text{kN} * 2 * 3,6\text{cm} = 4,7\text{kNm}$$

$$M_{Ed,1} = 4,7\text{kNm} \leq M_{el,Rd} = W_{el,y} * \frac{f_y}{\gamma_{M0}} = 54\text{cm}^3 * \frac{23,5 \frac{\text{kN}}{\text{cm}^2}}{1,0} = 12,7\text{kNm}$$

$$W_{el,y} = \frac{h_v^2 * t_{vp}}{6} = \frac{(18cm)^2 * 1cm}{6} = 54cm^3$$

$$h_v = 2 * (e_1 + p_1) = 2 * (3,6cm + 5,4cm) = 18cm$$

- kontrola strižne nosilnosti

$$V_{Ed} = 65,2kN \leq V_{pl,Rd} = A * \frac{f_y}{\sqrt{3} * \gamma_{M0}} = 18cm^2 * \frac{23,5 \frac{kN}{cm^2}}{\sqrt{3} * 1,0} = 244,2kN$$

Vpliva prečnih sil na projektno upogibno nosilnost preseza ni potrebno upoštevati če velja:

$$V_{Ed} = 65,2kN \leq 0,5 * V_{pl,Rd} = 122,1kN$$

- določitev polnosilnega zvara med primarnim nosilcem in vezno pločevino

$$a_1 \leq 0,7 * t_1 = 0,7 * 1,0cm = 0,7cm$$

$$t_1 = \min\{t_f; t_{vp}\} = \min\{1,15cm; 1,0cm\} = 1,0cm$$

Izberem zvar debeline  $a_1 = 7mm$

- kontrola nosilnosti kotnega zvara

$$W_{zv} = 2 * \frac{h_v^2 * a_1}{6} = 2 * \frac{(18cm)^2 * 0,7cm}{6cm} = 75,6cm^3$$

$$v_{II} = \frac{V_{Ed}}{2 * a_1 * h_v} = \frac{65,2kN}{2 * 0,7cm * 18cm} = 2,59 \frac{kN}{cm^2}$$

$$n = \frac{M_{Ed}}{W_{zv}} = \frac{470kNcm}{75,6cm^3} = 6,22 \frac{kN}{cm^2}$$

$$\begin{aligned} \sqrt{v_{II}^2 + n^2} &= \sqrt{\left(2,59 \frac{kN}{cm^2}\right)^2 + \left(6,22 \frac{kN}{cm^2}\right)^2} = 6,74 \frac{kN}{cm^2} \leq f_{v,wd} = \frac{f_u}{\sqrt{3} * \beta_w * \gamma_{M2}} \\ &= \frac{36 \frac{kN}{cm^2}}{\sqrt{3} * 0,8 * 1,25} = 20,78 \frac{kN}{cm^2} \end{aligned}$$

### Ravnina 2-2

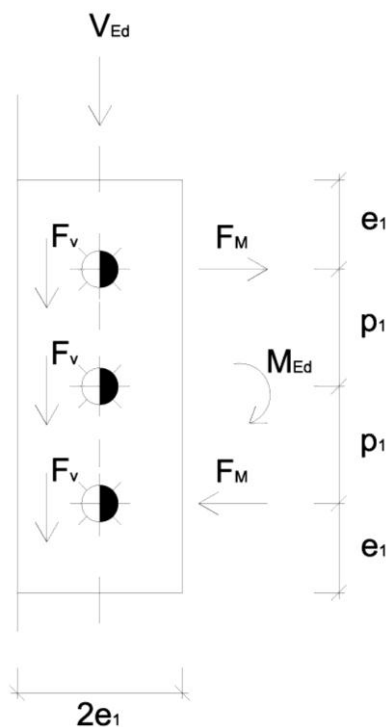

Slika 65: Shematski prikaz obremenitve v ravnini 2-2

- obremenitev

$$M_{Ed,2} = V_{Ed} * e_1 = 65,2kN * 3,6cm = 2,35kNm$$

$$F_M = \frac{M_{Ed,2}}{2 * p_1} = \frac{235kNcm}{2 * 5,4cm} = 21,8kN$$

$$F_v = \frac{V_{Ed}}{3} = \frac{65,2kN}{3} = 21,7kN$$

- kontrola strižne nosilnosti vijakov

$$F_{v,Ed} = \sqrt{F_M^2 + F_v^2} = \sqrt{(21,8kN)^2 + (21,7kN)^2} = 30,8kN$$

$$F_{v,Ed} = 30,8kN \leq F_{v,Rd} = \frac{0,6 * A_s * f_{ub}}{\gamma_{M0}} = \frac{0,6 * 1,57cm^2 * 100 \frac{kN}{cm^2}}{1,0} = 94,2kN$$

- kontrola bočnih pritiskov

$$F_{v,Ed} = 30,8kN \leq F_{b,Rd} = \frac{k_1 * \alpha * f_u * d * t_{min}}{\gamma_{Mb}} = \frac{2,5 * 0,66 * 36 \frac{kN}{cm^2} * 1,8cm * 0,66cm}{1,25}$$

$$= 56,5kN$$

$$\alpha = \min \left\{ \frac{e_1}{3 * d_0} = 0,66; \frac{p_1}{3 * d_0} - \frac{1}{4} = 0,75; \frac{f_{ub}}{f_u} = 1,96; 1,0 \right\} = 0,66$$

$$t_{min} = \min \{ t_{vp}; t_w \} = \min \{ 1,0cm; 0,66cm \} = 0,66cm$$

$$k_1 = \min \left\{ 2,8 * \frac{e_1}{d_0} - 1,7 = 3,9; 1,4 * \frac{p_1}{d_0} - 1,7 = 2,5; 2,5 \right\} = 2,5$$

- kontrola pretrga pločevine («Block Shear«)

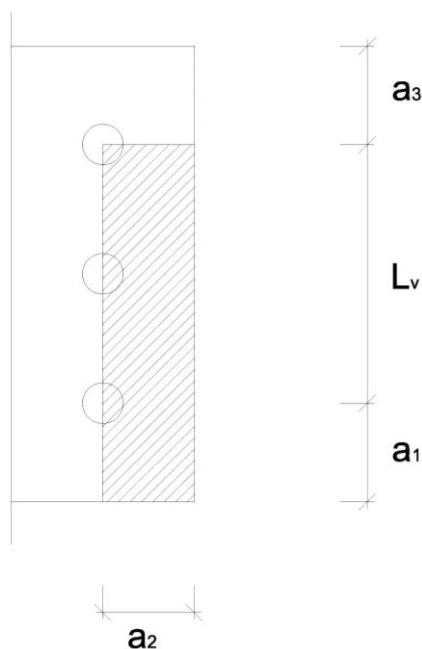

Slika 66: Strižni pretrg na robu pločevine

$$a_1 = a_2 = a_3 = e_1 = 3,6cm$$

$$L_v = 2 * p_1 = 2 * 5,4cm = 10,8cm$$

$$L_1 = a_1 = 3,6cm \leq 5 * d = 5 * 1,6cm = 8cm$$

$$L_2 = (a_2 - k * d_0) * \frac{f_u}{f_y} = (3,6cm - 0,5 * 1,8cm) * \frac{36 \frac{kN}{cm^2}}{23,5 \frac{kN}{cm^2}} = 4,1cm$$

$$L_3 = L_v + a_1 + a_3 = 10,8\text{cm} + 3,6\text{cm} + 3,6\text{cm} = 18\text{cm} \leq (L_v + a_1 + a_2 - n * d_0) * \frac{f_u}{f_y}$$

$$= (10,8\text{cm} + 3,6\text{cm} + 3,6\text{cm} - 3 * 1,8\text{cm}) * \frac{36 \frac{\text{kN}}{\text{cm}^2}}{23,5 \frac{\text{kN}}{\text{cm}^2}} = 19,3\text{cm}$$

$$L_{v,eff} = L_v + L_1 + L_2 = 10,8\text{cm} + 3,6\text{cm} + 4,1\text{cm} = 18,5\text{cm} \geq L_3 = 18\text{cm}$$

$$A_{v,eff} = t_{vp} * L_{v,eff} = 1\text{cm} * 18,5\text{cm} = 18,5\text{cm}^2$$

$$V_{Ed} = 62,5\text{kN} \leq V_{eff,Rd} = A_{v,eff} * \frac{f_y}{\sqrt{3} * \gamma_{M0}} = 18,5\text{cm}^2 * \frac{23,5 \frac{\text{kN}}{\text{cm}^2}}{\sqrt{3} * 1,0} = 251\text{kN}$$

## 9.6 Spoj stebra HEB 500 na pasovni temelj

### Zasnova

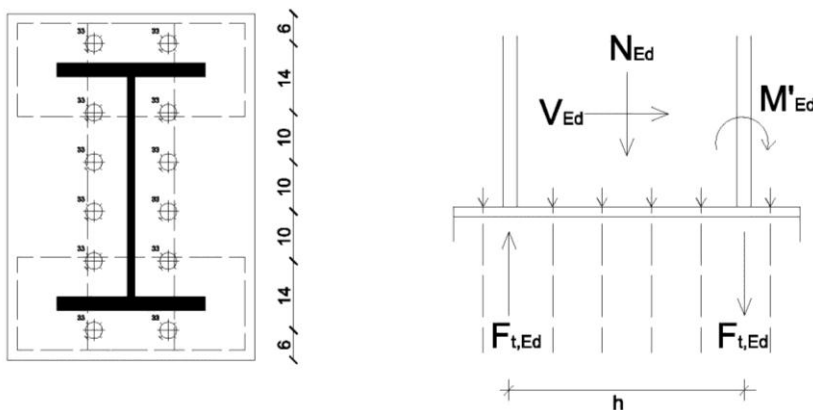

Slika 67: Priključek stebra na temelj

### Materiali

Jeklo S235, S355

Sidra S355

Beton C30/37

### Obremenitev

- varovani spoj

$$N_{Ed} = 276,2kN$$

$$M'_{Ed} = M_{pl,Rd} - N_{Ed} * \frac{h}{2} = 1131,5kNm - 276,2kN * \frac{0,472m}{2} = 1066,3kNm$$

$$M_{pl,Rd} = W_{pl,y} * \frac{f_y}{\gamma_{M0}} = 4815cm^3 * \frac{23,5 \frac{kN}{cm^2}}{1,0} = 1131,5kNm$$

$$V_{Ed} = \frac{2 * M_{pl,Rd}}{h_1} = \frac{2 * 1131,5kNm}{3,2m} = 707,2kN$$

### Dimenzioniranje

- kontrola preboja betonskega podlitja

Pri tlačno obremenjenem stebru se za vsako pasnico in stojino določi sodelujoča širina  $c$  in projektna nosilnost v tlaku  $F_{c,Rd}$ :

$$F_{c,Rd} = f_{jd} * b_{eff} * l_{eff}$$

$$c = t_p * \sqrt{\frac{f_y}{3 * f_{jd} * \gamma_{M0}}}$$

$$f_{jd} = \beta * f_{cd} * \alpha$$

Kjer so:

$f_{jd}$ .....projektna trdnost betonske podlage

$\beta$ .....koeficient podlage, za katerega se predpostavi 2/3, če so izpolnjeni naslednji pogoji:

- karakteristična trdnost podlitja ni manjša od 20% karakteristične trdnosti betona;
- debelina podlitja ni pod 20% manjše od tlorisnih dimenzij ležiščne plošče;
- pri debelini podlitja je karakteristična trdnost podlitja enaka ali večja od karakteristične trdnosti betona, vgrajenega v temelj.

$f_{cd}$ .....projektna trdnost betona

$\alpha$ .....faktor raznosa obtežbe

$f_y$ .....napetost tečenja ležiščne plošče

Izberem kvaliteto betonskega podlitja C40/50, debelino betonskega podlitja  $t_p = 50\text{mm}$  in debelino podložne pločevine  $t = 20\text{mm}$ .

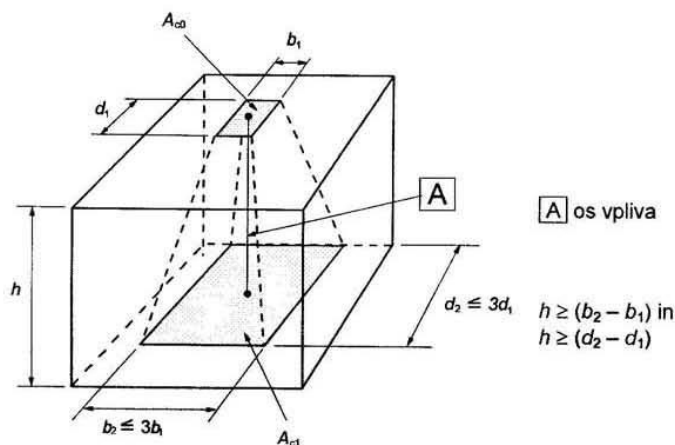

Slika 68: Projektna ploskev raznosa obtežbe pri lokalni obtežbe [SIST EN 1992-1-1 2005]

- obremenjena površina  $A_{c0}$

$$A_{c0} = A^{HEB500} = 239\text{cm}^2$$

$A_{c1}$  največja projektna ploskev raznosa obtežbe s podano obliko  $A_{c0}$ .

$$c = t_p * \sqrt{\frac{f_y}{3 * f_{jd} * \gamma_{M0}}} = 5\text{cm} * \sqrt{\frac{35,5 \frac{\text{kN}}{\text{cm}^2}}{3 * 4 \frac{\text{kN}}{\text{cm}^2} * 1,0}} = 8,6\text{cm}$$

Izberem sodelujočo širino stebra  $c = 8\text{cm}$

$$\begin{aligned} A_{c1} &= 2 * ((b^{HEB500} + 2 * c) * (t_f + 2 * c)) + (h^{HEB500} + 2 * c) * (t_w + 2 * c) \\ &= 2 * ((30\text{cm} + 2 * 8\text{cm}) * (2,8\text{cm} + 2 * 8\text{cm})) + (50\text{cm} + 2 * 8\text{cm}) \\ &\quad * (1,45\text{cm} + 2 * 8\text{cm}) = 2881,3\text{cm}^2 \end{aligned}$$

$$f_{jd} = \beta * \frac{f_{ck}}{\gamma_c} * \sqrt{\frac{A_{c1}}{A_{c0}}} = \frac{2}{3} * \frac{4 \frac{\text{kN}}{\text{cm}^2}}{1,5} * \sqrt{\frac{2881,3\text{cm}^2}{239\text{cm}^2}} = 6,17 \frac{\text{kN}}{\text{cm}^2}$$

$$F_{c,Rd} = f_{jd} * b_{eff} * l_{eff} = 6,17 \frac{kN}{cm^2} * 18,8cm * 46cm = 10671,6kN$$

$$b_{eff} = t_f + 2 * c = 2,8cm + 2 * 8cm = 18,8cm$$

$$l_{eff} = b^{HEB500} + 2 * c = 30cm + 2 * 8cm = 46cm$$

$$N_{Ed}^{max} = 1061,9kN \leq F_{c,Rd} = 10671,6kN$$

### Dimenzioniranje sidra

$$F_{t,Ed} = \frac{M'_{Ed}}{h} = \frac{1066,3kNm}{0,472m} = 2259,1kN$$

Obremenitev enega sidra:

$$F_{t,Ed}^1 = \frac{F_{t,Ed}}{n} = \frac{2259,1kN}{12} = 188,3kN$$

$$\phi \geq \sqrt{\frac{F_{t,Ed}^1 * \gamma_{Mb} * 4}{0,85 * f_y * \pi}} = \sqrt{\frac{188,3kN * 1,25 * 4}{0,85 * 35,5 \frac{kN}{cm^2} * \pi}} = 3,15cm$$

Izberem sidro  $\Phi 33$ .

- kontrola preboja pločevine

$$B_{p,Rd} = \frac{0,6 * \pi * d_m * f_u * t}{\gamma_{Mb}} = \frac{0,6 * \pi * 6,94cm * 51 \frac{kN}{cm^2} * 2cm}{1,25} = 1067,5kN \geq F_{t,Ed}^1$$

$$= 188,3kN$$

### Dimenzioniranje zvara med pločevino in stebrom HEB 500

- določitev polnonosilnega zvara

$$a_1 \leq 0,7 * t_1 = 0,7 * 2cm = 1,4cm$$

$$t_1 = \min\{t_f; t_{\check{c}p}\} = \min\{2,8cm; 2cm\} = 2cm$$

Izberem zvar debeline  $a_1 = 14mm$ .

$$a_2 \leq 0,7 * t_2 = 0,7 * 1,45cm = 1,02cm$$



$$t_2 = \min\{t_w; t_{cp}\} = \min\{1,45\text{cm}; 2\text{cm}\} = 1,45\text{cm}$$

Izberem zvar debeline  $a_2 = 10\text{mm}$ .

$$b_1 = \frac{b}{2} - \frac{t_w}{2} - a_1 = \frac{30\text{cm}}{2} - \frac{1,45\text{cm}}{2} - 1,4\text{cm} = 12,88\text{cm}$$

$$h_1 = h - 2 * t_f - 2 * a_2 = 50\text{cm} - 2 * 2,8\text{cm} - 2 * 1\text{cm} = 42,4\text{cm}$$

- kontrola nosilnosti kotnega zvara

$$\begin{aligned} I_{zv} &= 2 * b * a_1 * \left(\frac{h}{2}\right)^2 + 4 * b_1 * a_1 * \left(\frac{h_w}{2}\right)^2 + 2 * \left(\frac{h_1^3 * a_2}{12}\right) \\ &= 2 * 30\text{cm} * 1,4\text{cm} * \left(\frac{50\text{cm}}{2}\right)^2 + 4 * 12,88\text{cm} * 1,4\text{cm} * \left(\frac{44,4\text{cm}}{2}\right)^2 + 2 \\ &\quad * \left(\frac{(42,4\text{cm})^3 * 1\text{cm}}{12}\right) = 100751,7\text{cm}^4 \end{aligned}$$

$$W_{zv} = \frac{2 * I_{zv}}{h} = \frac{2 * 100751,7\text{cm}^4}{50\text{cm}} = 4030,1\text{cm}^3$$

$$v_{II} = \frac{V_{Ed}}{2 * a_2 * h_1} = \frac{707,2\text{kN}}{2 * 1\text{cm} * 42,4\text{cm}} = 8,34 \frac{\text{kN}}{\text{cm}^2}$$

$$n = \frac{M_{Ed}}{W_{zv}} = \frac{106630\text{kNcm}}{4030,1\text{cm}^3} = 26,46 \frac{\text{kN}}{\text{cm}^2}$$

$$\begin{aligned} \sqrt{v_{II}^2 + n^2} &= \sqrt{\left(8,34 \frac{\text{kN}}{\text{cm}^2}\right)^2 + \left(26,46 \frac{\text{kN}}{\text{cm}^2}\right)^2} = 27,7 \frac{\text{kN}}{\text{cm}^2} \leq f_{v,wd} = \frac{f_u}{\sqrt{3} * \beta_w * \gamma_{M2}} \\ &= \frac{36 \frac{\text{kN}}{\text{cm}^2}}{\sqrt{3} * 0,8 * 1,25} = 20,78 \frac{\text{kN}}{\text{cm}^2} \end{aligned}$$

KONTROLA SE NE IZIDE, ZATO PREDPIŠEM ČELNI ZVAR S POLNO PENETRACIJO.

## 9.7 Priključek diagonale na steber HEA 280

### Zasnova

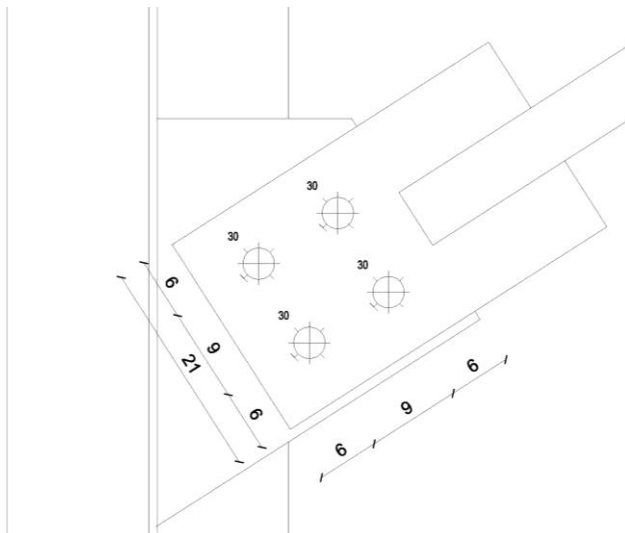

Slika 69: Zasnova spoja diagonale na steber

### Materiali

Jeklo S235, S355

Vijaki M24; kvalitete 10.9  $\rightarrow f_{ub} = 100 \text{ kN/cm}^2$

### Obremenitev

- spoj je varovan

Obremenitev v diagonali VHP60/60x6mm.

$$N_{Ed} = 1,1 * \gamma_{ov} * N_{pl,Rd} = 1,1 * 1,25 * 282 \text{ kN} = 387,8 \text{ kN}$$

$$N_{pl,Rd} = A * \frac{f_y}{\gamma_{M0}} = 12 \text{ cm}^2 * \frac{23,5 \frac{\text{kN}}{\text{cm}^2}}{1,0} = 282 \text{ kN}$$

### Dimenzioniranje vijakov

Izberem debelino pločevine  $t = 7 \text{ mm}$ .

$$d = 27 \text{ mm} \quad A_s = 4,59 \text{ cm}^2$$

$d_0 = 30\text{mm}$

$$e_1 \approx 2 * d_0 = 2 * 3\text{cm} = 6\text{cm}$$

$$p_1 \approx 3 * d_0 = 3 * 3\text{cm} = 9\text{cm}$$

- kontrola torne nosilnosti vijakov

$$F_{p,c,d} = 0,7 * f_{ub} * A_s = 0,7 * 100 \frac{\text{kN}}{\text{cm}^2} * 4,59\text{cm}^2 = 321,3\text{kN}$$

$$F_{s,R,d} = \frac{k_s * n * \eta * F_{p,c,d}}{\gamma_{MS}} = \frac{1,0 * 1,0 * 0,4 * 321,3\text{kN}}{1,25} = 102,8\text{kN}$$

$$F_{v,E,d} = \frac{N_{E,d}}{n} = \frac{387,8\text{kN}}{4} = 97\text{kN} \leq F_{s,R,d} = 102,8\text{kN}$$

- kontrola bočne nosilnosti vijakov

$$F_{b,R,d} = \frac{2,5 * \alpha * f_u * d * t}{\gamma_{Mb}} = \frac{2,5 * 0,66 * 51 \frac{\text{kN}}{\text{cm}^2} * 2,7\text{cm} * 0,8\text{cm}}{1,25} = 145,4\text{kN}$$

$$\alpha = \min \left\{ \frac{e_1}{3 * d_0} = 0,66; \frac{p_1}{3 * d_0} - \frac{1}{4} = 0,75; \frac{f_{ub}}{f_u} = 1,96; 1,0 \right\} = 0,66$$

$$F_{v,E,d} = 97\text{kN} \leq F_{b,R,d} = 145,4\text{kN}$$

- kontrola neto preseka

$$N_{E,d} = 387,8\text{kN} \leq N_{pl,R,d}^{neto} = A_{neto} * \frac{f_y}{\gamma_{M0}} = 12\text{cm}^2 * \frac{35,5 \frac{\text{kN}}{\text{cm}^2}}{1,0} = 426\text{kN}$$

$$A_{neto} = (b - 2 * d_0) * t = (21\text{cm} - 2 * 3\text{cm}) * 0,8\text{cm} = 12\text{cm}^2$$

$$b = 2 * e_1 + p_1 = 2 * 6\text{cm} + 9\text{cm} = 21\text{cm}$$

### **Dimenzioniranje zvara med diagonalo in pločvino**

- določitev polnosilnega zvara

$$a_1 \leq 0,7 * t_1 = 0,7 * 0,6\text{cm} = 0,42\text{cm}$$

$$t_1 = \min\{t_f; t\} = \min\{0,6\text{cm}; 0,8\text{cm}\} = 0,6\text{cm}$$

Izberem zvar debeline  $a_1 = 5\text{mm}$ .

- kontrola nosilnosti kotnega zvara

$$A_w = 4 * a_1 * l_{zv1} = 4 * 0,5\text{cm} * 15\text{cm} = 30\text{cm}^2$$

$$v_{II} = \frac{N_{Ed}}{A_w} = \frac{387,8\text{kN}}{30\text{cm}^2} = 12,93 \frac{\text{kN}}{\text{cm}^2}$$

$$\begin{aligned} \sqrt{v_{II}^2} &= \sqrt{\left(12,93 \frac{\text{kN}}{\text{cm}^2}\right)^2} = 12,93 \frac{\text{kN}}{\text{cm}^2} \leq f_{v,wd} = \frac{f_u}{\sqrt{3} * \beta_w * \gamma_{M2}} = \frac{36 \frac{\text{kN}}{\text{cm}^2}}{\sqrt{3} * 0,8 * 1,25} \\ &= 20,78 \frac{\text{kN}}{\text{cm}^2} \end{aligned}$$

### Dimenzioniranje zvara med pločevino in stebrom HEA 280

- določitev polnonosilnega zvara

$$a_2 \leq 0,7 * t_2 = 0,7 * 0,8\text{cm} = 0,56\text{cm}$$

$$t_2 = \min\{t_w; t\} = \min\{0,8\text{cm}; 0,8\text{cm}\} = 0,8\text{cm}$$

Izberem zvar debeline  $a_2 = 5\text{mm}$ .

- obremenitev v zvaru

$$\alpha = 32,62^\circ$$

$$F_{M\perp} = N_{Ed} * \cos \alpha = 387,8\text{kN} * \cos 32,62^\circ = 326,6\text{kN}$$

$$F_{MII} = N_{Ed} * \sin \alpha = 387,8\text{kN} * \sin 32,62^\circ = 209,1\text{kN}$$

- kontrola nosilnosti kotnega zvara

$$v_{II} = \frac{F_{MII}}{2 * a_2 * l_{zv2}} = \frac{209,1\text{kN}}{2 * 0,5\text{cm} * 20\text{cm}} = 10,45 \frac{\text{kN}}{\text{cm}^2}$$

$$v_{\perp} = \frac{F_{M\perp}}{2 * a_2 * l_{zv2}} = \frac{326,6\text{kN}}{2 * 0,5\text{cm} * 20\text{cm}} = 16,33 \frac{\text{kN}}{\text{cm}^2}$$

---

$$\begin{aligned}\sqrt{v_{II}^2 + v_I^2} &= \sqrt{\left(10,45 \frac{kN}{cm^2}\right)^2 + \left(16,33 \frac{kN}{cm^2}\right)^2} = 19,38 \leq f_{v,wd} = \frac{f_u}{\sqrt{3} * \beta_w * \gamma_{M2}} \\ &= \frac{36 \frac{kN}{cm^2}}{\sqrt{3} * 0,8 * 1,25} = 20,78 \frac{kN}{cm^2}\end{aligned}$$

## **10 ZAKLJUČEK**

V okviru diplomske naloge sem izdelal statično analizo trietažnega poslovnega objekta. Objekt sem sestavil iz jeklenih okvirjev, v prečni smeri z momentnim okvirjem v vzdolžni smeri iz okvirjev z centričnim povezjem. V horizontalni smeri sem objekt povezal z AB sovprežnimi ploščami.

Objekt sem obtežil s pripadajočimi obtežbami, katere sem pridobil iz evropskega standarda. Modeliral sem na prostorskem modelu z upoštevanjem nadomestne globalne nepopolnosti. Pri potresni analizi sem preveril kriterije za doseganje ustreznega porušnega mehanizma in pri tem spoznal, da imajo posebne zahteve za konstrukcije velik vpliv.

V okviru diplomske naloge sem dimenzioniral tudi spoje, temelje, fasadne lege in medetažno konstrukcijo po veljavnih evropskih standardih.

Pri pisanju diplomske naloge sem poleg teoretičnega znanja, ki sem ga pridobil v okviru študija, potreboval tudi veliko samoiniciativnosti, truda, vztrajnosti in kritičnega mišljenja za reševanje praktičnih problemov.

## VIRI

Analiza TRIMO HI-Bond sovprežnih stropov.

<http://www.fgg.uni-lj.si/kmk/Tabele%20za%20dimenzioniranje%20sovpre%20C5%20BEnih%20stropov%20s%20HI%20BOND.pdf> (5.3.2011)

Beg, D. 1999. Projektiranje jeklenih konstrukcij po evropskem predstandardu ENV 1993-1-1. Ljubljana, Univerza v Ljubljani, Fakulteta za gradbeništvo in geodezijo: 219 str.

Ognjevarni paneli trimoterm.

[http://www.trimo.si/media/ognjevarni-paneli-trimoterm\\_7838.pdf](http://www.trimo.si/media/ognjevarni-paneli-trimoterm_7838.pdf) (5.3.2011)

SIST EN 1990: Evrokod – Osnove projektiranja konstrukcij (istoveten EN 1990:2000), september 2004

SIST EN 1991: Evrokod1: Vplivi na konstrukcije - 1-1. del: Splošni vplivi – Prostorninske teže, lastna teža, koristne obtežbe stavb (istoveten z EN 1991-1-1:2000), september 2004

SIST EN 1991: Evrokod1: Vplivi na konstrukcije - 1-1. del: Splošni vplivi – Prostorninske teže, lastna teža, koristne obtežbe stavb – Nacionalni dodatek, september 2004/A101

SIST EN 1991: Evrokod1: Vplivi na konstrukcije - 1-3. del: Splošni vplivi – Obtežba snega, september 2004

SIST EN 1991: Evrokod1: Vplivi na konstrukcije - 1-3. del: Splošni vplivi – Obtežba snega – Nacionalni dodatek, januar 2008/A101

SIST EN 1991: Evrokod1: Vplivi na konstrukcije - 1-3. del: Splošni vplivi – Vpliv vetra, oktober 2005

SIST EN 1991: Evrokod1: Vplivi na konstrukcije - 1-3. del: Splošni vplivi – Vpliv vetra – Nacionalni dodatek, oktober 2007/A101

SIST EN 1992: Evrokod2: Projektiranje betonskih konstrukcij - 1-1. del: Splošna pravila in pravila za stavbe, maj 2005

SIST EN 1992: Evrokod2: Projektiranje betonskih konstrukcij - 1-1. del: Splošna pravila in pravila za stavbe – Nacionalni dodatek, marec 2006/A101

SIST EN 1993: Evrokod3: Projektiranje jeklenih konstrukcij - 1-1. del: Splošna pravila in pravila za stavbe, oktober 2005

SIST EN 1993: Evrokod3: Projektiranje jeklenih konstrukcij - 1-1. del: Splošna pravila in pravila za stavbe – Nacionalni dodatek, marec 2006/A101

SIST EN 1993: Evrokod3: Projektiranje jeklenih konstrukcij - 1-8. del: Projektiranje spojev, oktober 2005

SIST EN 1993: Evrokod3: Projektiranje jeklenih konstrukcij - 1-8. del: Projektiranje spojev – Nacionalni dodatek, marec 2006/A101

SIST EN 1994: Evrokod4: Projektiranje sovprežnih konstrukcij iz jekla in betona - 1-1. del: Splošna pravila in pravila za stavbe, maj 2005

SIST EN 1994: Evrokod4: Projektiranje sovprežnih konstrukcij iz jekla in betona - 1-1. del: Splošna pravila in pravila za stavbe – Nacionalni dodatek, marec 2006/A101

SIST EN 1997: Evrokod7: Geotehnično projektiranje - 1. del: Splošna pravila, maj 2005

SIST EN 1997: Evrokod7: Geotehnično projektiranje - 1. del: Splošna pravila – Nacionalni dodatek, marec 2006/A101

SIST EN 1998: Evrokod8: Projektiranje potresnoodpornih konstrukcij - 1. del: Splošna pravila, potresni vplivi in pravila za stavbe, maj 2005

SIST EN 1998: Evrokod8: Projektiranje potresnoodpornih konstrukcij - 1. del: Splošna pravila, potresni vplivi in pravila za stavbe – Nacionalni dodatek, marec 2006/A101



Sekereš, D. 2011. Statični izračun jeklenega trietažnega poslovnega objekta.

Dipl. nal. – VSŠ. Ljubljana, UL, FGG, Odd. za gradbeništvo, Konstrukcijska smer.

---

## **KAZALO PRILOG**

PRILOGA A: Izpis rezultatov in kontrol za jeklen okvir iz programa SCIA Engineer

PRILOGA B: Izpis rezultatov in kontrol za fasadno podkonstrukcijo iz programa SCIA Engineer

PRILOGA C: Izpis rezultatov in kontrol za spoje iz programa SCIA Engineer

PRILOGA D: Pozicijski načrti in detajli

Sekereš, D. 2011. Statični izračun jeklenega trietažnega poslovnega objekta.

Dipl. nal. – VSŠ. Ljubljana, UL, FGG, Odd. za gradbeništvo, Konstrukcijska smer.

---

## **PRILOGA A: Izpis rezultatov in kontrol za jeklen okvir iz programa SCIA Engineer**

### Okvir v prečni smeri

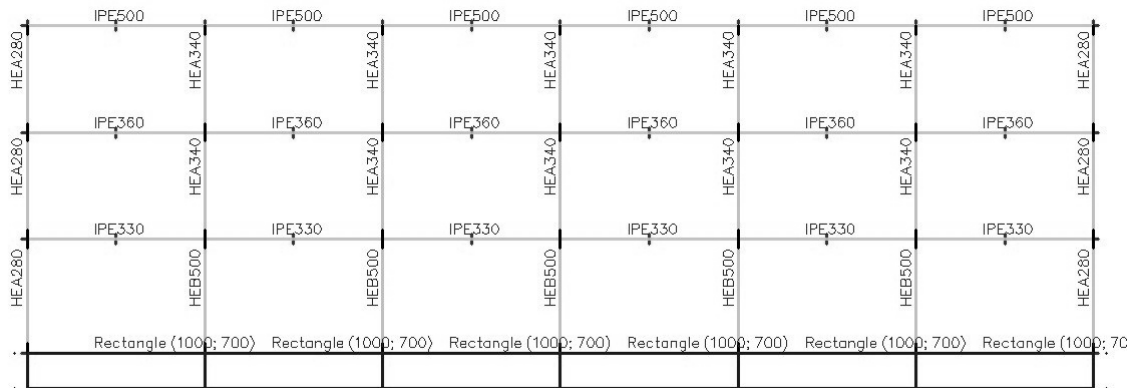

### Okvir v vzdolžni smeri

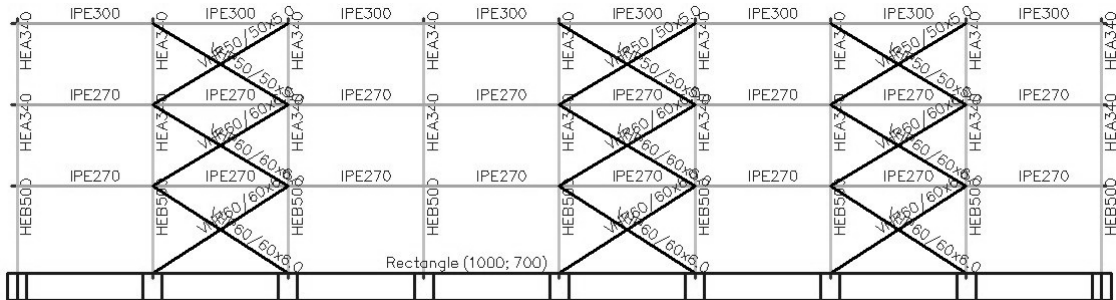

### Material

Name	Unit mass [kg/m <sup>3</sup> ]	E mod [MPa]	Poisson - nu	G mod [MPa]	Thermal exp [1/mK]	Lower limit [mm]	Upper limit [mm]	Fy [MPa]	Fu [MPa]
*Student version* *Student version* *Student version* *Student version* *Student version* *Student version* *Student version* *Student version* *Student version									
S 235	7850,00	2,1000e+05	0,3	8,0769e+04	0,01e-003	0	40	235,0	360,0
						40	80	215,0	360,0
Name	Type	Unit mass [kg/m <sup>3</sup> ]	E mod [MPa]	Poisson - nu	G mod [MPa]	Thermal exp [m/mK]	Characteristic compressive cylinder strength fck(28) [MPa]		
*Student version* *Student version* *Student version* *Student version* *Student version* *Student version* *Student version* *Student version* *Student version									
C30/37	Concrete	2500,00	3,2800e+04	0,2	1,3667e+04	0,01e-003	30,00		

### Stalna obtežba G

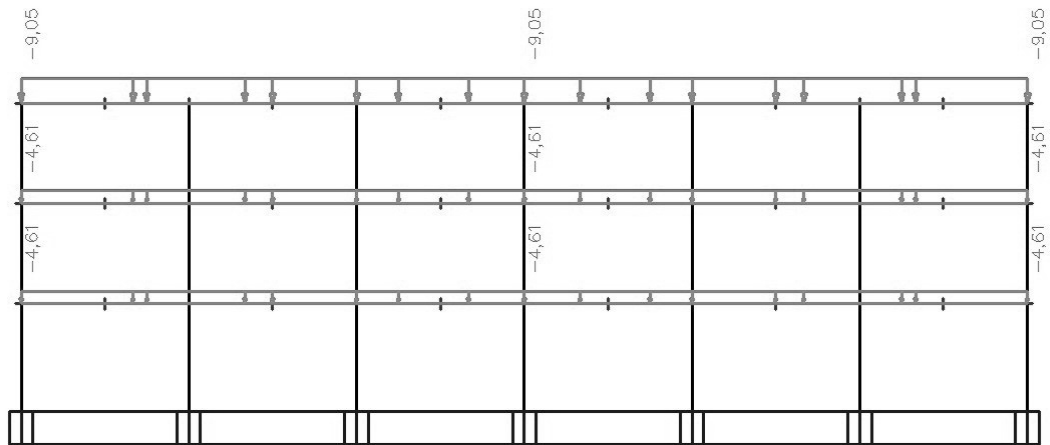

### Koristna obtežba Q1

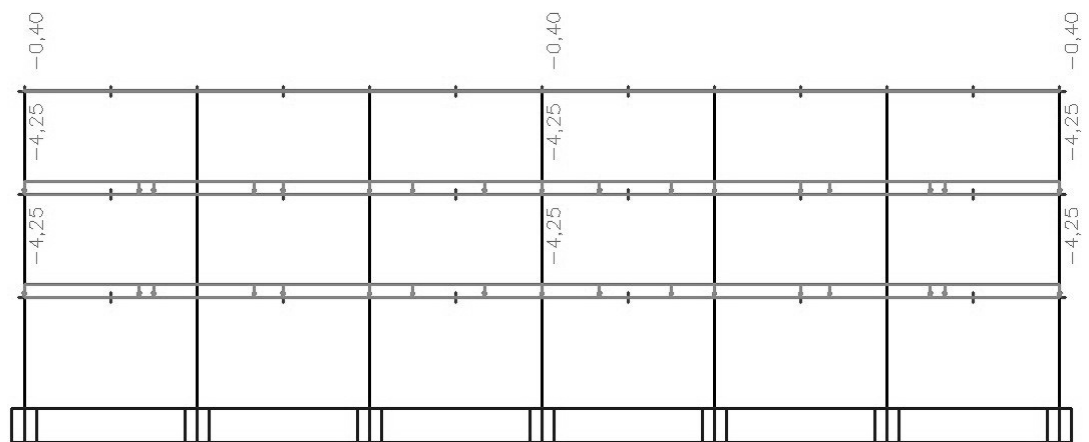

### Koristna obtežba Q2

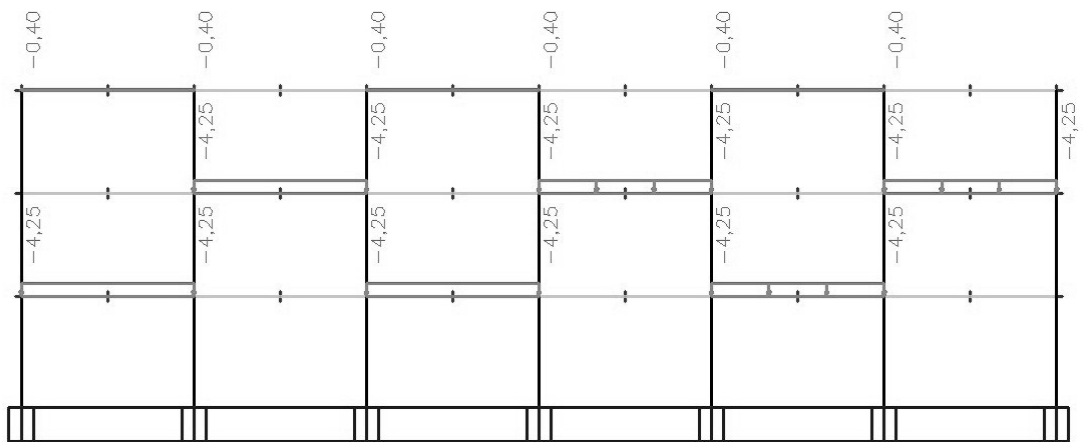

### Koristna obtežba Q3

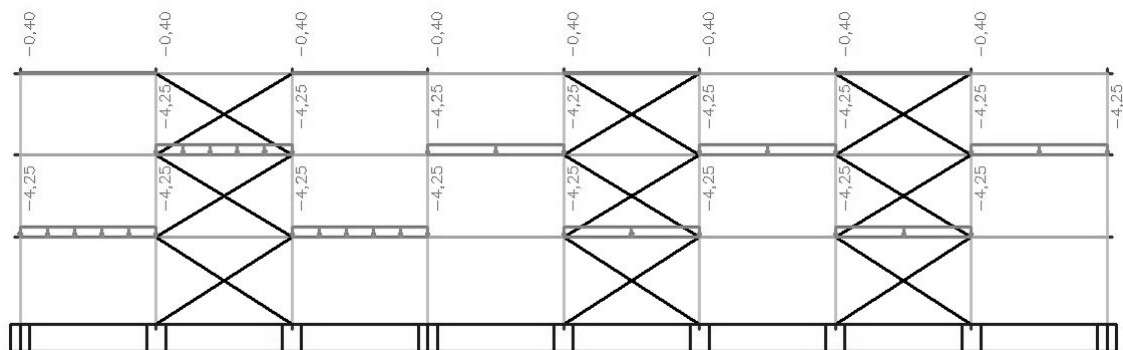

### Obtežba snega Qs

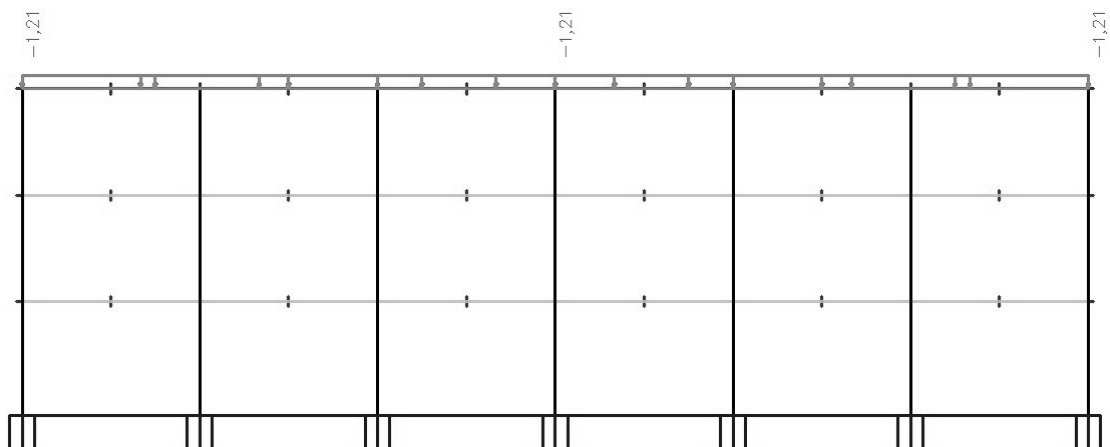



Name	Type	Load cases	Coeff. [-]
NC6	Ultimate	Q3	1,00
		Qs	0,50
NC7	Ultimate	Q1	1,00
		Qs	0,50
NC8	Ultimate	Q2	1,00
		Qs	0,50
NC9	Ultimate	Q3	1,00
		Qs	0,50
NC10	Ultimate	G1	1,00
		G	1,00
		Ax	1,00
		Ay	0,30
NC11	Ultimate	G1	1,00
		G	1,00
		Ax	0,30
		Ay	1,00
NC12	Ultimate	G1	1,00
		G	1,00
NC13	Ultimate	Ax	1,00
		Ay	0,30
NC14	Ultimate	Ax	0,30
		Ay	1,00

### Reakcije v kNm za MSN

Nonlinear calculation, Extreme : Global  
 Selection : All  
 Class : MSN

Case	Line support	dx [m]	Rx [kN/m]	Ry [kN/m]	Rz [kN/m]	Mx [kNm/m]	My [kNm/m]	Mz [kNm/m]
NC1	Slb2	0,000	<b>-10,36</b>	1,21	111,52	0,00	-3,82	<b>0,00</b>
NC1	Slb6	0,000	<b>10,47</b>	1,18	110,45	0,00	3,75	0,00
NC1	Slb40	5,000	-1,35	<b>-9,40</b>	111,95	<b>3,88</b>	0,00	0,00
NC1	Slb15	5,000	-1,36	<b>9,27</b>	111,02	-3,75	0,00	0,00
NC2	Slb12	22,500	-3,28	-0,18	<b>71,32</b>	0,00	-1,95	0,00
NC1	Slb4	10,000	2,21	-0,05	<b>143,26</b>	0,00	0,77	0,00
NC1	Slb3	5,000	-1,37	9,16	111,52	<b>-3,80</b>	0,00	0,00
NC1	Slb12	0,000	-10,18	-1,24	111,95	0,00	<b>-3,83</b>	0,00
NC1	Slb6	40,000	10,33	-1,18	110,99	0,00	<b>3,77</b>	0,00

### Reakcije v kNm za potresno obtežno kombinacijo

Nonlinear calculation, Extreme : Global  
 Selection : All  
 Class : Potres

Case	Line support	dx [m]	Rx [kN/m]	Ry [kN/m]	Rz [kN/m]	Mx [kNm/m]	My [kNm/m]	Mz [kNm/m]
NC10	Slb5	5,000	<b>-33,77</b>	-1,38	58,66	0,00	<b>-6,49</b>	0,00
NC11	Slb6	10,000	<b>1,81</b>	-3,06	86,81	0,00	<b>1,93</b>	0,00
NC11	Slb4	5,000	-0,73	<b>-32,37</b>	22,44	2,20	0,00	0,00
NC10	Slb15	5,000	-3,62	<b>2,22</b>	92,54	<b>-3,80</b>	0,00	0,00
NC11	Slb6	4,167	-1,55	-3,18	<b>12,27</b>	0,00	0,26	0,00
NC11	Slb5	10,000	-10,76	-2,85	<b>116,32</b>	0,00	-2,40	0,00
NC11	Slb5	0,000	-1,48	-31,00	31,83	<b>2,73</b>	0,00	0,00
NC10	Slb2	0,000	-26,43	0,08	87,86	0,00	-3,51	<b>0,00</b>

Osna sila N [kN] za MSN

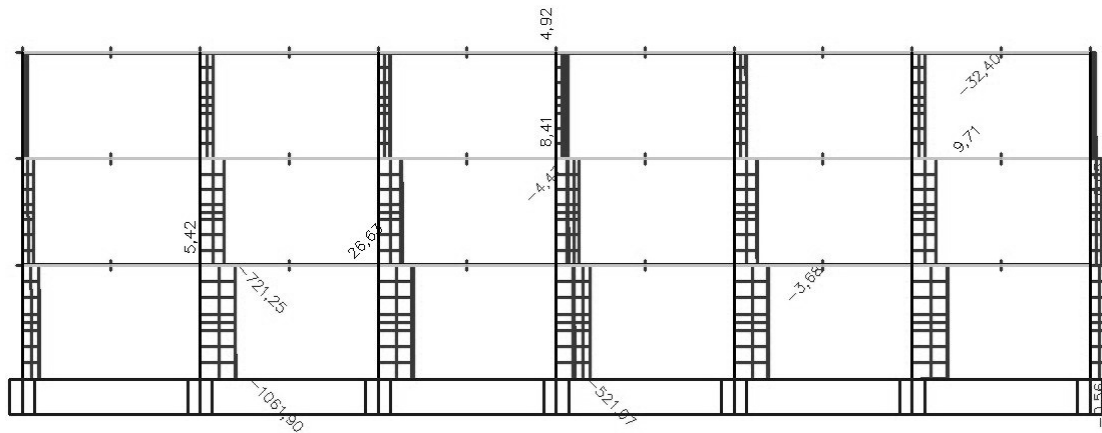

Prečna sila Vz [kN] za MSN

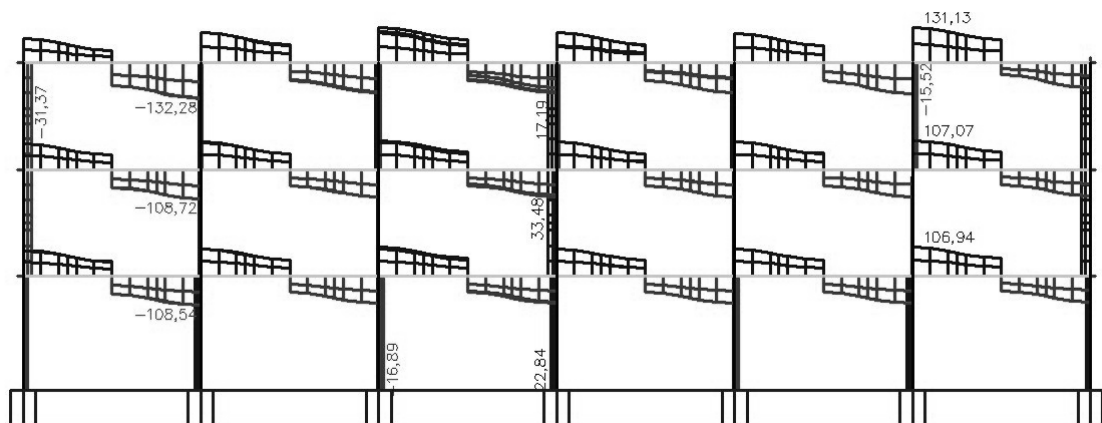



Upogibni moment  $M_y$  [kNm] za MSN

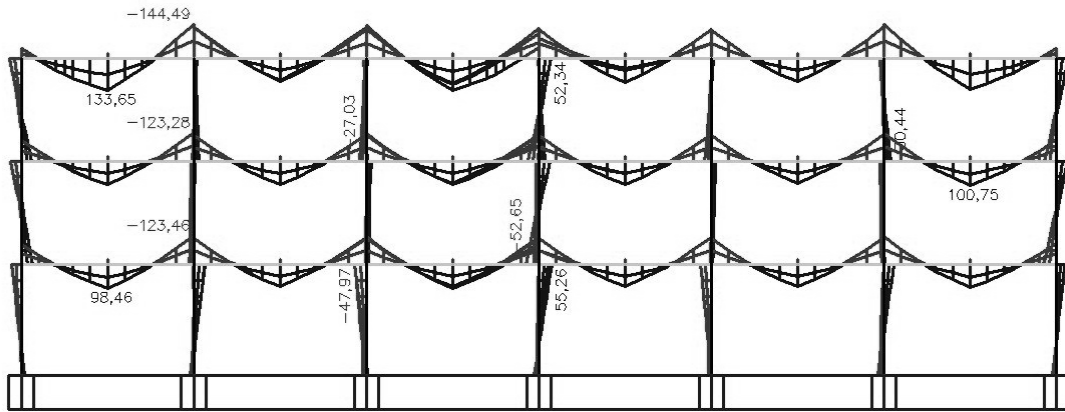

Oсна sila  $N$  [kN] za potresno obtežno kombinacijo

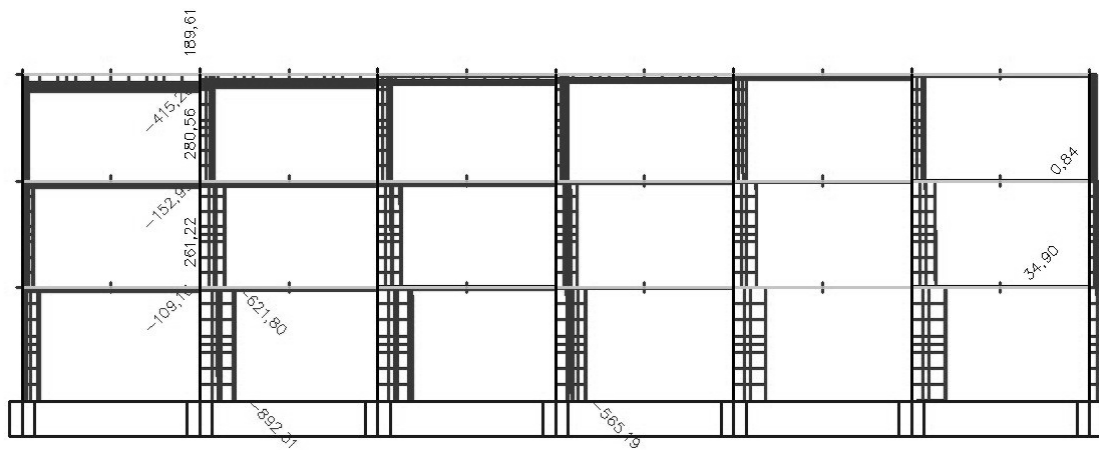

Prečna sila Vz [kN] za potresno obtežno kombinacijo

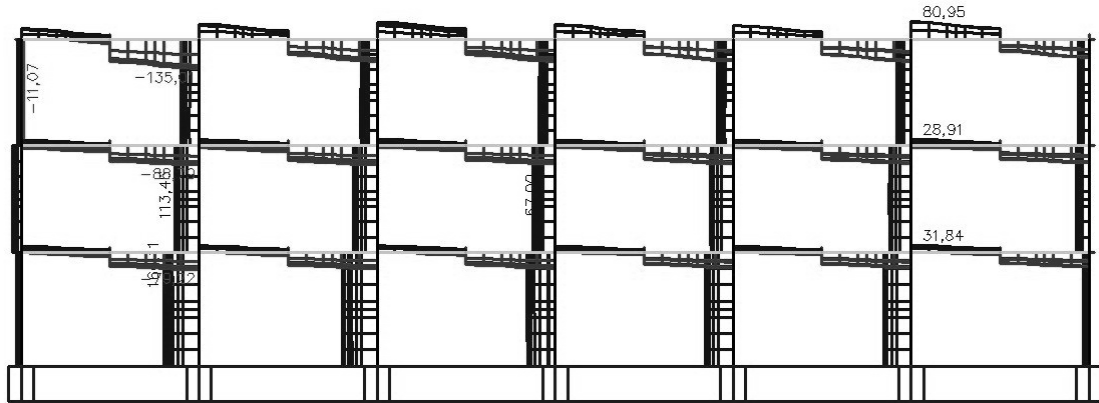

Upogibni moment My [kNm] za potresno obtežno kombinacijo

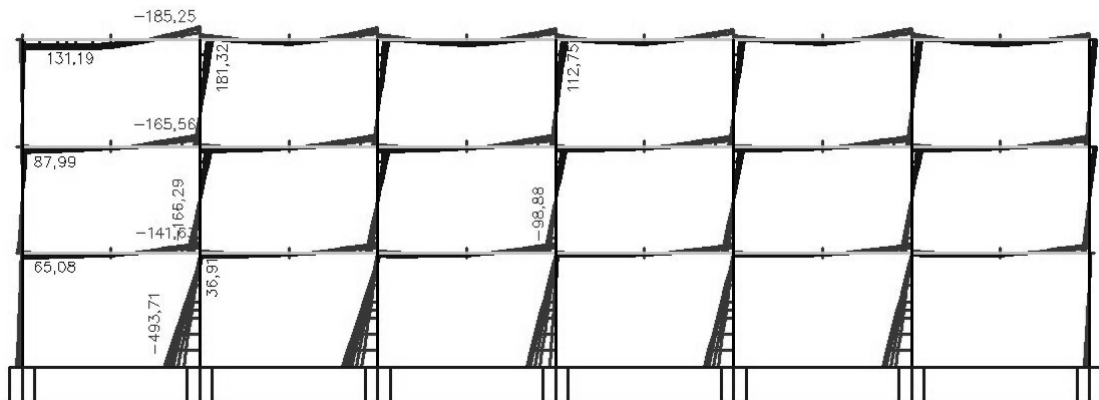

Oсна sila N [kN] za potresno obtežno kombinacijo

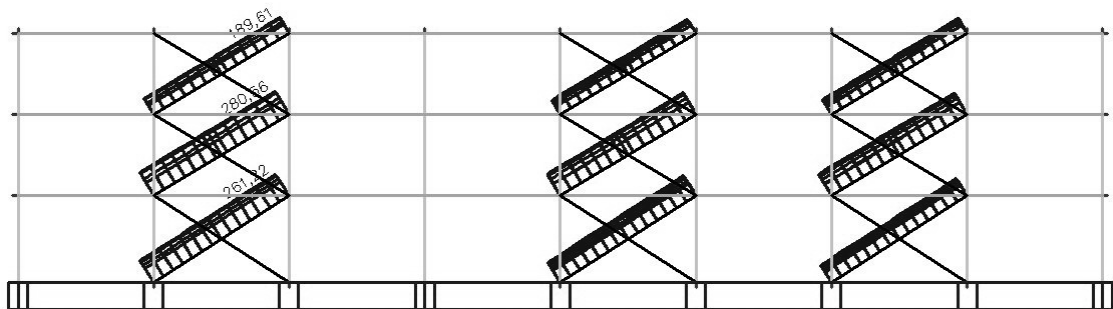

Osna sila N [kN] za gravitacijsko obtežbo

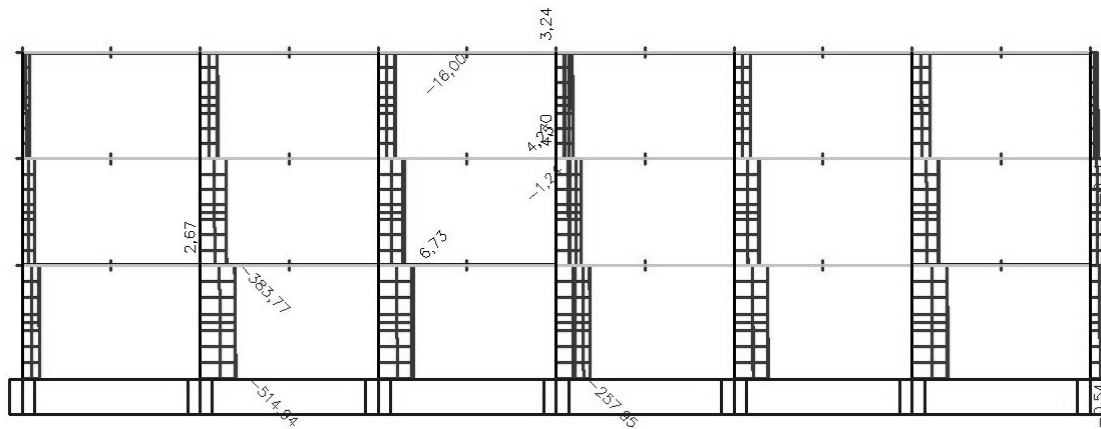

Prečna sila Vz [kN] za gravitacijsko obtežbo

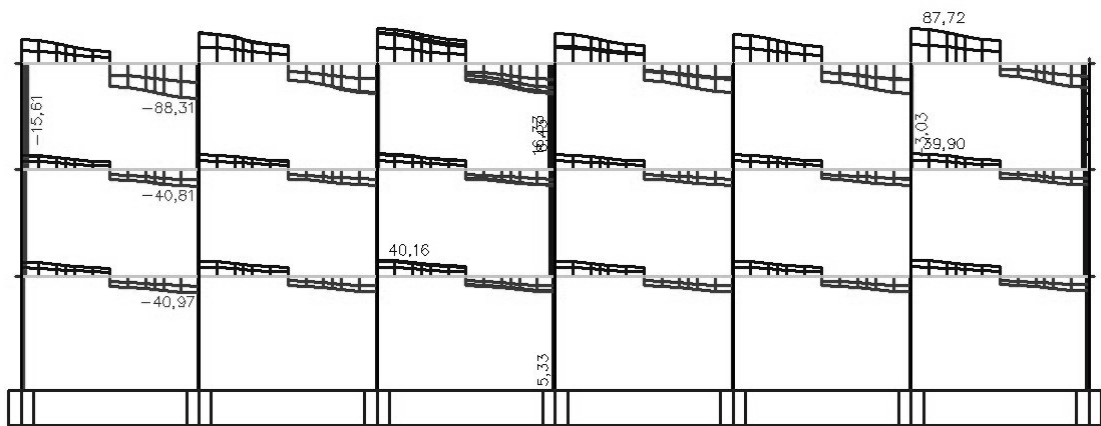

Upogibni moment My [kNm] za gravitacijsko obtežbo

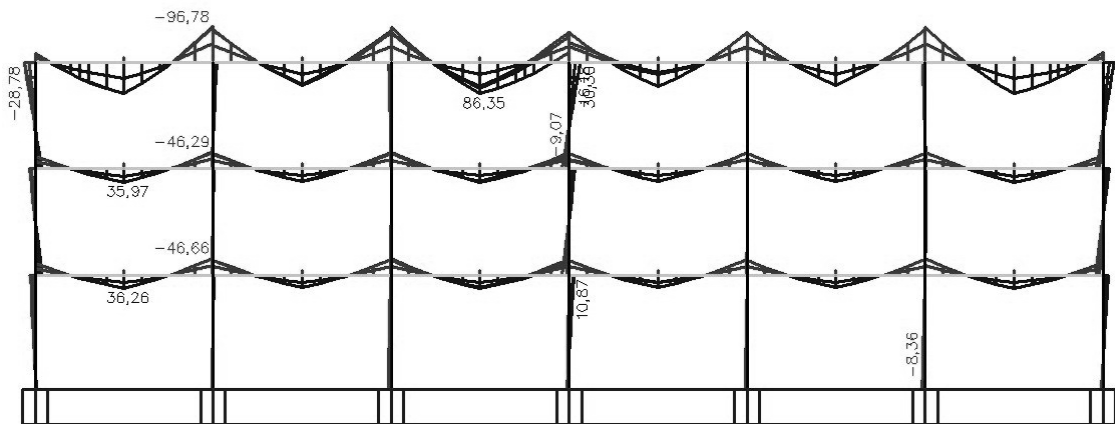

Osna sila N [kN] za potresno obtežbo

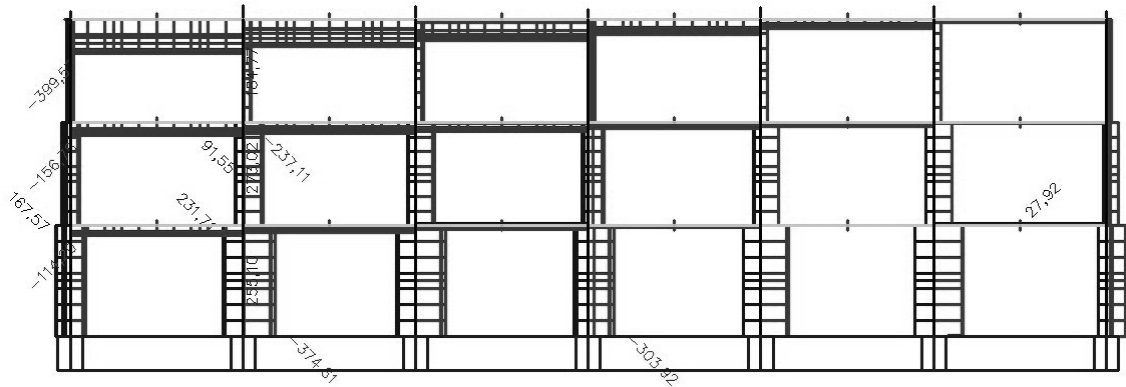

Prečna sila Vz [kN] za potresno obtežbo

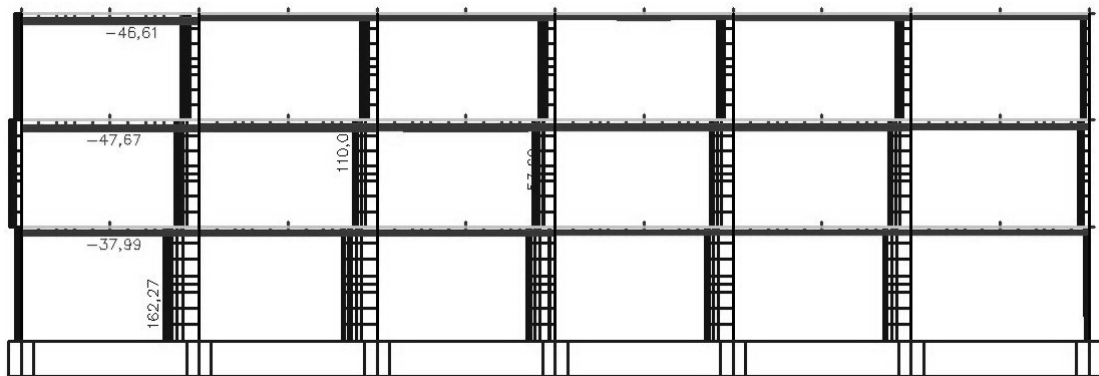

Upogibni moment My [kNm] za potresno obtežbo

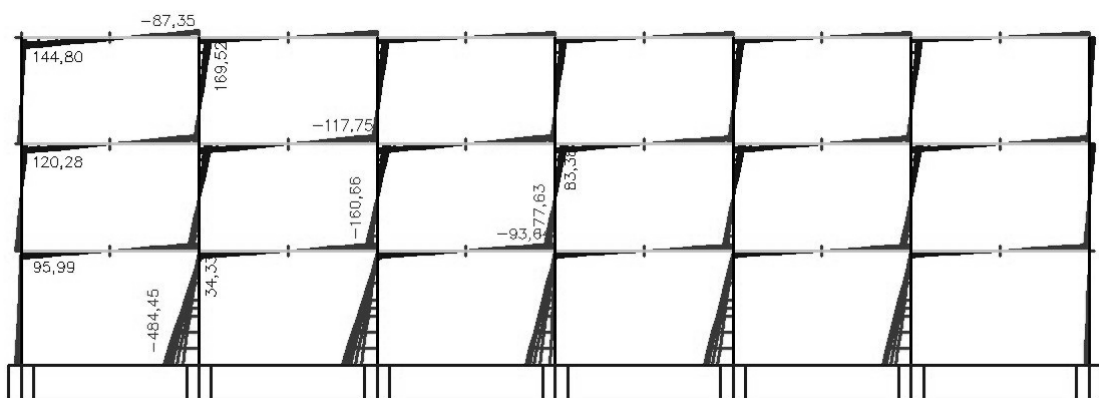

Pomik stebrov  $u_x$  [mm] za MSU

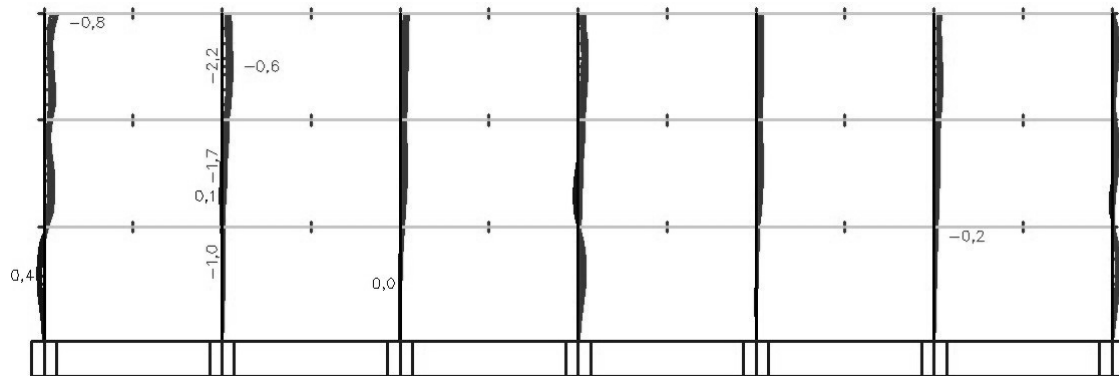

Pomik stebrov  $u_x$  [mm] za potresno obtežno kombinacijo

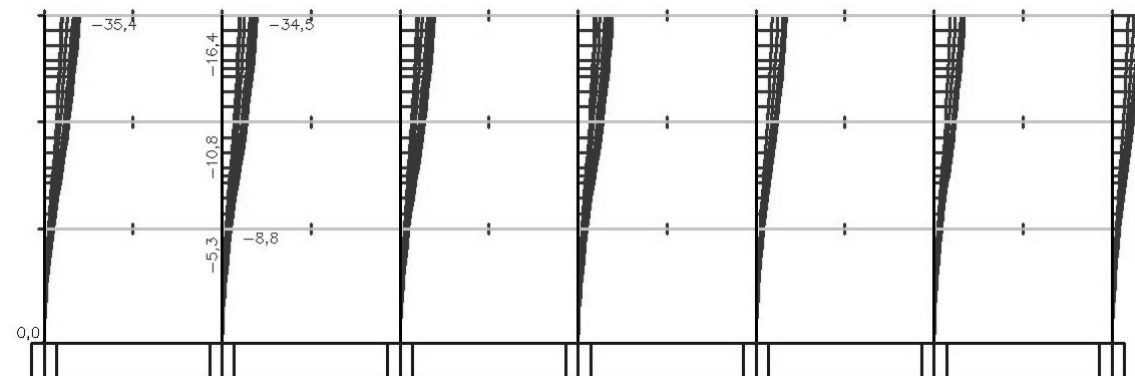

Pomik stebrov  $u_y$  [mm] za MSU

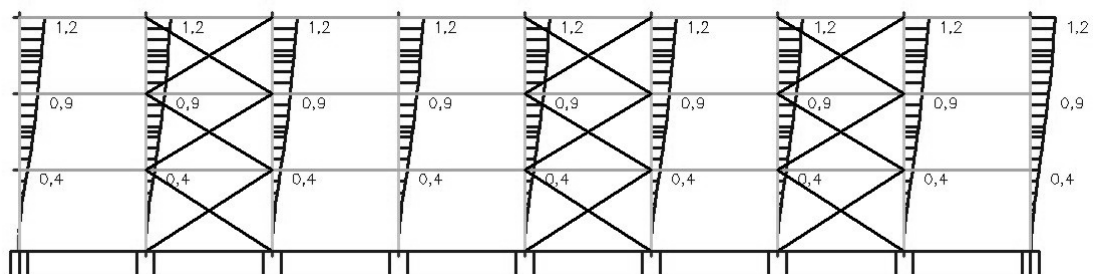

### Pomik stebrov $u_y$ [mm] za potresno obtežno kombinacijo

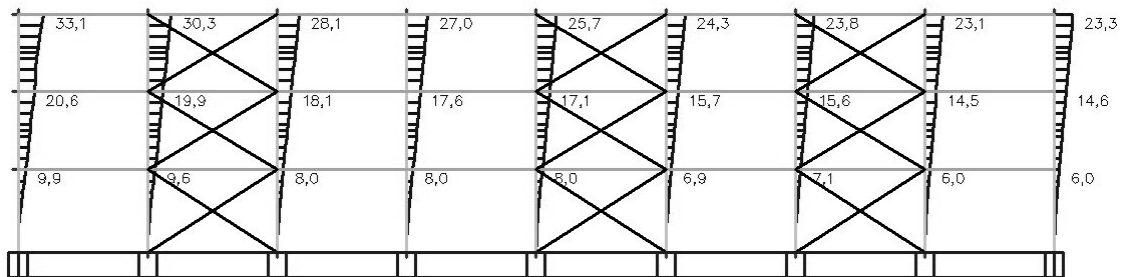

### Pomik prečk uz [mm] za MSU

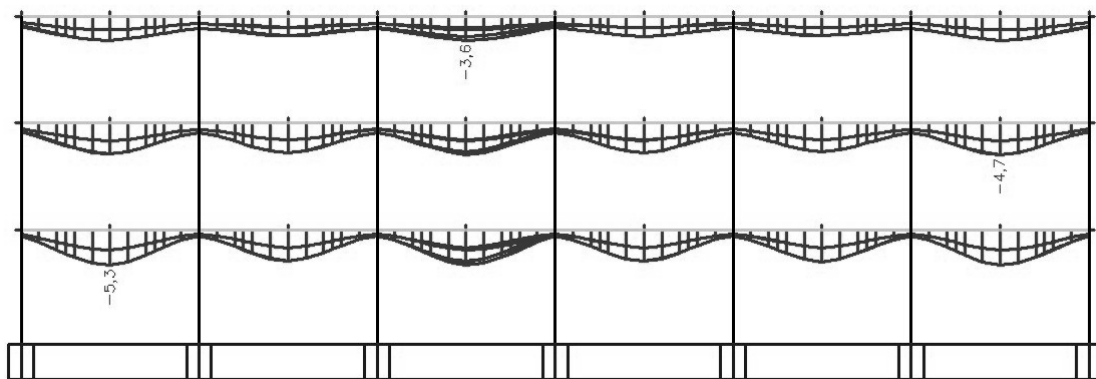

### Pomik prečk uz [mm] zaradi koristne obtežbe

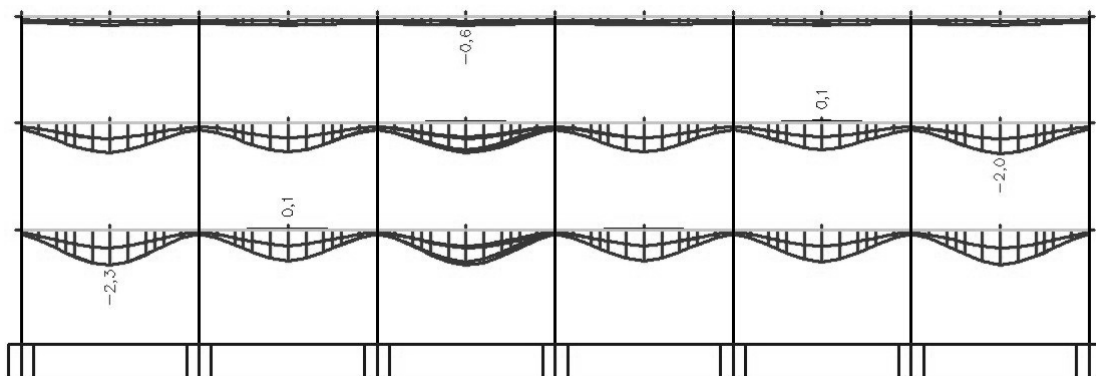

### Kontrola nosilnosti stebrov

Nonlinear calculation, Extreme : Cross-section  
 Selection : All  
 Class : Potres  
 Layer : steber

#### EN 1993-1-1 Code Check

Member B41	HEA280	S 235	NC10	0.52
------------	--------	-------	------	------

Basic data EC3 : EN 1993			
partial safety factor	Gamma M0 for resistance of cross-sections		1.00
partial safety factor	Gamma M1 for resistance to instability		1.00
partial safety factor	Gamma M2 for resistance of net sections		1.25

Material data		
yield strength fy	235.0	MP a
tension strength fu	360.0	MP a
fabrication	rolled	

.....SECTION CHECK:.....

Width-to-thickness ratio for internal compression parts (EN 1993-1-1 : Tab.5.2. sheet 1).  
 ratio 24.50 on position 0.000 m

ratio		
maximum ratio	1	40.97
maximum ratio	2	47.18
maximum ratio	3	82.58

==> Class cross-section 1

Width-to-thickness ratio for outstand flanges (EN 1993-1-1 : Tab.5.2. sheet 2).  
 ratio 8.62 on position 0.000 m

ratio		
maximum ratio	1	9.00
maximum ratio	2	10.00
maximum ratio	3	13.93

==> Class cross-section 1

**The critical check is on position 0.000 m**

Internal forces		
NEd	-236.15	kN
Vy,Ed	3.22	kN
Vz,Ed	66.42	kN
TEd	-0.14	kNm
My,Ed	-98.88	kNm
Mz,Ed	-5.88	kNm

Warning : The unity check for pure torsion is 0.02 for Non-Lin. Comb. 10.

**Compression check**

According to article EN 1993-1-1 : 6.2.4 and formula (6.9)

Section classification is 1.

Table of values		
Nc,Rd	2286.55	kN
Unity check	0.10	-

**Torsion check**

According to article EN 1993-1-1 : 6.2.7. and formula (6.23)

Table of values		
tau t,Rd	136.3	MP a
tau t, Ed	3.0	MP a
Unity check	0.02	-

**Shear check (Vy)**

According to article EN 1993-1-1 : 6.2.6. & 6.2.7 and formula (6.25)

Table of values		
Vc,Rd	1046.12	kN

Table of values		
*Student version* *Student version* *Student version*		
Unity check	0.00	-

#### Shear check (Vz)

According to article EN 1993-1-1 : 6.2.6. & 6.2.7 and formula (6.25)

Table of values		
*Student version* *Student version* *Student version*		
Vc,Rd	427.43	kN
Unity check	0.16	-

#### Bending moment check (My)

According to article EN 1993-1-1 : 6.2.5. and formula (6.12)  
Section classification is 1.

Table of values		
*Student version* *Student version* *Student version*		
Mc,Rd	261.32	kNm
Unity check	0.38	-

#### Bending moment check (Mz)

According to article EN 1993-1-1 : 6.2.5. and formula (6.12)  
Section classification is 1.

Table of values		
*Student version* *Student version* *Student version*		
Mc,Rd	121.73	kNm
Unity check	0.05	-

#### Combined bending, axial force and shear force check

According to article EN 1993-1-1 : 6.2.9.1. and formula (6.41)  
Section classification is 1.

Table of values		
*Student version* *Student version* *Student version*		
MNVy,Rd	261.32	kNm
MNVz,Rd	121.73	kNm

alfa 2.00 beta 1.00  
Unity check 0.19 -

Element satisfies the section check !

....:STABILITY CHECK:....

#### Flexural Buckling Check

According to article EN 1993-1-1 : 6.3.1.1. and formula (6.46)

Buckling parameters	yy	zz	
*Student version* *Student version* *Student version* *Student version* *Student version*			
Sway type	sway	non-sway	
System Length L	3.000	3.000	m
Buckling factor k	1.00	0.50	
Buckling length Lcr	3.000	1.500	m
Critical Euler load Ncr	31549.84	43847.36	kN
Slenderness	25.28	21.45	
Relative slenderness Lambda	0.27	0.23	
Limit slenderness Lambda,0	0.20	0.20	

The slenderness or compression force is such that Flexural Buckling effects may be ignored according to EN 1993-1-1 article 6.3.1.2(4)

#### Lateral Torsional Buckling Check

According to article EN 1993-1-1 : 6.3.2.1. and formula (6.54)

LTB Parameters		
*Student version* *Student version* *Student version* *Student version* *Student version*		
Method for LTB curve	Art. 6.3.2.2.	
Wy	1.1120e-03	m <sup>3</sup>
Elastic critical moment Mcr	15737.40	kNm
Relative slenderness Lambda,LT	0.13	
Limit slenderness Lambda,LT,0	0.40	

The slenderness or bending moment is such that Lateral Torsional Buckling effects may be ignored according to EN 1993-1-1 article 6.3.2.2(4)



### Compression and bending check

According to article EN 1993-1-1 : 6.3.3. and formula (6.61), (6.62)  
Interaction Method 1

Table of values		
kyy	0.994	
kyz	0.650	
kzy	0.515	
kzz	0.987	
Delta My	0.00	kNm
Delta Mz	0.00	kNm
A	9.7300e-03	m <sup>2</sup>
Wy	1.1120e-03	m <sup>3</sup>
Wz	5.1800e-04	m <sup>3</sup>
NRk	2286.55	kN
My,Rk	261.32	kNm
Mz,Rk	121.73	kNm
My,Ed	101.82	kNm
Mz,Ed	-5.88	kNm
Interaction Method 1		
Mcr0	5831.93	kNm
reduced slenderness 0	0.21	
Cmy,0	0.994	
Cmz,0	0.996	
Cmy	0.998	
Cmz	0.996	
CmLT	1.004	
muy	1.000	
muz	1.000	
wy	1.101	
wz	1.500	
npI	0.103	
aLT	0.995	
bLT	0.000	
cLT	0.035	
dLT	0.078	
eLT	1.362	
Cyy	1.016	
Cyz	1.079	
Czy	1.007	
Czz	1.014	

Unity check (6.61) = 0.10 + 0.39 + 0.03 = 0.52

Unity check (6.62) = 0.10 + 0.20 + 0.05 = 0.35

### Shear buckling check

in buckling field 1

According to article EN 1993-1-5 : 5. & 7.1. and formula (5.10) & (7.1)

Table of values	
hw/t	30.500

The web slenderness is such that the Shear Buckling Check is not required.

Element satisfies the stability check !

\*Student version\* \*Student version\* \*Student version\* \*Student version\* \*Student version\* \*Student version\* \*Student version\* \*Student version\* \*Student version\* \*Student version\*

### EN 1993-1-1 Code Check

Member B55	HEB500	S 235	NC10	0.56
------------	--------	-------	------	------

Basic data EC3 : EN 1993			
partial safety factor Gamma M0 for resistance of cross-sections			1.00
partial safety factor Gamma M1 for resistance to instability			1.00
partial safety factor Gamma M2 for resistance of net sections			1.25

Material data		
yield strength fy	235.0	MP a
tension strength fu	360.0	MP a
fabrication	rolled	

.....SECTION CHECK:.....

Width-to-thickness ratio for internal compression parts (EN 1993-1-1 : Tab.5.2. sheet 1).  
 ratio 26.90 on position 0.000 m

ratio		
*Student version* *Student version* *Student version*		
maximum ratio	1	45.95
maximum ratio	2	52.92
maximum ratio	3	84.13

==> Class cross-section 1  
 Width-to-thickness ratio for outstand flanges (EN 1993-1-1 : Tab.5.2. sheet 2).  
 ratio 4.13 on position 0.000 m

ratio		
*Student version* *Student version* *Student version*		
maximum ratio	1	9.00
maximum ratio	2	10.00
maximum ratio	3	13.98

==> Class cross-section 1  
**The critical check is on position 0.000 m**

Internal forces		
*Student version* *Student version* *Student version*		
NEd	-637.37	kN
Vy,Ed	-8.83	kN
Vz,Ed	153.58	kN
TEd	0.01	kNm
My,Ed	-461.77	kNm
Mz,Ed	23.06	kNm

Warning: Torsion is not taken into account for this cross-section!

### Compression check

According to article EN 1993-1-1 : 6.2.4 and formula (6.9)  
 Section classification is 1.

Table of values		
*Student version* *Student version* *Student version*		
Nc,Rd	5607.10	kN
Unity check	0.11	-

### Shear check (Vy)

According to article EN 1993-1-1 : 6.2.6. and formula (6.17)

Table of values		
*Student version* *Student version* *Student version*		
Vc,Rd	2363.77	kN
Unity check	0.00	-

### Shear check (Vz)

According to article EN 1993-1-1 : 6.2.6. and formula (6.17)

Table of values		
*Student version* *Student version* *Student version*		
Vc,Rd	1218.11	kN
Unity check	0.13	-

### Bending moment check (My)

According to article EN 1993-1-1 : 6.2.5. and formula (6.12)  
 Section classification is 1.

Table of values		
*Student version* *Student version* *Student version*		
Mc,Rd	1132.70	kNm
Unity check	0.41	-

### Bending moment check (Mz)

According to article EN 1993-1-1 : 6.2.5. and formula (6.12)  
 Section classification is 1.

Table of values		
*Student version* *Student version* *Student version*		
Mc,Rd	303.15	kNm
Unity check	0.08	-

### Combined bending, axial force and shear force check

According to article EN 1993-1-1 : 6.2.9.1. and formula (6.41)  
Section classification is 1.

Table of values		
*Student version* *Student version* *Student version*		
MNVy,Rd	1132.70	kNm
MNVz,Rd	303.15	kNm

alfa 2.00 beta 1.00  
Unity check 0.24 -

Element satisfies the section check !

....:STABILITY CHECK:....

### Flexural Buckling Check

According to article EN 1993-1-1 : 6.3.1.1. and formula (6.46)

Buckling parameters	yy	zz	
*Student version* *Student version* *Student version* *Student version*			
Sway type	sway	non-sway	
System Length L	3.200	3.200	m
Buckling factor k	1.00	0.50	
Buckling length Lcr	3.200	1.600	m
Critical Euler load Ncr	216977.08	102173.54	kN
Slenderness	15.10	22.00	
Relative slenderness Lambda	0.16	0.23	
Limit slenderness Lambda,0	0.20	0.20	

The slenderness or compression force is such that Flexural Buckling effects may be ignored according to EN 1993-1-1 article 6.3.1.2(4)

### Lateral Torsional Buckling Check

According to article EN 1993-1-1 : 6.3.2.1. and formula (6.54)

LTB Parameters		
*Student version* *Student version* *Student version* *Student version* *S		
Method for LTB curve	Art. 6.3.2.2.	
Wy	4.8200e-03	m <sup>3</sup>
Elastic critical moment Mcr	49830.18	kNm
Relative slenderness Lambda,LT	0.15	
Limit slenderness Lambda,LT,0	0.40	

The slenderness or bending moment is such that Lateral Torsional Buckling effects may be ignored according to EN 1993-1-1 article 6.3.2.2(4)

### Compression and bending check

According to article EN 1993-1-1 : 6.3.3. and formula (6.61), (6.62)  
Interaction Method 1

Table of values		
*Student version* *Student version* *Student version* *Student version*		
kyy	0.986	
kyz	0.638	
kzy	0.521	
kzz	0.988	
Delta My	0.00	kNm
Delta Mz	0.00	kNm
A	2.3860e-02	m <sup>2</sup>
Wy	4.8200e-03	m <sup>3</sup>
Wz	1.2900e-03	m <sup>3</sup>
NRk	5607.10	kN
My,Rk	1132.70	kNm
Mz,Rk	303.15	kNm
My,Ed	-461.77	kNm
Mz,Ed	23.06	kNm
Interaction Method 1		
Mcr0	25088.30	kNm
reduced slenderness 0	0.21	
Cmy,0	0.999	
Cmz,0	0.997	
Cmy	1.000	
Cmz	0.997	
*Student version* *Student version* *Student version* *Student version*		

Table of values	
CmLT	1.006
muy	1.000
muz	1.000
wy	1.124
wz	1.500
np1	0.114
aLT	0.995
bLT	0.001
cLT	0.037
dLT	0.128
eLT	1.423
Cyy	1.022
Cyz	1.090
Czy	1.006
Czz	1.015

Unity check (6.61) = 0.11 + 0.40 + 0.05 = 0.56

Unity check (6.62) = 0.11 + 0.21 + 0.08 = 0.40

### Shear buckling check

in buckling field 1

According to article EN 1993-1-5 : 5. & 7.1. and formula (5.10) & (7.1)

Table of values	
hw/t	30.621

The web slenderness is such that the Shear Buckling Check is not required.

Element satisfies the stability check !

\*Student version\* \*Student version\* \*Student version\* \*Student version\* \*Student version\* \*Student version\* \*Student version\* \*Student version\* \*Student version\* \*Student version\*

### EN 1993-1-1 Code Check

Member B35	HEA340	S 235	NC10	0.54
------------	--------	-------	------	------

Basic data EC3 : EN 1993	
partial safety factor Gamma M0 for resistance of cross-sections	1.00
partial safety factor Gamma M1 for resistance to instability	1.00
partial safety factor Gamma M2 for resistance of net sections	1.25

Material data	
yield strength fy	235.0 MP a
tension strength fu	360.0 MP a
fabrication	rolled

### .....SECTION CHECK:.....

Width-to-thickness ratio for internal compression parts (EN 1993-1-1 : Tab.5.2. sheet 1).

ratio 25.58 on position 0.000 m

ratio	
maximum ratio 1	40.44
maximum ratio 2	46.57
maximum ratio 3	81.24

==> Class cross-section 1

Width-to-thickness ratio for outstand flanges (EN 1993-1-1 : Tab.5.2. sheet 2).

ratio 7.17 on position 0.000 m

ratio	
maximum ratio 1	9.00
maximum ratio 2	10.00
maximum ratio 3	13.91

==> Class cross-section 1

**The critical check is on position 0.000 m**

Internal forces		
*Student version* *Student version* *Student version*		
N <sub>y,Ed</sub>	4338.18	kN
V <sub>z,Ed</sub>	112.72	kN
T <sub>Ed</sub>	-0.27	kNm
M <sub>y,Ed</sub>	-166.29	kNm
M <sub>z,Ed</sub>	-7.78	kNm

Warning : The unity check for pure torsion is 0.03 for Non-Linear. Comb. 10.

#### Compression check

According to article EN 1993-1-1 : 6.2.4 and formula (6.9)

Section classification is 1.

Table of values		
*Student version* *Student version* *Student version*		
N <sub>c,Rd</sub>	3149.00	kN
Unity check	0.11	-

#### Torsion check

According to article EN 1993-1-1 : 6.2.7. and formula (6.23)

Table of values		
*Student version* *Student version* *Student version*		
tau <sub>t,Rd</sub>	136.3	MPa
tau <sub>t, Ed</sub>	3.5	MPa
Unity check	0.03	-

#### Shear check (V<sub>y</sub>)

According to article EN 1993-1-1 : 6.2.6. & 6.2.7 and formula (6.25)

Table of values		
*Student version* *Student version* *Student version*		
V <sub>c,Rd</sub>	1420.25	kN
Unity check	0.00	-

#### Shear check (V<sub>z</sub>)

According to article EN 1993-1-1 : 6.2.6. & 6.2.7 and formula (6.25)

Table of values		
*Student version* *Student version* *Student version*		
V <sub>c,Rd</sub>	610.57	kN
Unity check	0.18	-

#### Bending moment check (M<sub>y</sub>)

According to article EN 1993-1-1 : 6.2.5. and formula (6.12)

Section classification is 1.

Table of values		
*Student version* *Student version* *Student version*		
M <sub>c,Rd</sub>	434.75	kNm
Unity check	0.38	-

#### Bending moment check (M<sub>z</sub>)

According to article EN 1993-1-1 : 6.2.5. and formula (6.12)

Section classification is 1.

Table of values		
*Student version* *Student version* *Student version*		
M <sub>c,Rd</sub>	177.66	kNm
Unity check	0.04	-

#### Combined bending, axial force and shear force check

According to article EN 1993-1-1 : 6.2.9.1. and formula (6.41)

Section classification is 1.

Table of values		
MNVy.Rd	434.75	kNm
MNVz.Rd	177.66	kNm

alfa 2.00 beta 1.00  
 Unity check 0.19 -

Element satisfies the section check !

....:STABILITY CHECK:....

**Flexural Buckling Check**

According to article EN 1993-1-1 : 6.3.1.1. and formula (6.46)

Buckling parameters	yy	zz	
Sway type	sway	non-sway	
System Length L	3.000	3.000	m
Buckling factor k	1.00	0.50	
Buckling length Lcr	3.000	1.500	m
Critical Euler load Ncr	63790.54	68534.53	kN
Slenderness	20.87	20.13	
Relative slenderness Lambda	0.22	0.21	
Limit slenderness Lambda,0	0.20	0.20	

The slenderness or compression force is such that Flexural Buckling effects may be ignored according to EN 1993-1-1 article 6.3.1.2(4)

**Lateral Torsional Buckling Check**

According to article EN 1993-1-1 : 6.3.2.1. and formula (6.54)

LTB Parameters		
Method for LTB curve	Art. 6.3.2.2.	
Wy	1.8500e-03	m <sup>3</sup>
Elastic critical moment Mer	29882.19	kNm
Relative slenderness Lambda,LT	0.12	
Limit slenderness Lambda,LT,0	0.40	

The slenderness or bending moment is such that Lateral Torsional Buckling effects may be ignored according to EN 1993-1-1 article 6.3.2.2(4)

**Compression and bending check**

According to article EN 1993-1-1 : 6.3.3. and formula (6.61), (6.62)

Interaction Method 1

Table of values		
kyy	0.990	
kyz	0.642	
kzy	0.512	
kzz	0.979	
Delta My	0.00	kNm
Delta Mz	0.00	kNm
A	1.3400e-02	m <sup>2</sup>
Wy	1.8500e-03	m <sup>3</sup>
Wz	7.5600e-04	m <sup>3</sup>
NRk	3149.00	kN
My,Rk	434.75	kNm
Mz,Rk	177.66	kNm
My,Ed	173.84	kNm
Mz,Ed	-7.78	kNm
Interaction Method 1		
Mer0	11072.20	kNm
reduced slenderness 0	0.20	
Cmy,0	0.995	
Cnz,0	0.996	
Cmy	0.998	
Cmz	0.996	
CmLT	1.004	
muy	1.000	
muz	1.000	
wy	1.101	
wz	1.500	
npl	0.114	
aLT	0.995	
bLT	0.000	
cLT	0.031	
dLT	0.068	
eLT	1.315	

Table of values		
Cyy	1.018	
Cyz	1.093	
Czy	1.011	
Czz	1.023	

Unity check (6.61) = 0.11 + 0.40 + 0.03 = 0.54

Unity check (6.62) = 0.11 + 0.20 + 0.04 = 0.36

### Shear buckling check

in buckling field 1

According to article EN 1993-1-5 : 5. & 7.1. and formula (5.10) & (7.1)

Table of values	
hw/t	31.263

The web slenderness is such that the Shear Buckling Check is not required.  
Element satisfies the stability check !

## Kontrola nosilnosti primarnih prečk

Nonlinear calculation, Extreme : Cross-section

Selection : All

Class : Potres

Layer : prečke

### EN 1993-1-1 Code Check

Member B22	IPE330	S 235	NC10	0.83
------------	--------	-------	------	------

Basic data EC3 : EN 1993			
partial safety factor Gamma M0 for resistance of cross-sections			1.00
partial safety factor Gamma M1 for resistance to instability			1.00
partial safety factor Gamma M2 for resistance of net sections			1.25

Material data		
yield strength fy	235.0	MP a
tension strength fu	360.0	MP a
fabrication	rolled	

### .....SECTION CHECK:.....

Width-to-thickness ratio for internal compression parts (EN 1993-1-1 : Tab.5.2. sheet 1).

ratio 36.13 on position 3.000 m

ratio		
maximum ratio 1		33.00
maximum ratio 2		38.00
maximum ratio 3		55.17

==> Class cross-section 2

Width-to-thickness ratio for outstand flanges (EN 1993-1-1 : Tab.5.2. sheet 2).

ratio 5.07 on position 2.500 m

ratio		
maximum ratio 1		9.00
maximum ratio 2		10.00
maximum ratio 3		13.82

==> Class cross-section 1

**The critical check is on position 5.000 m**

Internal forces		
*Student version* *Student version* *Student version*		
N <sub>y,Ed</sub>	-69.09	kN
V <sub>z,Ed</sub>	-79.22	kN
T <sub>Ed</sub>	0.03	kNm
M <sub>y,Ed</sub>	-141.63	kNm
M <sub>z,Ed</sub>	-0.78	kNm

Warning: Torsion is not taken into account for this cross-section!

### Compression check

According to article EN 1993-1-1 : 6.2.4 and formula (6.9)  
Section classification is 1.

Table of values		
*Student version* *Student version* *Student version*		
N <sub>c,Rd</sub>	1471.10	kN
Unity check	0.05	-

### Shear check (V<sub>y</sub>)

According to article EN 1993-1-1 : 6.2.6. and formula (6.17)

Table of values		
*Student version* *Student version* *Student version*		
V <sub>c,Rd</sub>	536.94	kN
Unity check	0.00	-

### Shear check (V<sub>z</sub>)

According to article EN 1993-1-1 : 6.2.6. and formula (6.17)

Table of values		
*Student version* *Student version* *Student version*		
V <sub>c,Rd</sub>	417.92	kN
Unity check	0.19	-

### Bending moment check (M<sub>y</sub>)

According to article EN 1993-1-1 : 6.2.5. and formula (6.12)  
Section classification is 1.

Table of values		
*Student version* *Student version* *Student version*		
M <sub>c,Rd</sub>	189.01	kNm
Unity check	0.75	-

### Bending moment check (M<sub>z</sub>)

According to article EN 1993-1-1 : 6.2.5. and formula (6.12)  
Section classification is 1.

Table of values		
*Student version* *Student version* *Student version*		
M <sub>c,Rd</sub>	36.12	kNm
Unity check	0.02	-

### Combined bending, axial force and shear force check

According to article EN 1993-1-1 : 6.2.9.1. and formula (6.41)  
Section classification is 1.

Table of values		
*Student version* *Student version* *Student version*		
MNV <sub>y,Rd</sub>	189.01	kNm
MNV <sub>z,Rd</sub>	36.12	kNm

alfa 2.00 beta 1.00  
Unity check 0.58 -

Element satisfies the section check !

....:STABILITY CHECK:....

### Flexural Buckling Check

According to article EN 1993-1-1 : 6.3.1.1. and formula (6.46)



<b>Buckling parameters</b>	yy	zz	
*Student version* *Student version* *Student version* *Student version*			
Sway type	sway	non-sway	
System Length L	2.500	2.500	m
Buckling factor k	1.00	1.00	
Buckling length Lcr	2.500	2.500	m
Critical Euler load Ncr	39031.52	2613.49	kN
Slenderness	18.23	70.46	
Relative slenderness Lambda	0.19	0.75	
Limit slenderness Lambda,0	0.20	0.20	

The slenderness or compression force is such that Flexural Buckling effects may be ignored according to EN 1993-1-1 article 6.3.1.2(4)

### Lateral Torsional Buckling Check

According to article EN 1993-1-1 : 6.3.2.1. and formula (6.54)

<b>LTB Parameters</b>		
*Student version* *Student version* *Student version* *Student version*		
Method for LTB curve	Art. 6.3.2.2.	
Wy	8.0430e-04	m <sup>3</sup>
Elastic critical moment Mcr	1078.92	kNm
Relative slenderness Lambda,LT	0.42	
Limit slenderness Lambda,LT,0	0.40	

The slenderness or bending moment is such that Lateral Torsional Buckling effects may be ignored according to EN 1993-1-1 article 6.3.2.2(4)

### Compression and bending check

According to article EN 1993-1-1 : 6.3.3. and formula (6.61), (6.62)

Interaction Method 1

<b>Table of values</b>		
*Student version* *Student version* *Student version* *Student version*		
kyy	1.020	
kyz	0.940	
kzy	0.542	
kzz	1.047	
Delta My	0.00	kNm
Delta Mz	0.00	kNm
A	6.2600e-03	m <sup>2</sup>
Wy	8.0430e-04	m <sup>3</sup>
Wz	1.5370e-04	m <sup>3</sup>
NRk	1471.10	kN
My,Rk	189.01	kNm
Mz,Rk	36.12	kNm
My,Ed	-141.63	kNm
Mz,Ed	-0.78	kNm
Interaction Method 1		
Mcr0	481.62	kNm
reduced slenderness 0	0.63	
Cmy,0	0.999	
Cmz,0	0.989	
Cmy	1.000	
Cmz	0.989	
CmLT	1.019	
muy	1.000	
muz	1.000	
wy	1.128	
wz	1.500	
npI	0.047	
aLT	0.998	
bLT	0.003	
cLT	0.552	
dLT	0.049	
eLT	1.910	
Cyy	1.000	
Cyz	0.747	
Czy	0.980	
Czz	0.970	

Unity check (6.61) = 0.05 + 0.76 + 0.02 = 0.83

Unity check (6.62) = 0.05 + 0.41 + 0.02 = 0.48

### Shear buckling check

in buckling field 1

According to article EN 1993-1-5 : 5. & 7.1. and formula (5.10) & (7.1)

Table of values	
hw/t	40.933

The web slenderness is such that the Shear Buckling Check is not required.  
Element satisfies the stability check !

#### EN 1993-1-1 Code Check

Member B226	IPE360	S 235	NC10	0.80
-------------	--------	-------	------	------

Basic data EC3 : EN 1993				
partial safety factor	Gamma M0 for resistance of cross-sections			1.00
partial safety factor	Gamma M1 for resistance to instability			1.00
partial safety factor	Gamma M2 for resistance of net sections			1.25

Material data		
yield strength fy	235.0	MP a
tension strength fu	360.0	MP a
fabrication	rolled	

#### .....SECTION CHECK:.....

Width-to-thickness ratio for internal compression parts (EN 1993-1-1 : Tab.5.2. sheet 1).  
ratio 37.33 on position 3.000 m

ratio		
maximum ratio	1	33.00
maximum ratio	2	38.00
maximum ratio	3	44.77

==> Class cross-section 2

Width-to-thickness ratio for outstand flanges (EN 1993-1-1 : Tab.5.2. sheet 2).  
ratio 4.96 on position 2.500 m

ratio		
maximum ratio	1	9.00
maximum ratio	2	10.00
maximum ratio	3	13.90

==> Class cross-section 1

**The critical check is on position 5,000 m**

Internal forces		
N <sub>Ed</sub>	-152.99	kN
V <sub>y,Ed</sub>	0.67	kN
V <sub>z,Ed</sub>	-86.25	kN
T <sub>Ed</sub>	-0.02	kNm
M <sub>y,Ed</sub>	-159.04	kNm
M <sub>z,Ed</sub>	0.62	kNm

Warning: Torsion is not taken into account for this cross-section!

#### Compression check

According to article EN 1993-1-1 : 6.2.4 and formula (6.9)  
Section classification is 1.

Table of values		
N <sub>c,Rd</sub>	1708.45	kN
Unity check	0.09	-

#### Shear check (V<sub>y</sub>)

According to article EN 1993-1-1 : 6.2.6. and formula (6.17)

Table of values		
*Student version* *Student version* *Student version*		
Vc,Rd	623.19	kN
Unity check	0.00	-

#### Shear check (Vz)

According to article EN 1993-1-1 : 6.2.6. and formula (6.17)

Table of values		
*Student version* *Student version* *Student version*		
Vc,Rd	476.34	kN
Unity check	0.18	-

#### Bending moment check (My)

According to article EN 1993-1-1 : 6.2.5. and formula (6.12)  
Section classification is 1.

Table of values		
*Student version* *Student version* *Student version*		
Mc,Rd	239.47	kNm
Unity check	0.66	-

#### Bending moment check (Mz)

According to article EN 1993-1-1 : 6.2.5. and formula (6.12)  
Section classification is 1.

Table of values		
*Student version* *Student version* *Student version*		
Mc,Rd	44.91	kNm
Unity check	0.01	-

#### Combined bending, axial force and shear force check

According to article EN 1993-1-1 : 6.2.9.1. and formula (6.41)  
Section classification is 1.

Table of values		
*Student version* *Student version* *Student version*		
MNVy,Rd	239.47	kNm
MNVz,Rd	44.91	kNm

alfa 2.00 beta 1.00  
Unity check 0.45 -

Element satisfies the section check !

#### ...:STABILITY CHECK:...:

#### Flexural Buckling Check

According to article EN 1993-1-1 : 6.3.1.1. and formula (6.46)

Buckling parameters	yy	zz	
*Student version* *Student version* *Student version*			
Sway type	sway	non-sway	
System Length L	2.500	2.500	m
Buckling factor k	1.00	1.00	
Buckling length Lcr	2.500	2.500	m
Critical Euler load Ncr	53954.36	3458.78	kN
Slenderness	16.71	66.00	
Relative slenderness Lambda	0.18	0.70	
Limit slenderness Lambda,0	0.20	0.20	
Buckling curve	a	b	
Imperfection Alpha	0.21	0.34	
Reduction factor Chi	1.00	0.78	
Buckling resistance Nb,Rd	1708.45	1336.21	kN

Table of values		
*Student version* *Student version* *Student version*		
A	7.2700e-03	m <sup>2</sup>
Buckling resistance Nb,Rd	1336.21	kN
Unity check	0.11	-

#### Lateral Torsional Buckling Check

According to article EN 1993-1-1 : 6.3.2.1. and formula (6.54)

LTB Parameters		
*Student version* *Student version* *Student version* *Student version* *S		
Method for LTB curve	Art. 6.3.2.2.	
Wy	1.0190e-03	m <sup>3</sup>
Elastic critical moment Mer	1502.36	kNm
Relative slenderness Lambda,LT	0.40	
Limit slenderness Lambda,LT,0	0.40	

The slenderness or bending moment is such that Lateral Torsional Buckling effects may be ignored according to EN 1993-1-1 article 6.3.2.2(4)

### Compression and bending check

According to article EN 1993-1-1 : 6.3.3. and formula (6.61), (6.62)  
Interaction Method 1

Table of values		
*Student version* *Student version* *Student version* *Student version*		
kyy	1.033	
kyz	0.848	
kzy	0.549	
kzz	1.060	
Delta My	0.00	kNm
Delta Mz	0.00	kNm
A	7.2700e-03	m <sup>2</sup>
Wy	1.0190e-03	m <sup>3</sup>
Wz	1.9110e-04	m <sup>3</sup>
NRk	1708.45	kN
My,Rk	239.47	kNm
Mz,Rk	44.91	kNm
My,Ed	-159.04	kNm
Mz,Ed	-1.10	kNm
Interaction Method 1		
Mcr0	681.12	kNm
reduced slenderness 0	0.59	
Cmy,0	0.998	
Cmz,0	0.971	
Cmy	1.000	
Cmz	0.971	
CmLT	1.034	
muy	1.000	
muz	0.990	
wy	1.128	
wz	1.500	
npI	0.090	
aLT	0.998	
bLT	0.003	
cLT	0.444	
dLT	0.058	
eLT	1.943	
Cyy	1.003	
Cyz	0.829	
Czy	0.972	
Czz	0.949	

Unity check (6.61) = 0.09 + 0.69 + 0.02 = 0.80

Unity check (6.62) = 0.11 + 0.36 + 0.03 = 0.51

### Shear buckling check

in buckling field 1

According to article EN 1993-1-5 : 5. & 7.1. and formula (5.10) & (7.1)

Table of values	
*Student version* *Student version* *Student version*	
hw/t	41.825

The web slenderness is such that the Shear Buckling Check is not required.

Element satisfies the stability check !

### EN 1993-1-1 Code Check

Member B232	IPE500	S 235	NC10	0.65
-------------	--------	-------	------	------

Basic data EC3 : EN 1993	
*Student version* *Student version* *Student version* *Student version* *Student version* *S	
partial safety factor Gamma M0 for resistance of cross-sections	1.00
partial safety factor Gamma M1 for resistance to instability	1.00
*Student version* *Student version* *Student version* *Student version* *Student version* *S	

Basic data EC3 : EN 1993	
partial safety factor $\gamma_{M2}$ for resistance of net sections	1.25

Material data		
yield strength $f_y$	235.0	MPa
tension strength $f_u$	360.0	MPa
fabrication	rolled	

Width-to-thickness ratio for internal compression parts (EN 1993-1-1 : Tab.5.2. sheet 1).  
 ratio 41.76 on position 3.000 m

ratio		
maximum ratio	1	33.00
maximum ratio	2	38.00
maximum ratio	3	58.94

==> Class cross-section 3  
 Width-to-thickness ratio for outstand flanges (EN 1993-1-1 : Tab.5.2. sheet 2).  
 ratio 4.62 on position 2.500 m

ratio		
maximum ratio	1	9.00
maximum ratio	2	10.00
maximum ratio	3	13.87

==> Class cross-section 1  
**The critical check is on position 5.000 m**

Internal forces		
N <sub>Ed</sub>	-415.26	kN
V <sub>y,Ed</sub>	1.08	kN
V <sub>z,Ed</sub>	-135.01	kN
T <sub>Ed</sub>	-0.11	kNm
M <sub>y,Ed</sub>	-185.25	kNm
M <sub>z,Ed</sub>	0.58	kNm

Warning : The unity check for pure torsion is 0.01 for Non-Lin. Comb. 10.

### Compression check

According to article EN 1993-1-1 : 6.2.4 and formula (6.9)  
 Section classification is 1.

Table of values		
N <sub>c,Rd</sub>	2726.00	kN
Unity check	0.15	-

### Torsion check

According to article EN 1993-1-1 : 6.2.7. and formula (6.23)

Table of values		
$\tau_{t,Rd}$	136.3	MPa
$\tau_{t,Ed}$	2.0	MPa
Unity check	0.01	-

### Shear check (V<sub>y</sub>)

According to article EN 1993-1-1 : 6.2.6. & 6.2.7 and formula (6.25)

Table of values		
V <sub>c,Rd</sub>	920.76	kN
Unity check	0.00	-

### Shear check (V<sub>z</sub>)

According to article EN 1993-1-1 : 6.2.6. & 6.2.7 and formula (6.25)

Table of values		
*Student version* *Student version* *Student version*		
Vc,Rd	814.04	kN
Unity check	0.17	-

#### Bending moment check (My)

According to article EN 1993-1-1 : 6.2.5. and formula (6.12)  
Section classification is 1.

Table of values		
*Student version* *Student version* *Student version*		
Mc,Rd	515.59	kNm
Unity check	0.36	-

#### Bending moment check (Mz)

According to article EN 1993-1-1 : 6.2.5. and formula (6.12)  
Section classification is 1.

Table of values		
*Student version* *Student version* *Student versio		
Mc,Rd	78.94	kNm
Unity check	0.01	-

#### Combined bending, axial force and shear force check

According to article EN 1993-1-1 : 6.2.9.1. and formula (6.41)  
Section classification is 1.

Table of values		
*Student version* *Student version* *Student version*		
MNVy,Rd	515.59	kNm
MNVz,Rd	78.94	kNm

alfa 2.00 beta 1.00  
Unity check 0.14 -

Element satisfies the section check !

....:STABILITY CHECK:....

#### Flexural Buckling Check

According to article EN 1993-1-1 : 6.3.1.1. and formula (6.46)

Buckling parameters	yy	zz	
*Student version* *Student version* *Student version* *Student version*			
Sway type	sway	non-sway	
System Length L	2.500	2.500	m
Buckling factor k	1.00	1.00	
Buckling length Lcr	2.500	2.500	m
Critical Euler load Ncr	159840.22	7103.27	kN
Slenderness	12.26	58.18	
Relative slenderness Lambda	0.13	0.62	
Limit slenderness Lambda,0	0.20	0.20	
Buckling curve	a	b	
Imperfection Alpha	0.21	0.34	
Reduction factor Chi	1.00	0.83	
Buckling resistance Nb,Rd	2726.00	2254.84	kN

Table of values		
*Student version* *Student version* *Student version* *Student ve		
A	1.1600e-02	m <sup>2</sup>
Buckling resistance Nb,Rd	2254.84	kN
Unity check	0.18	-

#### Lateral Torsional Buckling Check

According to article EN 1993-1-1 : 6.3.2.1. and formula (6.54)

LTB Parameters		
*Student version* *Student version* *Student version* *Student version* *S		
Method for LTB curve	Art. 6.3.2.2.	
Wy	1.9280e-03	m <sup>3</sup>
Elastic critical moment Mcr	4804.27	kNm
Relative slenderness Lambda,LT	0.31	
Limit slenderness Lambda,LT,0	0.40	

The slenderness or bending moment is such that Lateral Torsional Buckling effects may be ignored according to EN 1993-1-1 article 6.3.2.2(4)

### Compression and bending check

According to article EN 1993-1-1 : 6.3.3. and formula (6.61), (6.62)  
Interaction Method 1

Table of values		
kyy	1.049	
kyz	1.027	
kzy	1.037	
kzz	1.016	
Delta My	0.00	kNm
Delta Mz	0.00	kNm
A	1.1600e-02	m <sup>2</sup>
Wy	1.9280e-03	m <sup>3</sup>
Wz	2.1420e-04	m <sup>3</sup>
NRk	2726.00	kN
My,Rk	453.08	kNm
Mz,Rk	50.34	kNm
My,Ed	-185.25	kNm
Mz,Ed	-2.30	kNm
Interaction Method 1		
Mcr0	1858.52	kNm
reduced slenderness 0	0.49	
Cmy,0	0.998	
Cmz,0	0.967	
Cmy	0.999	
Cmz	0.967	
CmLT	1.047	
muy	1.000	
muz	0.989	
wy	1.138	
wz	1.500	
npI	0.152	
aLT	0.998	
bLT	0.001	
cLT	0.170	
dLT	0.043	
eLT	1.218	
Cyy	1.012	
Cyz	1.017	
Czy	0.977	
Czz	0.983	

Unity check (6.61) = 0.15 + 0.43 + 0.05 = 0.63

Unity check (6.62) = 0.18 + 0.42 + 0.05 = 0.65

### Shear buckling check

in buckling field 1

According to article EN 1993-1-5 : 5. & 7.1. and formula (5.10) & (7.1)

Table of values	
hw/t	45.882

The web slenderness is such that the Shear Buckling Check is not required.

Element satisfies the stability check !

## Kontrola nosilnosti sekundarnih prečk

Nonlinear calculation, Extreme : Cross-section

Selection : All

Class : MSN

Layer : sek preč

### EN 1993-1-1 Code Check

Member B364	IPE300	S 235	NC1	0.68
-------------	--------	-------	-----	------

Basic data EC3 : EN 1993	
partial safety factor Gamma M0 for resistance of cross-sections	1.00
partial safety factor Gamma M1 for resistance to instability	1.00

Basic data EC3 : EN 1993	
partial safety factor $\gamma_{M2}$ for resistance of net sections	1.25

Material data		
yield strength $f_y$	235.0	MPa
tension strength $f_u$	360.0	MPa
fabrication	rolled	

Width-to-thickness ratio for internal compression parts (EN 1993-1-1 : Tab.5.2. sheet 1).  
 ratio 35.01 on position 0.000 m

ratio		
maximum ratio 1	33.00	
maximum ratio 2	38.00	
maximum ratio 3	42.00	

==> Class cross-section 2  
 Width-to-thickness ratio for outstand flanges (EN 1993-1-1 : Tab.5.2. sheet 2).  
 ratio 5.28 on position 0.000 m

ratio		
maximum ratio 1	9.00	
maximum ratio 2	10.00	
maximum ratio 3	14.00	

==> Class cross-section 1  
**The critical check is on position 2.500 m**

Internal forces		
$N_{Ed}$	-3.03	kN
$V_{y,Ed}$	0.00	kN
$V_{z,Ed}$	0.00	kN
$T_{Ed}$	0.00	kNm
$M_{y,Ed}$	100.08	kNm
$M_{z,Ed}$	0.00	kNm

**Compression check**  
 According to article EN 1993-1-1 : 6.2.4 and formula (6.9)  
 Section classification is 1.

Table of values		
$N_{c,Rd}$	1264.30	kN
Unity check	0.00	-

**Bending moment check ( $M_y$ )**  
 According to article EN 1993-1-1 : 6.2.5. and formula (6.12)  
 Section classification is 1.

Table of values		
$M_{c,Rd}$	147.67	kNm
Unity check	0.68	-

**Combined bending, axial force and shear force check**  
 According to article EN 1993-1-1 : 6.2.9.1. and formula (6.31)  
 Section classification is 1.

Table of values		
$MN_{Vy,Rd}$	147.67	kNm
$MN_{Vz,Rd}$	29.42	kNm
$\alpha$	2.00	beta
Unity check	0.68	-

1.00



Element satisfies the section check !

....:STABILITY CHECK:....

**Flexural Buckling Check**

According to article EN 1993-1-1 : 6.3.1.1. and formula (6.46)

Buckling parameters	yy	zz	
Sway type	sway	non-sway	
System Length L	5.000	5.000	m
Buckling factor k	1.00	0.03	
Buckling length Lcr	5.000	0.150	m
Critical Euler load Ncr	6927.51	556198.27	kN
Slenderness	40.12	4.48	
Relative slenderness Lambda	0.43	0.05	
Limit slenderness Lambda,0	0.20	0.20	

The slenderness or compression force is such that Flexural Buckling effects may be ignored according to EN 1993-1-1 article 6.3.1.2(4)

**Lateral Torsional Buckling Check**

According to article EN 1993-1-1 : 6.3.2.1. and formula (6.54)

LTB Parameters		
Method for LTB curve	Art. 6.3.2.2.	
Wy	6.2840e-04	m <sup>3</sup>
Elastic critical moment Mcr	90815.11	kNm
Relative slenderness Lambda,LT	0.04	
Limit slenderness Lambda,LT,0	0.40	

The slenderness or bending moment is such that Lateral Torsional Buckling effects may be ignored according to EN 1993-1-1 article 6.3.2.2(4)

**Compression and bending check**

According to article EN 1993-1-1 : 6.3.3. and formula (6.61), (6.62)

Interaction Method 1

Table of values		
kyy	1.000	
kyz	0.691	
kzy	0.520	
kzz	0.999	
Delta My	0.00	kNm
Delta Mz	0.00	kNm
A	5.3800e-03	m <sup>2</sup>
Wy	6.2840e-04	m <sup>3</sup>
Wz	1.2520e-04	m <sup>3</sup>
NRk	1264.30	kN
My,Rk	147.67	kNm
Mz,Rk	29.42	kNm
My,Ed	100.08	kNm
Mz,Ed	0.00	kNm
Interaction Method 1		
Mcr0	80367.35	kNm
reduced slenderness 0	0.04	
Cmy,0	1.000	
Cmz,0	1.000	
Cmy	1.000	
Cmz	1.000	
CmLT	1.000	
muy	1.000	
muz	1.000	
wy	1.128	
wz	1.500	
np1	0.002	
aLT	0.998	
bLT	0.000	
cLT	0.002	
dLT	0.000	
eLT	0.493	
Cyy	1.000	
Cyz	1.001	
Czy	1.000	
Czz	1.001	

Unity check (6.61) = 0.00 + 0.68 + 0.00 = 0.68

Unity check (6.62) = 0.00 + 0.35 + 0.00 = 0.36

Element satisfies the stability check !

### EN 1993-1-1 Code Check

Member B405	IPE270	S 235	NC1	0.81
-------------	--------	-------	-----	------

Basic data EC3 : EN 1993			
partial safety factor	Gamma M0 for resistance of cross-sections		1.00
partial safety factor	Gamma M1 for resistance to instability		1.00
partial safety factor	Gamma M2 for resistance of net sections		1.25

Material data		
yield strength fy	235.0	MP a
tension strength fu	360.0	MP a
fabrication	rolled	

### .....SECTION CHECK:....

Width-to-thickness ratio for internal compression parts (EN 1993-1-1 : Tab.5.2. sheet 1).

ratio 33.27 on position 0.000 m

ratio		
maximum ratio	1	33.00
maximum ratio	2	38.00
maximum ratio	3	42.00

==> Class cross-section 2

Width-to-thickness ratio for outstand flanges (EN 1993-1-1 : Tab.5.2. sheet 2).

ratio 4.82 on position 0.000 m

ratio		
maximum ratio	1	9.00
maximum ratio	2	10.00
maximum ratio	3	14.00

==> Class cross-section 1

**The critical check is on position 2.500 m**

Internal forces		
NEd	-4.56	kN
Vy,Ed	0.00	kN
Vz,Ed	0.00	kN
TEd	0.00	kNm
My,Ed	91.80	kNm
Mz,Ed	0.00	kNm

### Compression check

According to article EN 1993-1-1 : 6.2.4 and formula (6.9)

Section classification is 1.

Table of values		
Nc,Rd	1078.65	kN
Unity check	0.00	-

### Shear check (Vz)

According to article EN 1993-1-1 : 6.2.6. and formula (6.17)

Table of values		
Vc,Rd	299.75	kN
Unity check	0.00	-

### Bending moment check (My)

According to article EN 1993-1-1 : 6.2.5. and formula (6.12)

Section classification is 1.

Table of values		
*Student version* *Student version* *Student version*		
Mc,Rd	113.74	kNm
Unity check	0.81	-

### Combined bending, axial force and shear force check

According to article EN 1993-1-1 : 6.2.9.1. and formula (6.31)

Section classification is 1.

Table of values		
*Student version* *Student version* *Student version*		
MNVy,Rd	113.74	kNm
MNVz,Rd	22.78	kNm

alfa 2.00 beta 1.00  
Unity check 0.81 -

Element satisfies the section check !

....:STABILITY CHECK:....

### Flexural Buckling Check

According to article EN 1993-1-1 : 6.3.1.1. and formula (6.46)

Buckling parameters	yy	zz	
*Student version* *Student version* *Student version* *Student version* *Student			
Sway type	sway	non-sway	
System Length L	5.000	5.000	m
Buckling factor k	1.00	0.03	
Buckling length Lcr	5.000	0.150	m
Critical Euler load Ncr	4800.18	386796.38	kN
Slenderness	44.52	4.96	
Relative slenderness Lambda	0.47	0.05	
Limit slenderness Lambda,0	0.20	0.20	

The slenderness or compression force is such that Flexural Buckling effects may be ignored according to EN 1993-1-1 article 6.3.1.2(4)

### Lateral Torsional Buckling Check

According to article EN 1993-1-1 : 6.3.2.1. and formula (6.54)

LTB Parameters		
*Student version* *Student version* *Student version* *Student version* *S		
Method for LTB curve	Art. 6.3.2.2.	
Wy	4.8400e-04	m <sup>3</sup>
Elastic critical moment Mcr	56720.23	kNm
Relative slenderness Lambda,LT	0.04	
Limit slenderness Lambda,LT,0	0.40	

The slenderness or bending moment is such that Lateral Torsional Buckling effects may be ignored according to EN 1993-1-1 article 6.3.2.2(4)

### Compression and bending check

According to article EN 1993-1-1 : 6.3.3. and formula (6.61), (6.62)

Interaction Method 1

Table of values		
*Student version* *Student version* *Student version* *Student		
kyy	1.000	
kyz	0.691	
kzy	0.521	
kzz	0.999	
Delta My	0.00	kNm
Delta Mz	0.00	kNm
A	4.5900e-03	m <sup>2</sup>
Wy	4.8400e-04	m <sup>3</sup>
Wz	9.6950e-05	m <sup>3</sup>
NRk	1078.65	kN
My,Rk	113.74	kNm
Mz,Rk	22.78	kNm
My,Ed	91.80	kNm
Mz,Ed	0.00	kNm
Interaction Method 1		
Mcr0	50194.89	kNm
reduced slenderness 0	0.05	
Cmy,0	1.000	
Cmz,0	1.000	
*Student version* *Student version* *Student version* *Stud		

Table of values	
Cmy	1.000
Cmz	1.000
CmLT	1.000
muy	1.000
muz	1.000
wy	1.128
wz	1.500
npl	0.004
aLT	0.997
bLT	0.000
cLT	0.004
dLT	0.000
eLT	0.651
Cyy	1.001
Cyz	1.002
Czy	1.000
Czz	1.001

Unity check (6.61) = 0.00 + 0.81 + 0.00 = 0.81  
 Unity check (6.62) = 0.00 + 0.42 + 0.00 = 0.42

### Shear buckling check

in buckling field 1

According to article EN 1993-1-5 : 5. & 7.1. and formula (5.10) & (7.1)

Table of values	
hw/t	37.818

The web slenderness is such that the Shear Buckling Check is not required.  
 Element satisfies the stability check !

### EN 1993-1-1 Code Check

Member B501	IPE270	S 235	NC1	0.88
-------------	--------	-------	-----	------

Basic data EC3 : EN 1993			
partial safety factor	Gamma M0 for resistance of cross-sections		1.00
partial safety factor	Gamma M1 for resistance to instability		1.00
partial safety factor	Gamma M2 for resistance of net sections		1.25

Material data		
yield strength fy	235.0	MP a
tension strength fu	360.0	MP a
fabrication	rolled	

### .....SECTION CHECK:....

Width-to-thickness ratio for internal compression parts (EN 1993-1-1 : Tab.5.2. sheet 1).  
 ratio 33.27 on position 0.455 m

ratio		
maximum ratio	1	71.85
maximum ratio	2	82.74
maximum ratio	3	124.00

==> Class cross-section 1

Width-to-thickness ratio for outstand flanges (EN 1993-1-1 : Tab.5.2. sheet 2).  
 ratio 4.82 on position 0.455 m

ratio		
maximum ratio	1	9.00
maximum ratio	2	10.00
maximum ratio	3	13.77

==> Class cross-section 1

**The critical check is on position 2.500 m**

Internal forces		
*Student version* *Student version* *Student version*		
N <sub>y,Ed</sub>	00000	kN
V <sub>z,Ed</sub>	0.00	kN
T <sub>Ed</sub>	0.00	kNm
M <sub>y,Ed</sub>	99.79	kNm
M <sub>z,Ed</sub>	0.00	kNm

### Compression check

According to article EN 1993-1-1 : 6.2.4 and formula (6.9)  
Section classification is 1.

Table of values		
*Student version* *Student version* *Student version*		
N <sub>c,Rd</sub>	1078.65	kN
Unity check	0.00	-

### Shear check (V<sub>y</sub>)

According to article EN 1993-1-1 : 6.2.6. and formula (6.17)

Table of values		
*Student version* *Student version* *Student version*		
V <sub>c,Rd</sub>	399.25	kN
Unity check	0.00	-

### Shear check (V<sub>z</sub>)

According to article EN 1993-1-1 : 6.2.6. and formula (6.17)

Table of values		
*Student version* *Student version* *Student version*		
V <sub>c,Rd</sub>	299.75	kN
Unity check	0.00	-

### Bending moment check (M<sub>y</sub>)

According to article EN 1993-1-1 : 6.2.5. and formula (6.12)  
Section classification is 1.

Table of values		
*Student version* *Student version* *Student version*		
M <sub>c,Rd</sub>	113.74	kNm
Unity check	0.88	-

### Combined bending, axial force and shear force check

According to article EN 1993-1-1 : 6.2.9.1. and formula (6.31)  
Section classification is 1.

Table of values		
*Student version* *Student version* *Student version*		
MNV <sub>y,Rd</sub>	113.74	kNm
MNV <sub>z,Rd</sub>	22.78	kNm

alpha 2.00 beta 1.00  
Unity check 0.88 -

Element satisfies the section check !

### ....:STABILITY CHECK:....

#### Flexural Buckling Check

According to article EN 1993-1-1 : 6.3.1.1. and formula (6.46)

Buckling parameters		yy	zz	
*Student version* *Student version* *Student version* *Student version* *Student version*				
Sway type		sway	non-sway	
System Length L		5.000	5.000	m
Buckling factor k		1.00	0.03	
Buckling length L <sub>cr</sub>		5.000	0.150	m
Critical Euler load N <sub>cr</sub>		4800.18	386796.38	kN
Slenderness		44.52	4.96	
Relative slenderness Lambda		0.47	0.05	
*Student version* *Student version* *Student version* *Student version* *Student version*				

Buckling parameters			
	yy	zz	
Limit slenderness Lambda,0	0.20	0.20	

The slenderness or compression force is such that Flexural Buckling effects may be ignored according to EN 1993-1-1 article 6.3.1.2(4)

### Lateral Torsional Buckling Check

According to article EN 1993-1-1 : 6.3.2.1. and formula (6.54)

LTB Parameters		
Method for LTB curve	Art. 6.3.2.2.	
Wy	4.8400e-04	m <sup>3</sup>
Elastic critical moment Mcr	56720.23	kNm
Relative slenderness Lambda,LT	0.04	
Limit slenderness Lambda,LT,0	0.40	

The slenderness or bending moment is such that Lateral Torsional Buckling effects may be ignored according to EN 1993-1-1 article 6.3.2.2(4)

### Compression and bending check

According to article EN 1993-1-1 : 6.3.3. and formula (6.61), (6.62)  
Interaction Method 1

Table of values		
kyy	1.000	
kyz	0.693	
kzy	0.520	
kzz	1.000	
Delta My	0.00	kNm
Delta Mz	0.00	kNm
A	4.5900e-03	m <sup>2</sup>
Wy	4.8400e-04	m <sup>3</sup>
Wz	9.6950e-05	m <sup>3</sup>
NRk	1078.65	kN
My,Rk	113.74	kNm
Mz,Rk	22.78	kNm
My,Ed	99.79	kNm
Mz,Ed	0.00	kNm
Interaction Method 1		
Mcr0	50194.89	kNm
reduced slenderness 0	0.05	
Cmy,0	1.000	
Cmz,0	1.000	
Cmy	1.000	
Cmz	1.000	
CmLT	1.000	
muy	1.000	
muz	1.000	
wy	1.128	
wz	1.500	
npI	0.000	
aLT	0.997	
bLT	0.000	
cLT	0.004	
dLT	0.000	
eLT	0.708	
Cyy	1.000	
Cyz	0.998	
Czy	1.000	
Czz	1.000	

Unity check (6.61) = 0.00 + 0.88 + 0.00 = 0.88

Unity check (6.62) = 0.00 + 0.46 + 0.00 = 0.46

### Shear buckling check

in buckling field 1

According to article EN 1993-1-5 : 5. & 7.1. and formula (5.10) & (7.1)

Table of values	
hw/t	37.818

The web slenderness is such that the Shear Buckling Check is not required.

Element satisfies the stability check !

## Kontrola nosilnosti centričnega povezja

Nonlinear calculation, Extreme : Cross-section  
 Selection : All  
 Class : Potres  
 Layer : povezje

### EN 1993-1-1 Code Check

Member B610	VHP60/60x6.0	S 235	NC11	0.93
-------------	--------------	-------	------	------

Basic data EC3 : EN 1993				
partial safety factor	Gamma M0	for resistance of	cross-sections	1.00
partial safety factor	Gamma M1	for resistance to	instability	1.00
partial safety factor	Gamma M2	for resistance of	net sections	1.25

Material data		
yield strength fy	235.0	MP a
tension strength fu	360.0	MP a
fabrication	rolled	

....:SECTION CHECK:....

The critical check is on position 5.936 m

Internal forces		
NEd	261.22	kN
Vy,Ed	0.00	kN
Vz,Ed	0.00	kN
TEd	0.00	kNm
My,Ed	0.00	kNm
Mz,Ed	0.00	kNm

### Normal force check

According to article EN 1993-1-1 : 6.2.3. and formula (6.5)

Table of values		
Nt.Rd	282.00	kN
Unity check	0.93	-

### Combined bending, axial force and shear force check

According to article EN 1993-1-1 : 6.2.9.1. and formula (6.31)

Section classification is 1.

Table of values		
MNVy.Rd	0.51	kNm
MNVz.Rd	0.51	kNm

alfa 6.00 beta 6.00  
 Unity check 0.00 -

Element satisfies the section check !

....:STABILITY CHECK:....

Element satisfies the stability check !

### EN 1993-1-1 Code Check

Member B612	VHP60/60x6.0	S 235	NC11	0.99
-------------	--------------	-------	------	------

Basic data EC3 : EN 1993				
partial safety factor	Gamma M0	for resistance of	cross-sections	1.00
partial safety factor	Gamma M1	for resistance to	instability	1.00
partial safety factor	Gamma M2	for resistance of	net sections	1.25

Material data		
yield strength fy	235.0	MP a
tension strength fu	360.0	MP a

Material data		
*Student version* *Student version* *Student version*		
fabrication	rolled	

.....SECTION CHECK:....

The critical check is on position 5.831 m

Internal forces		
*Student version* *Student version* *Student version*		
NEd	280.56	kN
Vy,Ed	0.00	kN
Vz,Ed	0.00	kN
TEd	0.00	kNm
My,Ed	0.00	kNm
Mz,Ed	0.00	kNm

### Normal force check

According to article EN 1993-1-1 : 6.2.3. and formula (6.5)

Table of values		
*Student version* *Student version* *Student version*		
Nt.Rd	282.00	kN
Unity check	0.99	-

### Combined bending, axial force and shear force check

According to article EN 1993-1-1 : 6.2.9.1. and formula (6.31)

Section classification is 1.

Table of values		
*Student version* *Student version* *Student version*		
MNVy.Rd	0.04	kNm
MNVz.Rd	0.04	kNm

alfa 1.66 beta 1.66  
Unity check 0.00 -

Element satisfies the section check !

.....STABILITY CHECK:....

Element satisfies the stability check !

### EN 1993-1-1 Code Check

Member B614	VHP50/50x5.0	S 235	NC11	0.97
-------------	--------------	-------	------	------

Basic data EC3 : EN 1993			
*Student version* *Student version* *Student version* *Student version* *Student version* *Student version*			
partial safety factor	Gamma M0 for resistance of cross-sections		1.00
partial safety factor	Gamma M1 for resistance to instability		1.00
partial safety factor	Gamma M2 for resistance of net sections		1.25

Material data		
*Student version* *Student version* *Student version*		
yield strength fy	235.0	MP a
tension strength fu	360.0	MP a
fabrication	rolled	

.....SECTION CHECK:....

The critical check is on position 5.831 m

Internal forces		
*Student version* *Student version* *Student version*		
NEd	189.61	kN
Vy,Ed	0.00	kN
Vz,Ed	0.00	kN
TEd	0.00	kNm
My,Ed	0.00	kNm
Mz,Ed	0.00	kNm

### Normal force check

According to article EN 1993-1-1 : 6.2.3. and formula (6.5)



Table of values		
*Student version* *Student version* *Student version*		
Nt.Rd	196,46	kN
Unity check	0,97	-

#### Combined bending, axial force and shear force check

According to article EN 1993-1-1 : 6.2.9.1. and formula (6.31)

Section classification is 1.

Table of values		
*Student version* *Student version* *Student version*		
MNVy.Rd	0,14	kNm
MNVz.Rd	0,14	kNm

alfa 1.66 beta 1.66  
Unity check 0.00 -

Element satisfies the section check !

....:STABILITY CHECK:....

Element satisfies the stability check !

#### Teža jeklene konstrukcije

Name	Mass [kg]	Surface [m <sup>2</sup> ]	Volume [m <sup>3</sup> ]
*Student version* *Student version* *Student version*			
Total results :	959638,68	4942,307	3,4170e+02

CSS	Material	Unit mass [kg/m]	Length [m]	Mass [kg]	Surface [m <sup>2</sup> ]	Unit volume mass [kg/m <sup>3</sup> ]	Volume [m <sup>3</sup> ]
*Student version* *Student version* *Student version* *Student version* *Student version* *Student version* *Student version* *Student version*							
CS1 - HEB500	S 235	187,30	115,200	21577,08	244,734	7850,00	2,7487e+00
CS2 - IPE330	S 235	49,14	225,000	11056,73	282,140	7850,00	1,4085e+00
CS3 - IPE270	S 235	36,03	860,000	30987,14	895,199	7850,00	3,9474e+00
CS5 - streha - IPE500	S 235	91,06	225,000	20488,50	392,160	7850,00	2,6100e+00
CS6 - streha (sek) - IPE300	S 235	42,23	235,000	9924,76	272,508	7850,00	1,2643e+00
CS7 - streha (sov) - IPE270	S 235	36,03	195,000	7026,15	202,981	7850,00	8,9505e-01
CS8 - temelji - Rectangle (1000; 700)	C30/37	1750,00	460,000	805000,00	1564,000	2500,00	3,2200e+02
CS9 - Zunanji stebri - HEA280	S 235	76,38	165,600	12648,62	265,391	7850,00	1,6113e+00
CS10 - HEA340	S 235	105,19	216,000	22721,05	387,597	7850,00	2,8944e+00
CS13 - 2E - IPE360	S 235	57,07	225,000	12840,64	304,329	7850,00	1,6358e+00
CS4 - E1 - VHP60/60x6.0	S 235	9,42	213,708	2013,13	46,867	7850,00	2,5645e-01
CS11 - E2 - VHP60/60x6.0	S 235	9,42	209,914	1977,39	46,039	7850,00	2,5190e-01
CS12 - E3 - VHP50/50x5.0	S 235	6,56	209,914	1377,58	38,362	7850,00	1,7549e-01

Sekereš, D. 2011. Statični izračun jeklenega trietažnega poslovnega objekta.

Dipl. nal. – VSŠ. Ljubljana, UL, FGG, Odd. za gradbeništvo, Konstrukcijska smer.

---

## **PRILOGA B: Izpis rezultatov in kontrol za fasadno podkonstrukcijo iz programa SCIA Engineer**

## Model fasadne lege

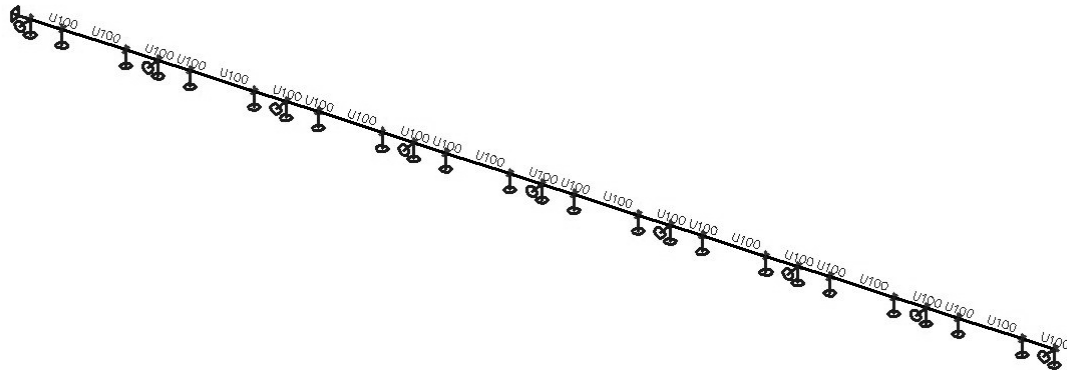

## Material

Name	Unit mass [kg/m <sup>3</sup> ]	E mod [MPa]	Poisson - nu	G mod [MPa]	Thermal exp [1/mK]	Lower limit [mm]	Upper limit [mm]	Fy [MPa]	Fu [MPa]
*Student version* *Student version* *Student version* *Student version* *Student version* *Student version* *Student version* *Student version* *Student version*									
S 235	7850,00	2,1000e+05	0,3	8,0769e+04	0,01e-003	0 40	40 80	235,0	360,0

## Lastna obtežba

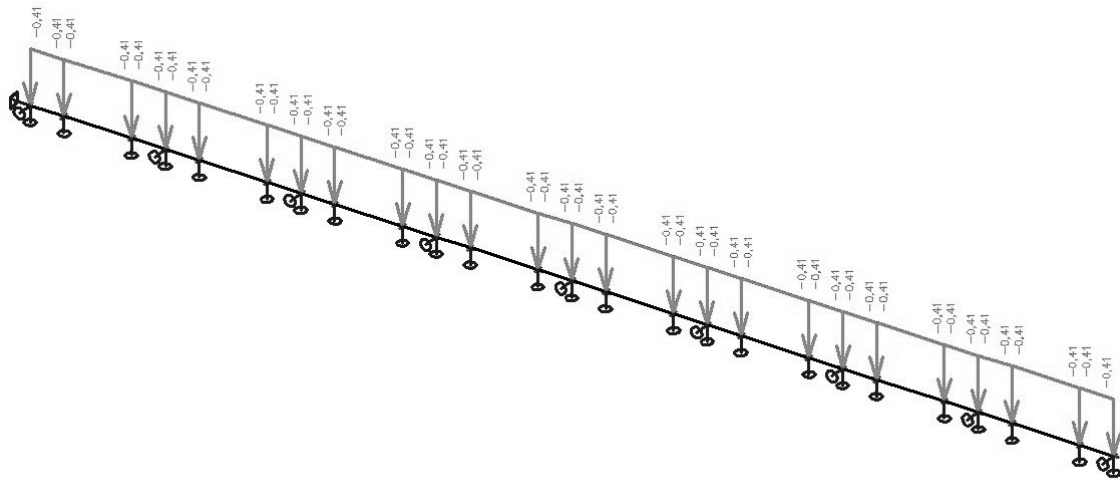

## Obtežba vetra

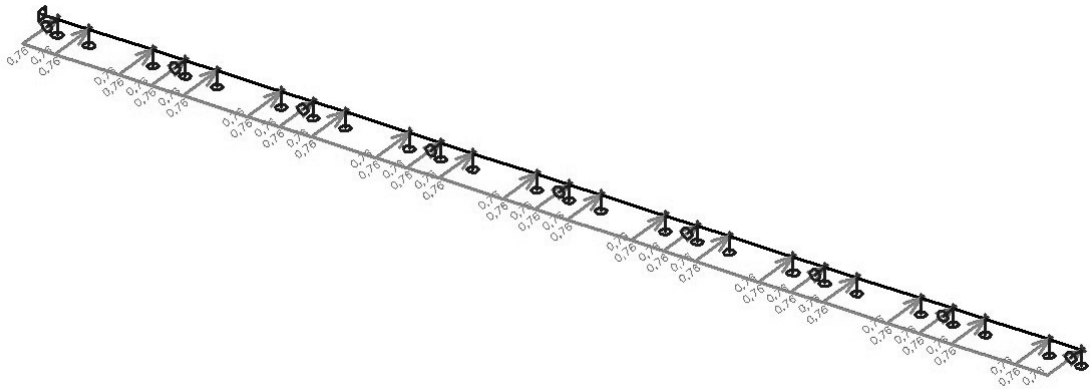

## Kombinacije

Name	Type	Load cases	Coeff. [-]
*Student version* *Student version* *Student version* *Student version*			
MSN	Envelope - ultimate	LC1 - lastna	1,35
		LC2 - stalna	1,35
		LC3 - veter	1,50
MSU	Envelope - ultimate	LC1 - lastna	1,00
		LC2 - stalna	1,00
		LC3 - veter	1,00

## Reakcije

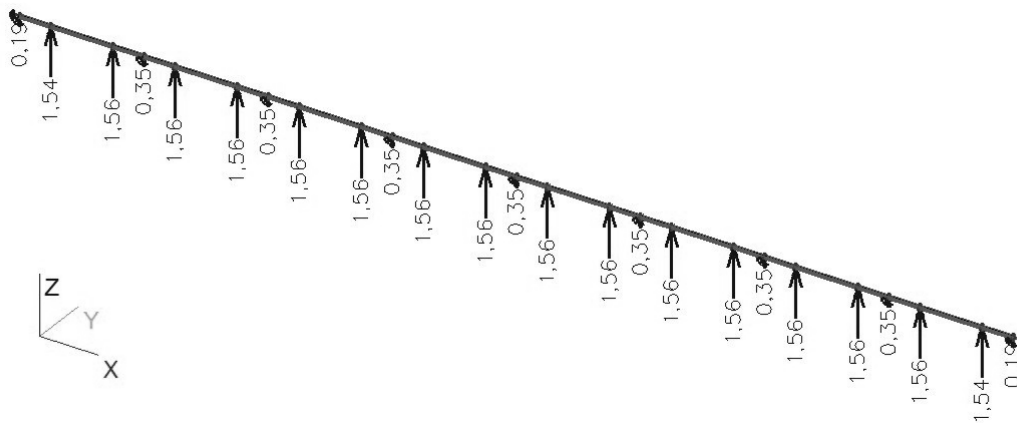

Upogibni moment  $M_y$  za MSN

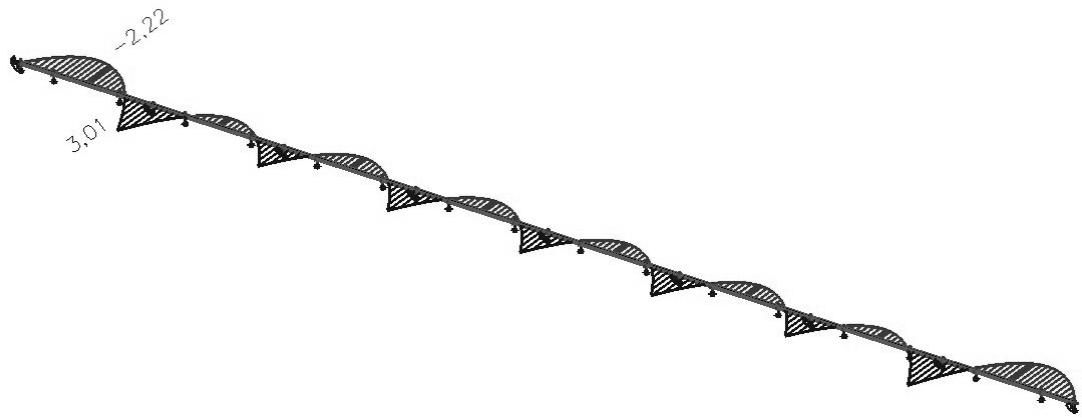

Upogibni moment  $M_z$  za MSN

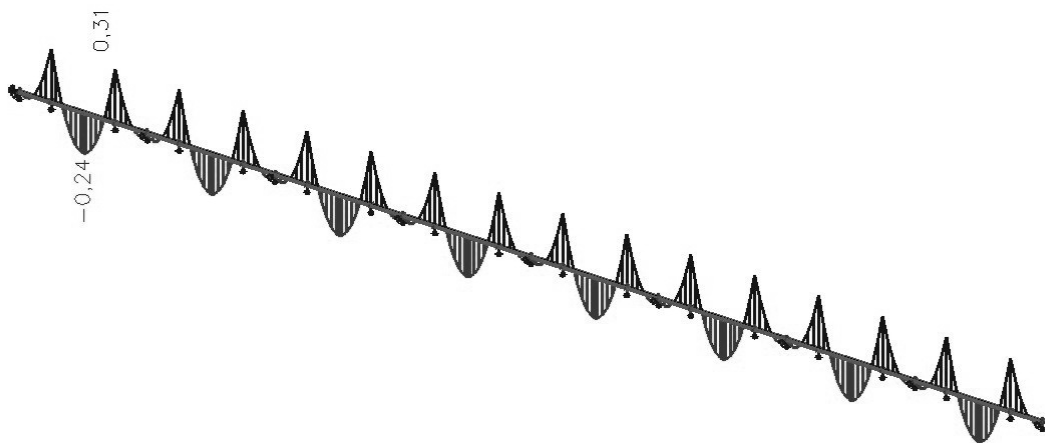

### Vertikalni pomik uz za MSU

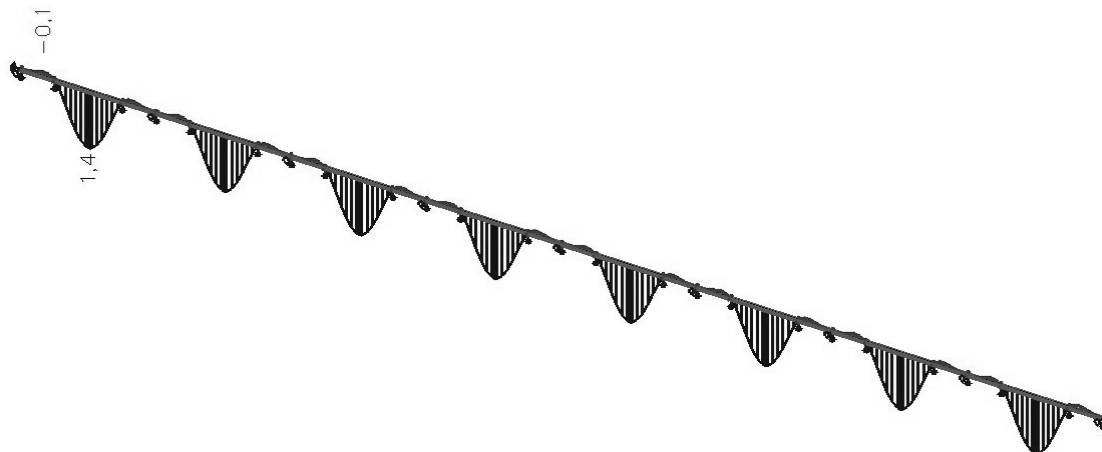

### Horizontalni pomik uy za MSU

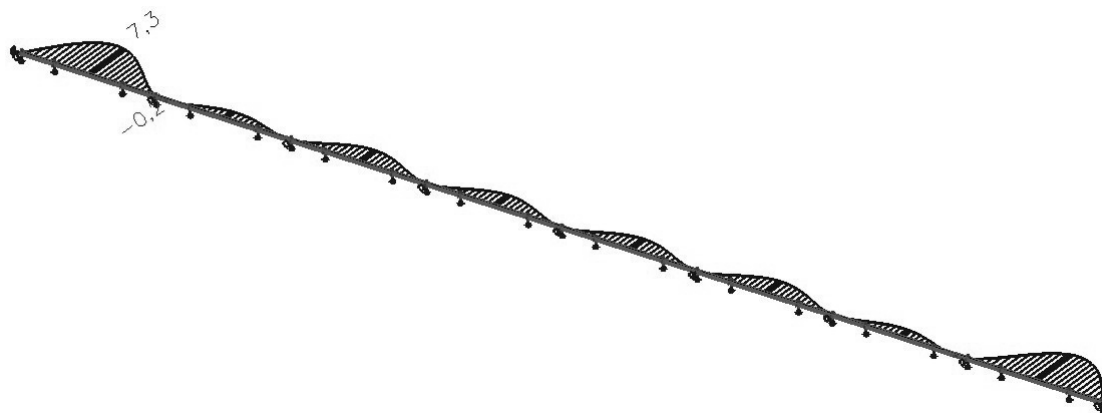

### Kontrole nosilnosti

Linear calculation, Extreme : Cross-section  
 Selection : All  
 Combinations : MSN

#### EN 1993-1-1 Code Check

Member B3	U100	S 235	MSN/2	0.47
-----------	------	-------	-------	------

Basic data EC3 : EN 1993				
*Student version* *Student version* *Student version* *Student version* *Student version*				
partial safety factor	Gamma	M0 for resistance of cross-sections		1.00
partial safety factor	Gamma	M1 for resistance to instability		1.00
partial safety factor	Gamma	M2 for resistance of net sections		1.25

Material data		
*Student version* *Student version*		
yield strength fy	235.0	MP a
tension strength fu	360.0	MP a
fab	rolled	

Width-to-thickness ratio for internal compression parts (EN 1993-1-1 : Tab.5.2. sheet 1).  
ratio 11.00 on position 0.625 m

ratio		
*Student version* *Student version*		
maximum ratio	1	72.00
maximum ratio	2	83.00
maximum ratio	3	124.59

==> Class cross-section 1  
Width-to-thickness ratio for outstand flanges (EN 1993-1-1 : Tab.5.2. sheet 2).  
ratio 4.18 on position 0.000 m

ratio		
*Student version* *Student version* *Student version*		
maximum ratio	1	46.89
maximum ratio	2	52.10
maximum ratio	3	41.22

==> Class cross-section 1  
**The critical check is on position 1.250 m**

Internal forces		
*Student version* *Student version* *Student version*		
NEd	0.00	kN
Vy,Ed	0.17	kN
Vz,Ed	3.45	kN
TEd	0.00	kNm
My,Ed	3.01	kNm
Mz,Ed	-0.02	kNm

**Shear check (Vy)**  
According to article EN 1993-1-1 : 6.2.6. and formula (6.17)

Table of values		
*Student version* *Student version* *Student version*		
Vc,Rd	98.60	kN
Unity check	0.00	-

**Shear check (Vz)**  
According to article EN 1993-1-1 : 6.2.6. and formula (6.17)

Table of values		
*Student version* *Student version* *Student version*		
Vc,Rd	84.56	kN
Unity check	0.04	-

**Bending moment check (My)**  
According to article EN 1993-1-1 : 6.2.5. and formula (6.12)  
Section classification is 1.

Table of values		
*Student version* *Student version* *Student version*		
Mc,Rd	11.52	kNm
Unity check	0.26	-

**Bending moment check (Mz)**  
According to article EN 1993-1-1 : 6.2.5. and formula (6.12)  
Section classification is 1.

Table of values		
*Student version* *Student version* *Student version*		
Mc,Rd	4.07	kNm
Unity check	0.00	-

### Combined bending, axial force and shear force check

According to article EN 1993-1-1: 6.2.9.2. & 6.2.10 and formula (6.42)  
Section classification is 3.

Table of values		
sigma N	0.0	MP a
sigma Myy	-73.0	MP a
sigma Mzz	-2.0	MP a

ro 0.00 place 3  
Unity check 0.32 -

Element satisfies the section check !

....:STABILITY CHECK:....

### Lateral Torsional Buckling Check

According to article EN 1993-1-1 : 6.3.2.1. and formula (6.54)

LTB Parameters			
Method for LTB curve	Art. 6.3.2.2.		
Wy	4.1200e-05	m <sup>3</sup>	
Elastic critical moment Mcr	33.10	kNm	
Relative slenderness Lambda,LT	0.54		
Limit slenderness Lambda,LT,0	0.40		

The slenderness or bending moment is such that Lateral Torsional Buckling effects may be ignored according to EN 1993-1-1 article 6.3.2.2(4)

### Compression and bending check

According to article EN 1993-1-1 : 6.3.3. and formula (6.61), (6.62)  
Interaction Method 1

Table of values		
kyy	1.000	
kyz	1.000	
kzy	1.000	
kzz	1.000	
Delta My	0.00	kNm
Delta Mz	0.00	kNm
A	1.3500e-03	m <sup>2</sup>
Wy	4.1200e-05	m <sup>3</sup>
Wz	8.4900e-06	m <sup>3</sup>
NRk	317.25	kN
My,Rk	9.68	kNm
Mz,Rk	2.00	kNm
My,Ed	3.01	kNm
Mz,Ed	0.31	kNm
Interaction Method 1		
Mcr0	33.10	kNm
reduced slenderness 0	0.54	
Cmy,0	1.000	
Cmz,0	1.000	
Cmy	1.000	
Cmz	1.000	
CmLT	1.000	
muy	1.000	
muz	1.000	
wy	1.189	
wz	1.500	
np1	-0.000	
aLT	0.986	
bLT	0.003	
cLT	0.133	
dLT	0.028	
eLT	0.309	
Cyy	0.999	
Cyz	0.933	
Czy	0.995	
Czz	1.000	

Unity check (6.61) = 0.00 + 0.31 + 0.15 = 0.47

Unity check (6.62) = 0.00 + 0.31 + 0.15 = 0.47

### Shear buckling check

in buckling field 1

According to article EN 1993-1-5 : 5. & 7.1. and formula (5.10) & (7.1)



Table of values	
hw/t	13,833

The web slenderness is such that the Shear Buckling Check is not required.  
Element satisfies the stability check !

### Lastna teža

Name	Mass [kg]	Surface [m <sup>2</sup> ]	Volume [m <sup>3</sup> ]
*Student version* *Student version* *Student version* *Student version*			
Total results :	423,90	14,876	5,4000e-02

CSS	Material	Unit mass [kg/m]	Length [m]	Mass [kg]	Surface [m <sup>2</sup> ]	Unit volume mass [kg/m <sup>3</sup> ]	Volume [m <sup>3</sup> ]
*Student version* *Student version* *Student version* *Student version* *Student version* *Student version* *Student version* *Student version* *Student version* *Student version*							
CS1 - U100	S 235	10,60	40,000	423,90	14,876	7850,00	5,4000e-02

Sekereš, D. 2011. Statični izračun jeklenega trietažnega poslovnega objekta.

Dipl. nal. – VSŠ. Ljubljana, UL, FGG, Odd. za gradbeništvo, Konstrukcijska smer.

---

## **PRILOGA C: Izpis rezultatov in kontrol za spoje iz programa SCIA Engineer**

**Momentni spoj prečke na steber (Spoj 1)**

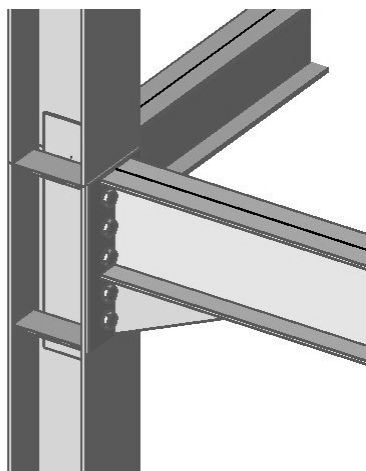

**Momentni spoj prečke na steber (Spoj 2)**

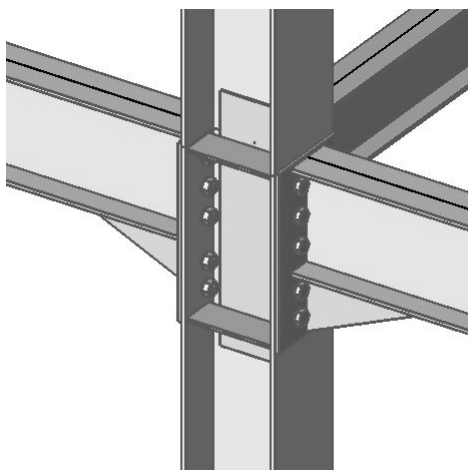

**Momentni spoj prečke na steber (Spoj 3)**

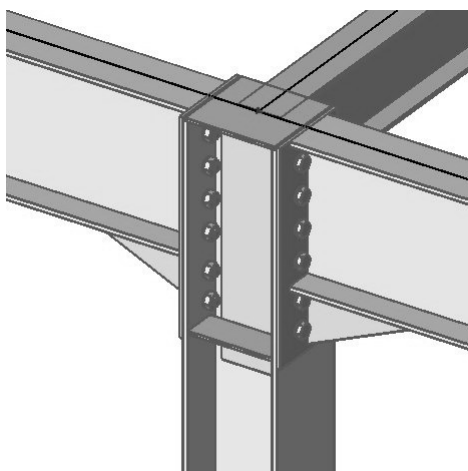

### Momentni spoj prečke na steber (Spoj 4)

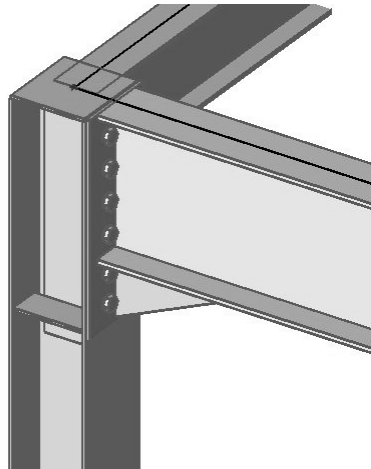

### Členkasti spoj primarnega nosilca na sekundarni nosilec (Spoj 5)

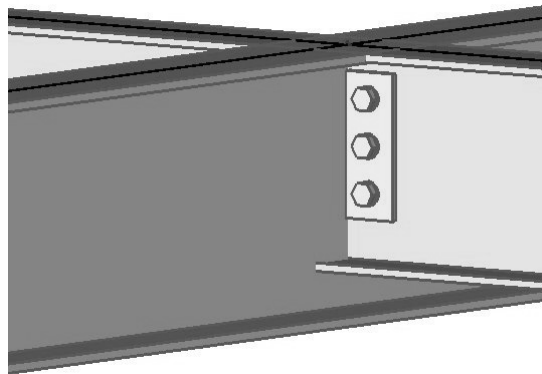

## Steel Connection

Spoj 1

N 1

Frame bolted

Simple T

Name	CrossSection	Length [m]	Shape	Beg. node	End node	Type	FEM type	Layer
*Student version* *Student version* *Student version* *Student version* *Student version* *Student version* *Student version*								
B10	CS9 - Zunanji stebri - HEA280	3,200	Line	N13	N1	column (100)	standard	Z steber
B11	CS9 - Zunanji stebri - HEA280	3,000	Line	N1	N5	column (100)	standard	Z steber
B1	CS2 - IPE330	5,000	Line	N1	N2	beam (80)	standard	prečke

Type Name	Bolts
Internal bolts distance [mm]	100
External bolts distance [mm]	80
Selected bolt assembly	M27 - 10.9
Length [mm]	70
1.Location [mm]	490
2.Location [mm]	390
3.Location [mm]	290
4.Location [mm]	170
5.Location [mm]	80
Bolt pattern	2 bolts/row

\*Student version\* \*Student version\* \*Student version\* \*Student version\* \*Student version\* \*Student version\* \*Student version\* \*Student version\* \*Student version\* \*Student version\*

Bolt assembly

Bolt assembly	M27 - 10.9 M27 - DIN 6914 M27 - DIN 6916 M27 - DIN 6915 ✓ ✓ 10 10.9 Normal 200 1000,0										
Bolts	Type Name	Name	Bore hole [mm]	Diameter required for bolt key [mm]	Head diameter [mm]	Diagonal head diameter [mm]	Head height [mm]	Gross cross-section area [mm²]	Tensile stress area [mm²]	Diameter [mm]	
	*Student version* *Student version* *Student version* *Student version* *Student version* *Student version* *Student version*										
	Bolts	M27 - DIN 6914	30	120	46	51	17	573	459	27	
Nut	Type Name										Nut
	Name										M27 - DIN 6915
	Diameter [mm]										46
	Diagonal diameter [mm]										51
	Height [mm]										22
Washer	Type Name	Washer									
	Name										M27 - DIN 6916
	Internal diameter [mm]										28
	External diameter [mm]										50
	Thickness [mm]										5

Name	End
Material	S 355
Thickness[mm]	12
Top [mm]	10
Bottom [mm]	10
Left [mm]	60
Right [mm]	60
Width [mm]	280
Height [mm]	570

Name	Sti
Material	S 355
Decrease [mm]	1
Thickness[mm]	10
*Student version* *Student version* *Student version*	
Name	Sti9
Material	S 355
Decrease [mm]	1
Thickness[mm]	10

Type Name	Name	Type	Input type	Height [m]	Thickness [m]	Angle [deg]
*Student version* *Student version* *Student version* *Student version* *Student version* *Student version* *Student version*						

CadHaunch	CadHaunch	Plate	Height x angle	0,220	0,010	60,00
Type Name	CadHaunch	Web doubler				
Name	Web doubler					
Thickness[mm]	6					
Material	S 355					
Size of web doubler	Large					
Type of web doubler	Double					
Width [mm]	196					
Height [mm]	787					

According to EN 1993-1-8

<b>Haunch underPlate</b>		
*Student version* *Student version* *Student version* *Student version*		
hc	201.37	mm
lc	500.00	mm
tw	10.00	mm
weld awc	4.00	mm

Partial safety factors		
Gamma M0		1.00
Gamma M1		1.00
Gamma M2		1.25
Gamma M3		1.25

### 1. Internal forces

NC1		
N	9.88	kN
Vz	51.23	kN
My	-46.71	kNm

Tension top

### 2. Design moment resistance MRd

#### 2.1. Design resistance of basic components

For individual bolt row :

$$B_{t,Rd} = 330.48 \text{ kN}$$

row	(Ft,fc,Rd)	Ft,ep,Rd
1	249.54	321.20
2	249.54	321.20
3	249.54	321.20
4	249.54	321.20
5	249.54	321.20

$$N_{j,Rd} = 149.47 \text{ kN}$$

data		
Column Web in tension (Ft,wc,Rd)	149.47	kN
Beam Web in tension (Ft,wb,Rd)	4620.62	kN
Endplate in bending (Ft,ep,Rd)	2424.55	kN
Column Flange in tension (Ft,fc,Rd)	495.77	kN
Bolts in Tension (Bt,Rd)	3304.80	kN

data		
Column web in shear (Vwp,Rd)	579.53	kN
Column web in compression (Fc,wc,Rd)	149.47	kN
Fc,h,Rd	149.47	kN

#### 2.2. Determination of $M_{j,Rd}$

row	h[mm]	Ft[kN]
1	474.25	149.47
2	374.25	0.00
3	274.25	0.00
4	154.25	0.00
5	64.25	0.00

$$M_{j,Rd} = 70.89 \text{ kNm}$$

#### 2.3. Determination of $M_{j,Rd}$ for compressed haunch at beam

data		
$M_{j,Rd}$	76.83	kNm
MEd	-10.92	kNm

### 3. Design shear resistance VRd

$$V_{Rd} = 653.48 \text{ kN}$$

### 4. Stiffness calculation

#### 4.1. Design rotational stiffness

Sj data		
Sj	56.99	MNm/rad

Sj data		
*Student version* *Student version* *Student version*		
Sj,ini	56.99	MNm/rad
z	474.25	mm
mu	1.00	
k1	3.80	mm
k2	-	
keq	1.77	mm

#### 4.2. Stiffness classification

Not applicable.

#### 4.3 Check of stiffness requirement

Not applicable.

#### 4.4 Ductility classification

The failure mode is not situated in the column shear zone.

In the endplate we have the following :

$$t \leq 0.36 \sqrt{f_{ub}/f_y} d$$

This results in a ductile classification for ductility : class 1.

### 5. Unity checks

Unity checks	
*Student version* *Student version* *Student version*	
M <sub>Sd</sub> /M <sub>jRd</sub>	0.66
V <sub>Sd</sub> /V <sub>Rd</sub>	0.08
Unity check M/M <sub>Rd</sub> + N/N <sub>Rd</sub>	0.73

The connection satisfies.

### 6. Design calculations

data		
*Student version* *Student version* *Student version*		
af	6.00	mm
aw	4.00	mm
Minimum th	5.95	mm

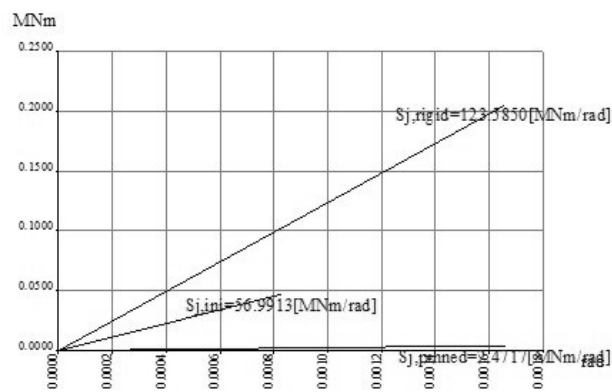
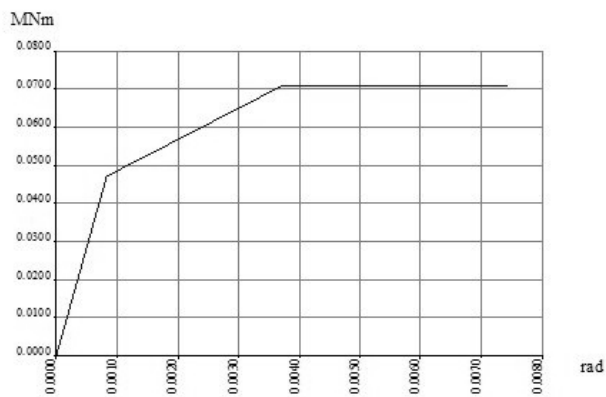

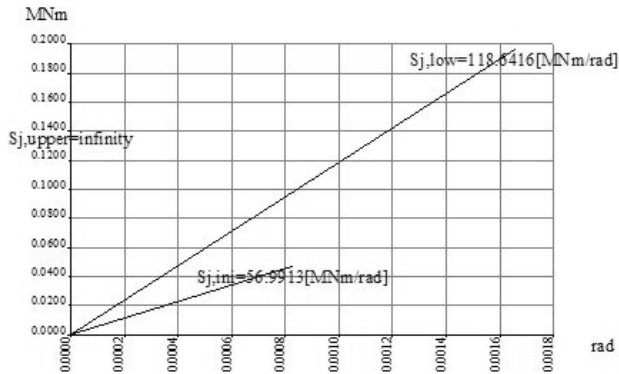

\*Student version\* \*Student version\* \*Student version\* \*Student version\* \*Student version\* \*Student version\* \*Student version\* \*Student version\* \*Student version\* \*Student version\*

Spoj 2

N6

Frame bolted

Cross

Name	CrossSection	Length [m]	Shape	Beg. node	End node	Type	FEM type	Layer
B14	CS10 - HEA340	3,000	Line	N2	N6	column (100)	standard	steber
B15	CS10 - HEA340	3,000	Line	N6	N10	column (100)	standard	steber
B5	CS13 - 2E - IPE360	5,000	Line	N6	N7	beam (80)	standard	prečke
B4	CS13 - 2E - IPE360	5,000	Line	N5	N6	beam (80)	standard	prečke

Type Name	Bolts
Internal bolts distance [mm]	100
External bolts distance [mm]	80
Selected bolt assembly	M27 - 10.9
Length [mm]	70
1.Location [mm]	520
2.Location [mm]	420
3.Location [mm]	320
4.Location [mm]	170
5.Location [mm]	80
Bolt pattern	2 bolts/row

Bolt assembly	Bolt assembly M27 - 10.9 M27 - DIN 6914 M27 - DIN 6916 M27 - DIN 6915 ✓ ✓ 10 10.9 Normal 200	1000,0
---------------	--	--------

Boils	Type Name	Name	Bore hole [mm]	Diameter required for bolt key [mm]	Head diameter [mm]	Diagonal head diameter [mm]	Head height [mm]	Gross cross-section area [mm <sup>2</sup> ]	Tensile stress area [mm <sup>2</sup> ]	Diameter [mm]
	Boils	M27 - DIN 6914	30	120	46	51	17	573	459	27

Nut	Type Name	Nut
	Name	M27 - DIN 6915
	Diameter [mm]	46
	Diagonal diameter [mm]	51
	Height [mm]	22

Washer	Type Name	Washer
	Name	M27 - DIN 6916
	Internal diameter [mm]	28
	External diameter [mm]	50
	Thickness [mm]	5

Name	End3
Material	S 355
Thickness[mm]	12
Top [mm]	10
Bottom [mm]	10

\*Student version\* \*Student version\* \*Student version\*



Left [mm]	65
Right [mm]	65
Width [mm]	300
Height [mm]	600

Name	Sti3
Material	S 355
Decrease [mm]	1
Thickness[mm]	10
*Student version* *Student version* *Student version*	
Name	Sti4
Material	S 355
Decrease [mm]	1
Thickness[mm]	10

Type Name	Name	Type	Input type	Height [m]	Thickness [m]	Angle [deg]
*Student version* *Student version* *Student version* *Student version* *Student version* *Student version* *Student version* *Student version*						
CadHaunch	CadHaunch1	Plate	Height x angle	0,220	0,010	60,00

Type Name	CadHaunch1	Plate	Web doubler
Name	Web doubler1		
Thickness[mm]	6		
Material	S 355		
Size of web doubler	Large		
Type of web doubler	Double		
Width [mm]	243		
Height [mm]	854		

According to EN 1993-1-8

<b>Haunch underPlate</b>		
*Student version* *Student version* *Student version* *Student version*		
hc	201.37	mm
lc	500.00	mm
tw	10.00	mm
weld awc	3.00	mm

<b>Partial safety factors</b>	
*Student version* *Student version* *Student version*	
Gamma M0	1.00
Gamma M1	1.00
Gamma M2	1.25
Gamma M3	1.25

**1. Internal forces**

NC1		
*Student version* *Student version*		
N	-2.41	kN
Vz	55.07	kN
My	-59.52	kNm

Tension top

**2. Design moment resistance MRd**

**2.1. Design resistance of basic components**

For individual bolt row :

$B_t, R_d = 330.48 \text{ kN}$

row	(Ft,fc,Rd)	Ft,ep,Rd
*Student version* *Student version* *Student version*		
1	401.99	321.20
2	201.00	321.20
3	201.00	321.20
4	201.00	321.20
5	401.99	321.20

$N_j, R_d = 149.47 \text{ kN}$

data		
*Student version* *Student version* *Student version* *Student version* *Student version*		
Column web in compression (Fc,wc,Rd)	149.47	kN
Beam flange in compression (Fc,fb,Rd)	298.94	kN

data		
*Student version* *Student version* *Student version* *Student version* *Student version*		
Column web in shear (Vwp,Rd)	837.21	kN
Column web in compression (Fc,wc,Rd)	149.47	kN
Fc,h,Rd	149.47	kN

## 2.2. Determination of $M_j, R_d$

row	h[mm]	Ft[kN]
*Student version* *Student version* *Student version*		
1	503.65	149.47
2	403.65	0.00
3	303.65	0.00
4	153.65	0.00
5	63.65	0.00

$M_j, R_d = 75.28 \text{ kNm}$

## 2.3. Determination of $M_j, R_d$ for compressed haunch at beam

data		
*Student version* *Student version* *Student version*		
$M_j, R_d$	82.97	kNm
MEd	-18.93	kNm

## 3. Design shear resistance $V_{Rd}$

$V_{Rd} = 712.21 \text{ kN}$

## 4. Stiffness calculation

### 4.1. Design rotational stiffness

Sj data		
*Student version* *Student version* *Student version*		
Sj	55.14	MNm/rad
Sj,ini	87.38	MNm/rad
z	503.65	mm
mu	1.58	
k1	42.02	mm
k2	-	
keq	1.71	mm

### 4.2. Stiffness classification

Not applicable.

### 4.3 Check of stiffness requirement

Not applicable.

### 4.4 Ductility classification

The failure mode is not situated in the column shear zone.

In the endplate we have the following :

$t \leq 0.36 \sqrt{f_{ub}/f_y} d$

This results in a ductile classification for ductility : class 1.

## 5. Unity checks

Unity checks	
*Student version* *Student version* *Student version*	
M <sub>Sd</sub> /M <sub>jRd</sub>	0.79
V <sub>Sd</sub> /V <sub>Rd</sub>	0.08
Unity check M/M <sub>Rd</sub> + N/N <sub>Rd</sub>	0.81

The connection satisfies.

## 6. Design calculations

data		
*Student version* *Student version* *Student version*		
af	7.00	mm
aw	4.00	mm
Minimum th	4.65	mm

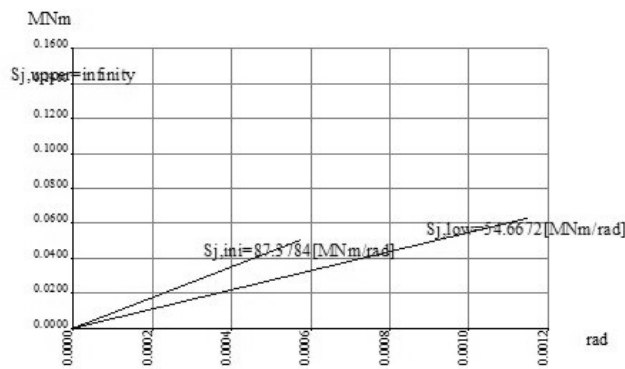
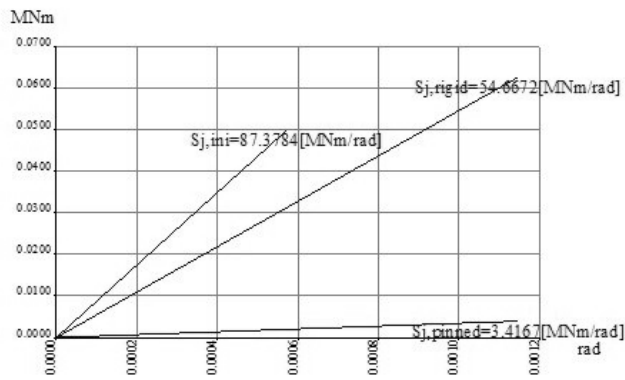
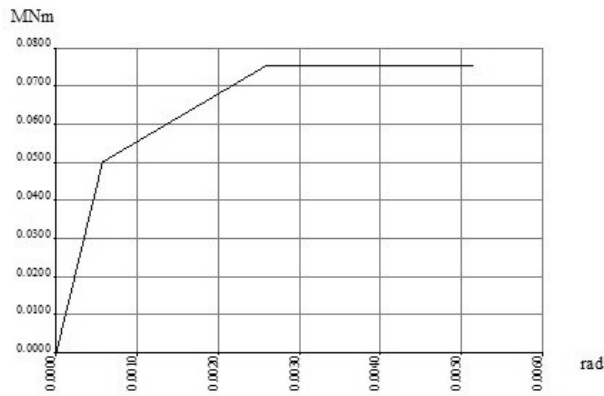

Type Name	Bolts
Internal bolts distance [mm]	100
External bolts distance [mm]	80
Selected bolt assembly	M27 - 10.9
Length [mm]	70
1.Location [mm]	520
2.Location [mm]	420
3.Location [mm]	320
4.Location [mm]	170
5.Location [mm]	80
Bolt pattern	2 bolts/row
*Student version* *Student version* *Student version* *Student version* *Student version* *Student version* *Student version* *Student version* *Student version*	Bolt assembly M27 - 10.9 M27 - DIN 6914 M27 - DIN 6916 M27 - DIN 6915 ✓ ✓ 10 10.9

Bolt assembly	Normal 200										
Bolts	Type Name	Name	Bore hole [mm]	Diameter required for bolt key [mm]	Head diameter [mm]	Diagonal head diameter [mm]	Head height [mm]	Gross cross-section area [mm <sup>2</sup> ]	Tensile stress area [mm <sup>2</sup> ]	Diameter [mm]	
	*Student version*	*Student version*	*Student version*	*Student version*	*Student version*	*Student version*	*Student version*	*Student version*	*Student version*	*Student version*	*Student version*
Nut	Type Name	Nut									
Washer	Name	M27 - DIN 6915									
	Diameter [mm]	46									
	Diagonal diameter [mm]	51									
	Height [mm]	22									
Washer	Type Name	Washer									
	Name	M27 - DIN 6916									
	Internal diameter [mm]	28									
	External diameter [mm]	50									
	Thickness [mm]	5									

Name	End4
Material	S 355
Thickness[mm]	12
Top [mm]	10
Bottom [mm]	10
Left [mm]	65
Right [mm]	65
Width [mm]	300
Height [mm]	600

Type Name	Name	Type	Input type	Height [m]	Thickness [m]	Angle [deg]
*Student version*	*Student version*	*Student version*	*Student version*	*Student version*	*Student version*	*Student version*
CadHaunch	CadHaunch2	Plate	Height x angle	0,220	0,010	60,00

Haunch underPlate		
*Student version*	*Student version*	*Student version*
hc	201.37	mm
lc	500.00	mm
tw	10.00	mm
weld awc	3.00	mm

Partial safety factors	
*Student version*	*Student version*
Gamma M0	1.00
Gamma M1	1.00
Gamma M2	1.25
Gamma M3	1.25

### 1. Internal forces

NC1		
*Student version*	*Student version*	
N	-0.75	kN
Vz	-59.46	kN
My	-66.85	kNm

Tension top

### 2. Design moment resistance MRd

#### 2.1. Design resistance of basic components

For individual bolt row :

$$Bt,Rd = 330.48 \text{ kN}$$

row	(Ft,fc,Rd)	Ft,ep,Rd
*Student version*	*Student version*	*Student version*
1	401.99	321.20
2	201.00	321.20
3	201.00	321.20
4	201.00	321.20
5	401.99	321.20

$N_{j,Rd} = 149.47 \text{ kN}$

data		
*Student version* *Student version* *Student version* *Student version* *Student version*		
Column web in compression (Fc,wc,Rd)	149.47	kN
Beam flange in compression (Fc,fb,Rd)	298.94	kN

data		
*Student version* *Student version* *Student version* *Student version* *Student version*		
Column web in shear (Vwp,Rd)	837.21	kN
Column web in compression (Fc,wc,Rd)	149.47	kN
Fc,h,Rd	149.47	kN

## 2.2. Determination of $M_{j,Rd}$

row	h[mm]	Ft[kN]
*Student version* *Student version* *Student version*		
1	503.65	149.47
2	403.65	0.00
3	303.65	0.00
4	153.65	0.00
5	63.65	0.00

$M_{j,Rd} = 75.28 \text{ kNm}$

## 2.3. Determination of $M_{j,Rd}$ for compressed haunch at beam

data		
*Student version* *Student version*		
$M_{j,Rd}$	82.97	kNm
MEd	-9.25	kNm

## 3. Design shear resistance $V_{Rd}$

$V_{Rd} = 712.21 \text{ kN}$

## 4. Stiffness calculation

### 4.1. Design rotational stiffness

Sj data		
*Student version* *Student version* *Student version*		
Sj	40.47	MNm/rad
Sj,ini	87.75	MNm/rad
z	503.65	mm
mu	2.17	
k1	47.20	mm
k2	-	
keq	1.71	mm

### 4.2. Stiffness classification

Not applicable.

### 4.3 Check of stiffness requirement

Not applicable.

### 4.4 Ductility classification

The failure mode is not situated in the column shear zone.

In the endplate we have the following :

$$t \leq 0.36 \sqrt{f_{ub}/f_y} d$$

This results in a ductile classification for ductility : class 1.

## 5. Unity checks

Unity checks	
*Student version* *Student version* *Student version*	
$M_{Sd}/M_{j,Rd}$	0.89
$V_{Sd}/V_{Rd}$	0.08
Unity check $M/M_{Rd} + N/N_{Rd}$	0.89

The connection satisfies.

## 6. Design calculations

data		
*Student version* *Student version* *Student version*		
af	7.00	mm
aw	4.00	mm
*Student version* *Student version* *Student version*		



External bolts distance [mm]	80																														
Selected bolt assembly	M27 - 10.9																														
Length [mm]	70																														
1.Location [mm]	650																														
2.Location [mm]	540																														
3.Location [mm]	430																														
4.Location [mm]	320																														
5.Location [mm]	190																														
6.Location [mm]	90																														
Bolt pattern	2 bolts/row																														
Bolt assembly	Bolt assembly M27 - 10.9 M27 - DIN 6914 M27 - DIN 6916 M27 - DIN 6915 ✓ ✓ 10 10.9 Normal 200 1000,0																														
Bolts	<table border="1"> <thead> <tr><th>Type Name</th><th>Name</th><th>Bore hole [mm]</th><th>Diameter required for bolt key [mm]</th><th>Head diameter [mm]</th><th>Diagonal head diameter [mm]</th><th>Head height [mm]</th><th>Gross cross-section area [mm²]</th><th>Tensile stress area [mm²]</th><th>Diameter [mm]</th></tr> </thead> <tbody> <tr><td>*Student version*</td><td>*Student version*</td><td>*Student version*</td><td>*Student version*</td><td>*Student version*</td><td>*Student version*</td><td>*Student version*</td><td>*Student version*</td><td>*Student version*</td><td>*Student version*</td></tr> <tr><td>Bolts</td><td>M27 - DIN 6914</td><td>30</td><td>120</td><td>46</td><td>51</td><td>17</td><td>573</td><td>459</td><td>27</td></tr> </tbody> </table>	Type Name	Name	Bore hole [mm]	Diameter required for bolt key [mm]	Head diameter [mm]	Diagonal head diameter [mm]	Head height [mm]	Gross cross-section area [mm²]	Tensile stress area [mm²]	Diameter [mm]	*Student version*	*Student version*	*Student version*	*Student version*	*Student version*	*Student version*	*Student version*	*Student version*	*Student version*	*Student version*	Bolts	M27 - DIN 6914	30	120	46	51	17	573	459	27
Type Name	Name	Bore hole [mm]	Diameter required for bolt key [mm]	Head diameter [mm]	Diagonal head diameter [mm]	Head height [mm]	Gross cross-section area [mm²]	Tensile stress area [mm²]	Diameter [mm]																						
*Student version*	*Student version*	*Student version*	*Student version*	*Student version*	*Student version*	*Student version*	*Student version*	*Student version*	*Student version*																						
Bolts	M27 - DIN 6914	30	120	46	51	17	573	459	27																						
Nut	<table border="1"> <thead> <tr><th>Type Name</th><th>Name</th></tr> </thead> <tbody> <tr><td>Nut</td><td>M27 - DIN 6915</td></tr> <tr><td>Diameter [mm]</td><td>46</td></tr> <tr><td>Diagonal diameter [mm]</td><td>51</td></tr> <tr><td>Height [mm]</td><td>22</td></tr> </tbody> </table>	Type Name	Name	Nut	M27 - DIN 6915	Diameter [mm]	46	Diagonal diameter [mm]	51	Height [mm]	22																				
Type Name	Name																														
Nut	M27 - DIN 6915																														
Diameter [mm]	46																														
Diagonal diameter [mm]	51																														
Height [mm]	22																														
Washer	<table border="1"> <thead> <tr><th>Type Name</th><th>Name</th></tr> </thead> <tbody> <tr><td>Washer</td><td>M27 - DIN 6916</td></tr> <tr><td>Internal diameter [mm]</td><td>28</td></tr> <tr><td>External diameter [mm]</td><td>50</td></tr> <tr><td>Thickness [mm]</td><td>5</td></tr> </tbody> </table>	Type Name	Name	Washer	M27 - DIN 6916	Internal diameter [mm]	28	External diameter [mm]	50	Thickness [mm]	5																				
Type Name	Name																														
Washer	M27 - DIN 6916																														
Internal diameter [mm]	28																														
External diameter [mm]	50																														
Thickness [mm]	5																														

Name	End7
Material	S 355
Thickness[mm]	12
Top [mm]	0
Bottom [mm]	20
Left [mm]	50
Right [mm]	50
Width [mm]	300
Height [mm]	740

Name	Sti5
Material	S 355
Decrease [mm]	1
Thickness[mm]	10
*Student version* *Student version* *Student version*	
Name	Sti6
Material	S 355
Decrease [mm]	1
Thickness[mm]	10

Type Name	Name	Type	Input type	Height [m]	Thickness [m]	Angle [deg]
*Student version* *Student version* *Student version* *Student version* *Student version* *Student version* *Student version*						*Student version*
CadHaunch	CadHaunch3	Plate	Height x angle	0,220	0,010	60,00

Name	Web doubler2
Thickness[mm]	6
Material	S 355
Size of web doubler	Large
Type of web doubler	Double
Width [mm]	243
Height [mm]	848

According to EN 1993-1-8

Haunch underPlate		
*Student version* *Student version* *Student version* *Student version*		
hc	201.37	mm
lc	500.00	mm
tw	10.00	mm
weld awc	3.00	mm

Partial safety factors	
*Student version* *Student version* *Student version*	
Gamma M0	1.00
Gamma M1	1.00
Gamma M2	1.25
Gamma M3	1.25

### 1. Internal forces

NC1		
*Student version* *Student version*		
N	-13.61	kN
Vz	58.86	kN
My	-68.21	kNm

Tension top

### 2. Design moment resistance MRd

#### 2.1. Design resistance of basic components

For individual bolt row :

$$B_t, R_d = 330.48 \text{ kN}$$

row	(Ft,fc,Rd)	Ft,ep,Rd
*Student version* *Student version* *Student version*		
1	401.99	321.20
2	201.00	321.20
3	201.00	321.20
4	201.00	321.20
5	201.00	321.20
6	401.99	321.20

$$N_j, R_d = 149.47 \text{ kN}$$

data		
*Student version* *Student version* *Student version* *Student version* *Student version*		
Column web in compression (Fc,wc,Rd)	149.47	kN
Beam flange in compression (Fc,fb,Rd)	298.94	kN

data		
*Student version* *Student version* *Student version* *Student version* *Student version*		
Column web in shear (Vwp,Rd)	837.21	kN
Column web in compression (Fc,wc,Rd)	149.47	kN
Fc,h,Rd	149.47	kN

#### 2.2. Determination of $M_j, R_d$

row	h[mm]	Ft[kN]
*Student version* *Student version* *Student version*		
1	622.00	149.47
2	512.00	0.00
3	402.00	0.00
4	292.00	0.00
5	162.00	0.00
6	62.00	0.00

$$M_j, R_d = 92.97 \text{ kNm}$$

#### 2.3. Determination of $M_j, R_d$ for compressed haunch at beam

data		
*Student version* *Student version* *Student version*		
$M_j, R_d$	119.43	kNm
MEd	-20.87	kNm

### 3. Design shear resistance VRd

$$V_{Rd} = 1034.20 \text{ kN}$$

### 4. Stiffness calculation



#### 4.1. Design rotational stiffness

Sj data		
*Student version* *Student version* *Student version*		
Sj	111.74	MNm/rad
Sj,ini	144.68	MNm/rad
z	622.00	mm
mu	1.29	
k1	39.36	mm
k2	-	
keq	1.87	mm

#### 4.2. Stiffness classification

Not applicable.

#### 4.3 Check of stiffness requirement

Not applicable.

#### 4.4 Ductility classification

The failure mode is not situated in the column shear zone.

In the endplate we have the following :

$$t \leq 0.36 \sqrt{(f_{ub}/f_y)} d$$

This results in a ductile classification for ductility : class 1.

#### 5. Unity checks

Unity checks	
*Student version* *Student version* *Student version*	
MSd/MjRd	0.73
VSd/VRd	0.06
Unity check M/MRd + N/Nrd	0.82

**The connection satisfies.**

#### 6. Design calculations

data		
*Student version* *Student version* *Student version*		
af	8.00	mm
aw	6.00	mm
Minimum th	3.93	mm

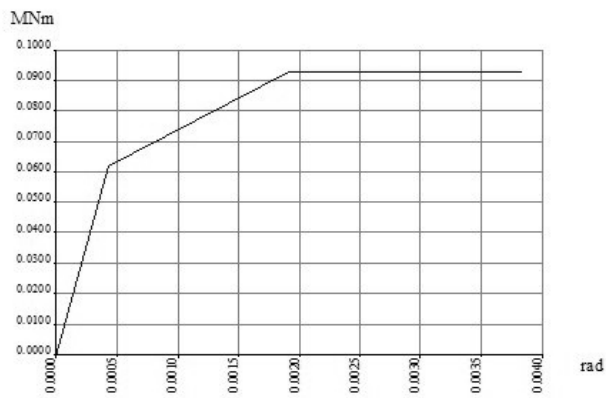

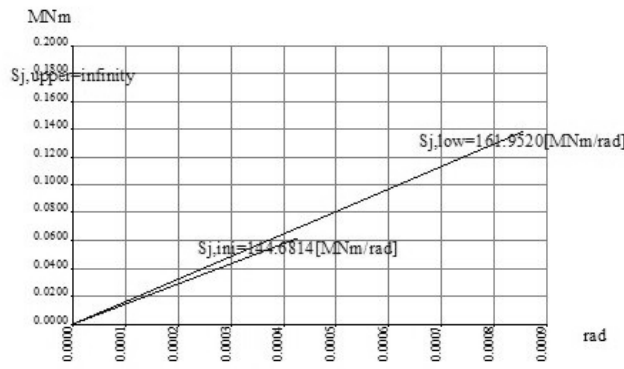
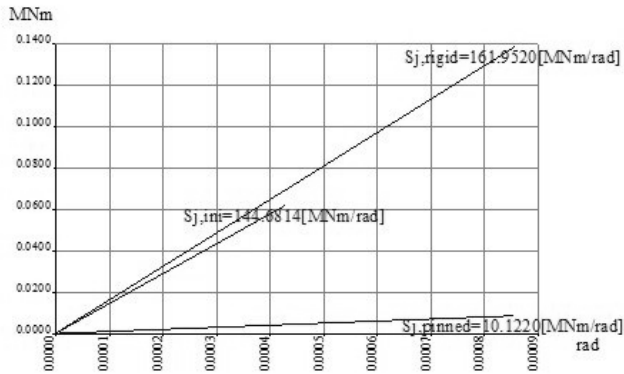

Type Name	Bolts										
Internal bolts distance [mm]	100										
External bolts distance [mm]	80										
Selected bolt assembly	M27 - 10.9										
Length [mm]	70										
1.Location [mm]	650										
2.Location [mm]	540										
3.Location [mm]	430										
4.Location [mm]	320										
5.Location [mm]	190										
6.Location [mm]	90										
Bolt pattern	2 bolts/row										
Bolt assembly	Bolt assembly M27 - 10.9 M27 - DIN 6914 M27 - DIN 6916 M27 - DIN 6915 ✓ ✓ 10 10.9 Normal 200 1000.0										
Bolts	Type Name	Name	Bore hole [mm]	Diameter required for bolt key [mm]	Head diameter [mm]	Diagonal head diameter [mm]	Head height [mm]	Gross cross-section area [mm <sup>2</sup> ]	Tensile stress area [mm <sup>2</sup> ]	Diameter [mm]	
	Bolts	M27 - DIN 6914	30	120	46	51	17	573	459	27	
Nut	Type Name	Nut									
	Name	M27 - DIN 6915									
	Diameter [mm]	46									
	Diagonal diameter [mm]	51									
	Height [mm]	22									
Washer	Type Name	Washer									
	Name	M27 - DIN 6916									
	Internal diameter [mm]	28									
	External diameter [mm]	50									
	Thickness [mm]	5									

\*Student version\* \*Student version\* \*Student version\* \*Student version\* \*Student version\* \*Student version\* \*Student version\*

Name	End8
Material	S 355
Thickness[mm]	12
Top [mm]	0
Bottom [mm]	20
Left [mm]	50
Right [mm]	50
Width [mm]	300
Height [mm]	740

Type	Name	Type	Input type	Height [m]	Thickness [m]	Angle [deg]
*Student version*	*Student version*	*Student version*	*Student version*	*Student version*	*Student version*	*Student version*
According to EN 1993-1-4	End8	Plate	Height x angle	0,220	0,010	60,00

Haunch under Plate		
*Student version*	*Student version*	*Student version*
hc	201.37	mm
lc	500.00	mm
tw	10.00	mm
weld awc	3.00	mm

Partial safety factors	
*Student version*	*Student version*
Gamma M0	1.00
Gamma M1	1.00
Gamma M2	1.25
Gamma M3	1.25

### 1. Internal forces

NC1		
*Student version*	*Student version*	
N	-16.77	kN
Vz	-69.85	kN
My	-75.46	kNm

Tension top

### 2. Design moment resistance MRd

#### 2.1. Design resistance of basic components

For individual bolt row :

$$B_t, R_d = 330.48 \text{ kN}$$

row	(Ft,fc,Rd)	Ft,ep,Rd
*Student version*	*Student version*	*Student version*
1	401.99	321.20
2	201.00	321.20
3	201.00	321.20
4	201.00	321.20
5	201.00	321.20
6	401.99	321.20

$$N_j, R_d = 149.47 \text{ kN}$$

data		
*Student version*	*Student version*	*Student version*
Column web in compression (Fc,wc,Rd)	149.47	kN
Beam flange in compression (Fc,fb,Rd)	298.94	kN

data		
*Student version*	*Student version*	*Student version*
Column web in shear (Vwp,Rd)	837.21	kN
Column web in compression (Fc,wc,Rd)	149.47	kN
Fc,h,Rd	149.47	kN

#### 2.2. Determination of Mj ,Rd

row	h[mm]	Ft[kN]
*Student version*	*Student version*	*Student version*
1	622.00	149.47
*Student version*	*Student version*	*Student version*

row	h[mm]	Ft[kN]
*Student version*	*Student version*	*Student version*
2	512.00	0.00
3	402.00	0.00
4	292.00	0.00
5	162.00	0.00
6	62.00	0.00

$M_{j,Rd} = 92.97 \text{ kNm}$

### 2.3. Determination of $M_{j,Rd}$ for compressed haunch at beam

data		
*Student version*	*Student version*	*Student version*
$M_{j,Rd}$	119.43	kNm
$M_{Ed}$	16.66	kNm

### 3. Design shear resistance $V_{Rd}$

$V_{Rd} = 1034.20 \text{ kN}$

### 4. Stiffness calculation

#### 4.1. Design rotational stiffness

Sj data		
*Student version*	*Student version*	*Student version*
Sj	85.41	MNm/rad
Sj,ini	145.31	MNm/rad
z	622.00	mm
mu	1.70	
k1	43.55	mm
k2	-	
keq	1.87	mm

#### 4.2. Stiffness classification

Not applicable.

#### 4.3 Check of stiffness requirement

Not applicable.

#### 4.4 Ductility classification

The failure mode is not situated in the column shear zone.

In the endplate we have the following :

$$t \leq 0.36 \sqrt{f_{ub}/f_y} d$$

This results in a ductile classification for ductility : class 1.

### 5. Unity checks

Unity checks	
*Student version*	*Student version*
$M_{Sd}/M_{j,Rd}$	0.81
$V_{Sd}/V_{Rd}$	0.07
Unity check $M/M_{Rd} + N/N_{Rd}$	0.92

The connection satisfies.

### 6. Design calculations

data		
*Student version*	*Student version*	*Student version*
af	8.00	mm
aw	6.00	mm
Minimum th	3.93	mm



3.Location [mm]	430																				
4.Location [mm]	320																				
5.Location [mm]	190																				
6.Location [mm]	90																				
Bolt pattern	2 bolts/row																				
Bolt assembly	Bolt assembly M27 - 10.9 M27 - DIN 6914 M27 - DIN 6916 M27 - DIN 6915 ✓ ✓ 10 10.9 Normal 200 1000,0																				
Bolts	<table border="1"> <thead> <tr> <th>Type Name</th> <th>Name</th> <th>Bore hole [mm]</th> <th>Diameter required for bolt key [mm]</th> <th>Head diameter [mm]</th> <th>Diagonal head diameter [mm]</th> <th>Head height [mm]</th> <th>Gross cross-section area [mm<sup>2</sup>]</th> <th>Tensile stress area [mm<sup>2</sup>]</th> <th>Diameter [mm]</th> </tr> </thead> <tbody> <tr> <td>Bolts</td> <td>M27 - DIN 6914</td> <td>30</td> <td>120</td> <td>46</td> <td>51</td> <td>17</td> <td>573</td> <td>459</td> <td>27</td> </tr> </tbody> </table>	Type Name	Name	Bore hole [mm]	Diameter required for bolt key [mm]	Head diameter [mm]	Diagonal head diameter [mm]	Head height [mm]	Gross cross-section area [mm <sup>2</sup> ]	Tensile stress area [mm <sup>2</sup> ]	Diameter [mm]	Bolts	M27 - DIN 6914	30	120	46	51	17	573	459	27
Type Name	Name	Bore hole [mm]	Diameter required for bolt key [mm]	Head diameter [mm]	Diagonal head diameter [mm]	Head height [mm]	Gross cross-section area [mm <sup>2</sup> ]	Tensile stress area [mm <sup>2</sup> ]	Diameter [mm]												
Bolts	M27 - DIN 6914	30	120	46	51	17	573	459	27												
Nut	<table border="1"> <thead> <tr><th>Type Name</th><th>Name</th><th>Diameter [mm]</th><th>Diagonal diameter [mm]</th><th>Height [mm]</th></tr> </thead> <tbody> <tr><td></td><td></td><td>M27 - DIN 6915</td><td>46</td><td>51</td></tr> <tr><td></td><td></td><td></td><td></td><td>22</td></tr> </tbody> </table>	Type Name	Name	Diameter [mm]	Diagonal diameter [mm]	Height [mm]			M27 - DIN 6915	46	51					22					
Type Name	Name	Diameter [mm]	Diagonal diameter [mm]	Height [mm]																	
		M27 - DIN 6915	46	51																	
				22																	
Washer	<table border="1"> <thead> <tr><th>Type Name</th><th>Name</th><th>Internal diameter [mm]</th><th>External diameter [mm]</th><th>Thickness [mm]</th></tr> </thead> <tbody> <tr><td>Washer</td><td></td><td>M27 - DIN 6916</td><td>28</td><td>50</td></tr> <tr><td></td><td></td><td></td><td></td><td>5</td></tr> </tbody> </table>	Type Name	Name	Internal diameter [mm]	External diameter [mm]	Thickness [mm]	Washer		M27 - DIN 6916	28	50					5					
Type Name	Name	Internal diameter [mm]	External diameter [mm]	Thickness [mm]																	
Washer		M27 - DIN 6916	28	50																	
				5																	

Name	End9
Material	S 355
Thickness[mm]	12
Top [mm]	0
Bottom [mm]	20
Left [mm]	40
Right [mm]	40
Width [mm]	280
Height [mm]	740

Name	Sti7
Material	S 355
Decrease [mm]	1
Thickness[mm]	10
Name	Sti8
Material	S 355
Decrease [mm]	1
Thickness[mm]	10

Type Name	Name	Type	Input type	Height [m]	Thickness [m]	Angle [deg]

CadHaunch	CadHaunch5	Plate	Height x angle	0,220	0,010	60,00
Name	Web doubler3					
Thickness[mm]	6					
Material	S 355					
Size of web doubler	Large					
Type of web doubler	Double					
Width [mm]	196					
Height [mm]	822					

According to EN 1993-1-8

Haunch underPlate	
hc	201.37 mm

Haunch underPlate		
lc	500.00	mm
tw	10.00	mm
weld_ awc	3.00	mm

Partial safety factors		
Gamma M0	1.00	
Gamma M1	1.00	
Gamma M2	1.25	
Gamma M3	1.25	

### 1. Internal forces

NC1		
N	-16.74	kN
Vz	48.44	kN
My	-21.91	kNm

Tension top

### 2. Design moment resistance MRd

#### 2.1. Design resistance of basic components

For individual bolt row :

Bt,Rd = 330.48 kN

row	(Ft,fc,Rd)	Ft,ep,Rd
1	249.54	321.20
2	249.54	321.20
3	249.54	321.20
4	249.54	321.20
5	249.54	321.20
6	249.54	321.20

Nj,Rd = 149.47 kN

data	
Column web in compression (Fc,wc,Rd)	1
Beam flange in compression (Fc,fb,Rd)	2

data	
Column web in shear (Vwp,Rd)	5
Column web in compression (Fc,wc,Rd)	1
Fc,h,Rd	1

#### 2.2. Determination of Mj ,Rd

row	h[mm]	Ft[kN]
1	622.00	149.47
2	512.00	0.00
3	402.00	0.00
4	292.00	0.00
5	162.00	0.00
6	62.00	0.00

Mj,Rd = 92.97 kNm

#### 2.3. Determination of Mj ,Rd for compre

data		
Mj,Rd	119.43	kNm
MEd	15.62	kNm

### 3. Design shear resistance VRd

VRd = 1034.20 kN

### 4. Stiffness calculation

#### 4.1. Design rotational stiffness

Sj data		
*Student version* *Student version* *Student version*		
Sj	91.28	MNm/rad
Sj,ini	91.28	MNm/rad
z	622.00	mm
mu	1.00	
k1	2.90	mm
k2	-	
keq	1.83	mm

#### 4.2. Stiffness classification

Not applicable.

#### 4.3 Check of stiffness requirement

Not applicable.

#### 4.4 Ductility classification

The failure mode is not situated in the column shear zone.

In the endplate we have the following :

$$t \leq 0.36 \sqrt{f_{ub}/f_y} d$$

This results in a ductile classification for ductility : class 1.

#### 5. Unity checks

Unity checks	
*Student version* *Student version* *Student version*	
MSd/MjRd	0.24
VSd/VRd	0.05
Unity check M/MRd + N/Nrd	0.35

**The connection satisfies.**

#### 6. Design calculations

data		
*Student version* *Student version* *Student version*		
af	8.00	mm
aw	6.00	mm
Minimum th	3.93	mm

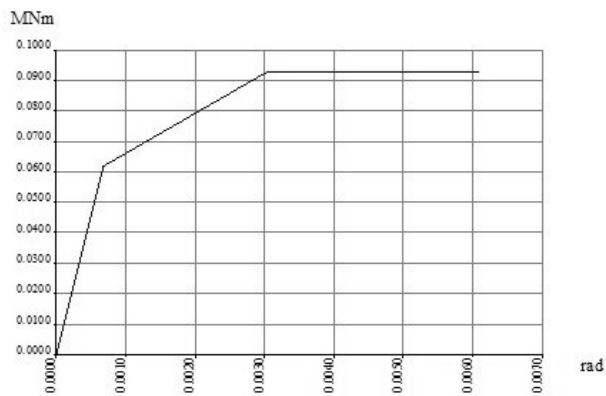



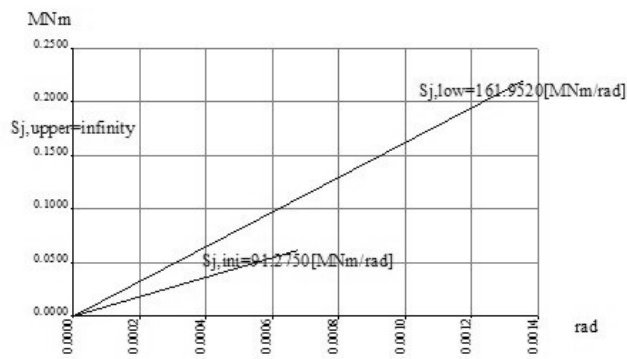
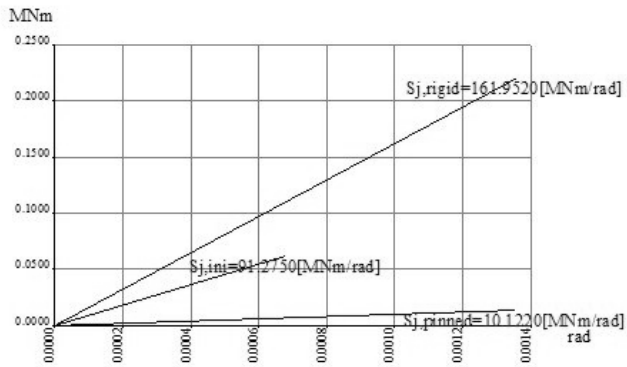

\*Student version\* \*Student version\* \*Student version\* \*Student version\* \*Student version\* \*Student version\* \*Student version\* \*Student version\* \*Student version\* \*Student version\*

Spoj 5

N292

Grid pinned

Grid

Name	CrossSection	Length [m]	Shape	Beg. node	End node	Type	FEM type	Layer
B24	CS2 - IPE330	5,000	Line	N19	N20	beam (80)	standard	prečka
B508	CS3 - IPE270	5,000	Line	N295	N292	beam (80)	standard	sek preč
B505	CS3 - IPE270	5,000	Line	N292	N289	beam (80)	standard	sek preč

Bolts

Bol

M16 - 10.9

32

32

36

36

1

3

Bolt assembly

M16 - 10.9

M16 - DIN 6914

M16 - DIN 6916

M16 - DIN 6915

✓

✓

10

10.9

1000,0

Normal

200

Type Name	Name	Bore hole [mm]	Diameter required for bolt key [mm]	Head diameter [mm]	Diagonal head diameter [mm]	Head height [mm]	Gross cross-section area [mm <sup>2</sup> ]	Tensile stress area [mm <sup>2</sup> ]	Diameter [mm]
*Student version* *Student version* *Student version* *Student version* *Student version* *Student version* *Student version* *Student version* *Student version* *Student version*									
Bolts	M16 - DIN 6914	18	80	27	30	10	201	157	16
Type Name	*Student version* *Student version* *Student version* *Student version* *Student version* *Student version* *Student version* *Student version* *Student version*								
Bolts	M16 - DIN 6914	18	80	27	30	10	201	157	16

Type Name	Washer								
Name	M16 - DIN 6916								
Internal diameter [mm]	17								
External diameter [mm]	30								
Thickness [mm]	4								

Type Name	Pinned plate								
Name	Pin								
Material	S 355								
Thickness[mm]	6								
B [mm]	72								
H [mm]	180								
P [mm]	30								
Distance between 2 connected profiles. [mm]	5								
Number of plates	2								

The limit capacities are according to EN 1993-1-8

Partial safety factors	
*Student version* *Student version* *Student version*	
Gamma M0	1.00
Gamma M1	1.00
Gamma M2	1.25
Gamma M3	1.25

#### 1. Internal forces

NC2		
*Student version* *Student version*		
N	0.67	kN
Vz	-60.24	kN
My	-0.00	kNm

#### 2. Design shear resistance

data		
*Student version* *Student version* *Student version* *Student version*		
VRd connection element	314.26	kN
VRd beam	299.75	kN
VRd for bolts in beam web	137.24	kN
VRd shear block	166.87	kN
VRd shear block	316.83	kN

#### 3. Design tension/compression resistance NRd

data		
*Student version* *Student version* *Student version* *Student version*		
NRd connection element	606.17	kN
NRd beam	1078.65	kN
NRd column web	72.40	kN

#### 4. Unity checks

Unity checks	
*Student version* *Student version*	
VsD/VRd	0.44
NSd/NRd	0.01

The connection satisfies.

#### 5. Weldsize calculation

<b>data</b>		
*Student version* *Student version* *Student version*		
Weldsize plate/column	3.00	mm

Bolts

Boll

M16 - 10.9

36  
36  
36  
36  
1  
3

Bolt assembly

M16 - 10.9

M16 - DIN 6914

M16 - DIN 6916

M16 - DIN 6915

✓

✓

10

10.9

1000,0

Normal

200

Type Name	Name	Bore hole [mm]	Diameter required for bolt key [mm]	Head diameter [mm]	Diagonal head diameter [mm]	Head height [mm]	Gross cross-section area [mm <sup>2</sup> ]	Tensile stress area [mm <sup>2</sup> ]	Diameter [mm]
*Student version* *Student version* *Student version* *Student version* *Student version* *Student version* *Student version* *Student version* *Student version* *Student version*									
Bolts	M16 - DIN 6914	18	80	27	30	10	201	157	16
*Student version* *Student version* *Student version* *Student version* *Student version* *Student version* *Student version* *Student version* *Student version* *Student version*									
Bolts	M16 - DIN 6914	18	80	27	30	10	201	157	16

<b>Type Name</b>		Washer
<b>Name</b>		M16 - DIN 6916
<b>Internal diameter [mm]</b>		17
<b>External diameter [mm]</b>		30
<b>Thickness [mm]</b>		4

<b>Type Name</b>	Pinned plate
<b>Name</b>	Pin1
<b>Material</b>	S 355
<b>Thickness[mm]</b>	6
<b>B [mm]</b>	72
<b>H [mm]</b>	180
<b>P [mm]</b>	30
<b>Distance between 2 connected profiles. [mm]</b>	5
<b>Number of plates</b>	2

The limit capacities are according to EN 1993-1-8

<b>Partial safety factors</b>	
*Student version* *Student version* *Student version*	
Gamma M0	1.00
Gamma M1	1.00
Gamma M2	1.25
Gamma M3	1.25

### 1.Internal forces

NC2		
*Student version* *Student version*		
N	0.59	kN
Vz	60.24	kN
*Student version* *Student version*		

NC2		
*Student version* *Student version*		
My	-0.00	kNm

## 2. Design shear resistance

data		
*Student version* *Student version* *Student version* *Student version*		
VRd connection element	314.26	kN
VRd beam	299.75	kN
VRd for bolts in beam web	120.67	kN
VRd shear block	136.42	kN
VRd shear block	307.00	kN

## 3, Design tension/compression resistance NRd

data		
*Student version* *Student version* *Student version* *Student version*		
NRd connection element	606.17	kN
NRd beam	1078.65	kN
NRd column web	72.40	kN

## 4. Unity checks

Unity checks	
*Student version* *Student version*	
V <sub>Sd</sub> /V <sub>Rd</sub>	0.50
N <sub>Sd</sub> /N <sub>Rd</sub>	0.01

The connection satisfies.

## 5. Weldsize calculation

data		
*Student version* *Student version* *Student version*		
Weldsize plate/column	3.00	mm

Sekereš, D. 2011. Statični izračun jeklenega trietažnega poslovnega objekta.

Dipl. nal. – VSŠ. Ljubljana, UL, FGG, Odd. za gradbeništvo, Konstrukcijska smer.

---

## **PRILOGA D: Pozicijski načrti in detajli**

Tloris temeljev

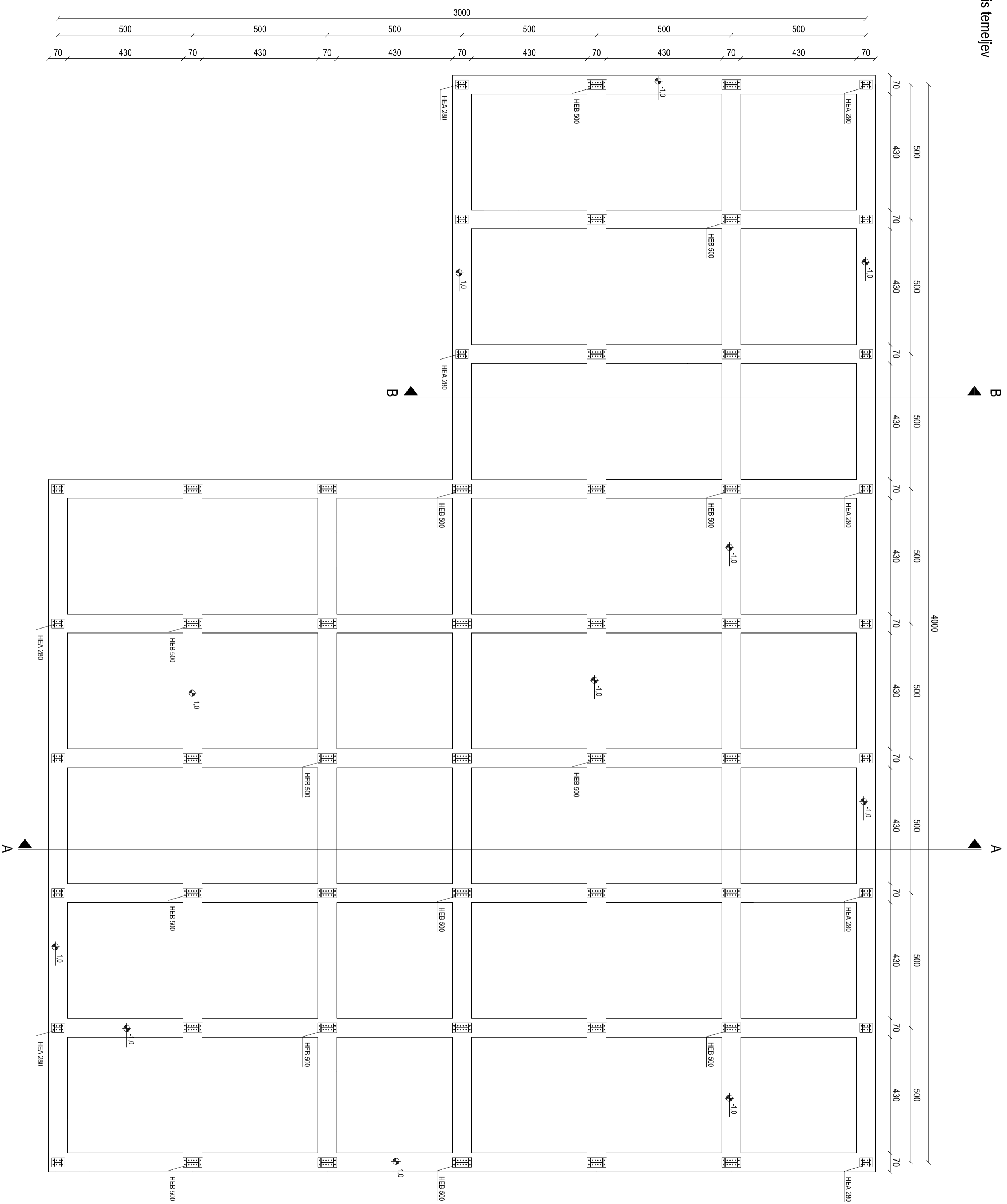

Legenda materialov  
 Armatirani beton  
 Jelo

TLORIS TEMELJEV



MERILO 1:100

Damjan Sekereš

april 2011

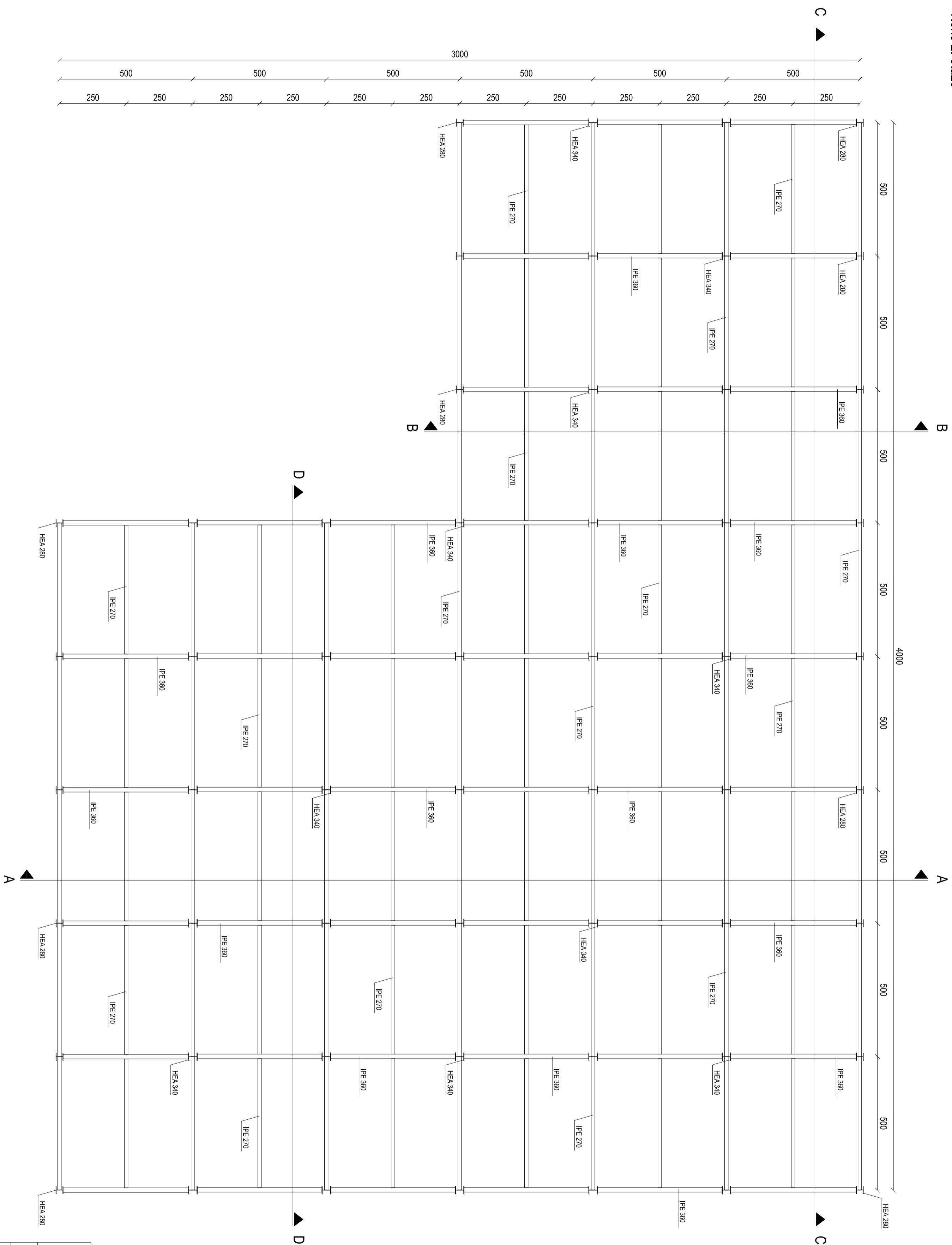
Tloris 2. etaže



Legenda materijalov  
 Armirani beton  
 Jelič

TLORIS 2. ETAŽE

MERILO 1:100

Damijan Sekereš

april 2011





Vzdolžni prerez C-C

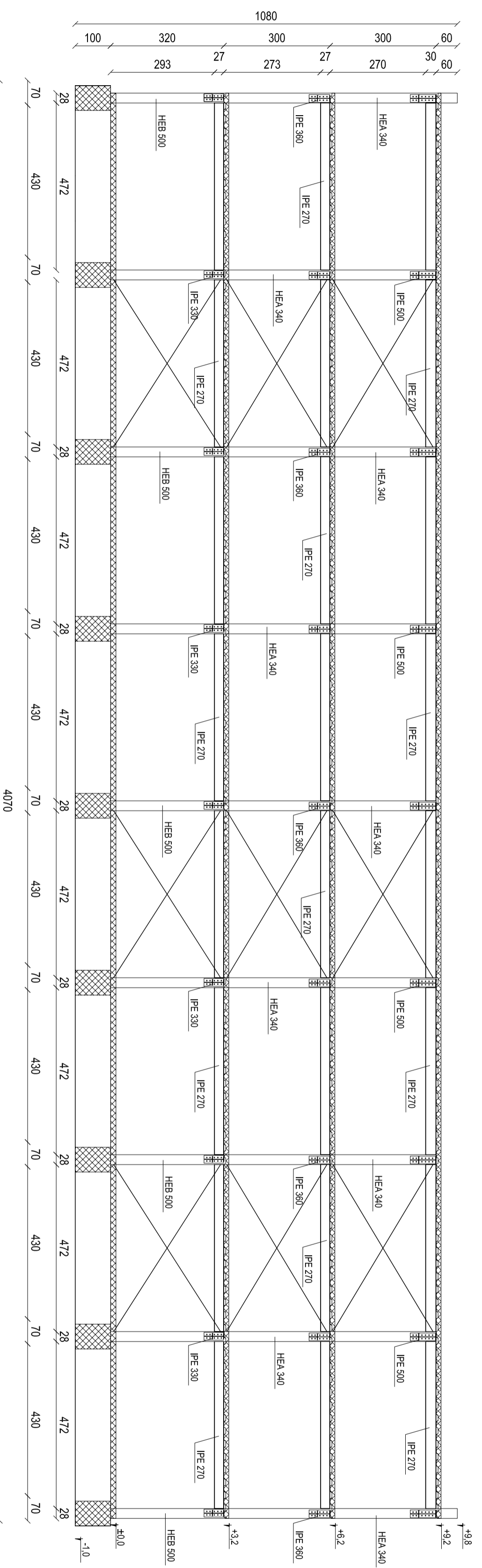

Vzdolžni prerez D-D

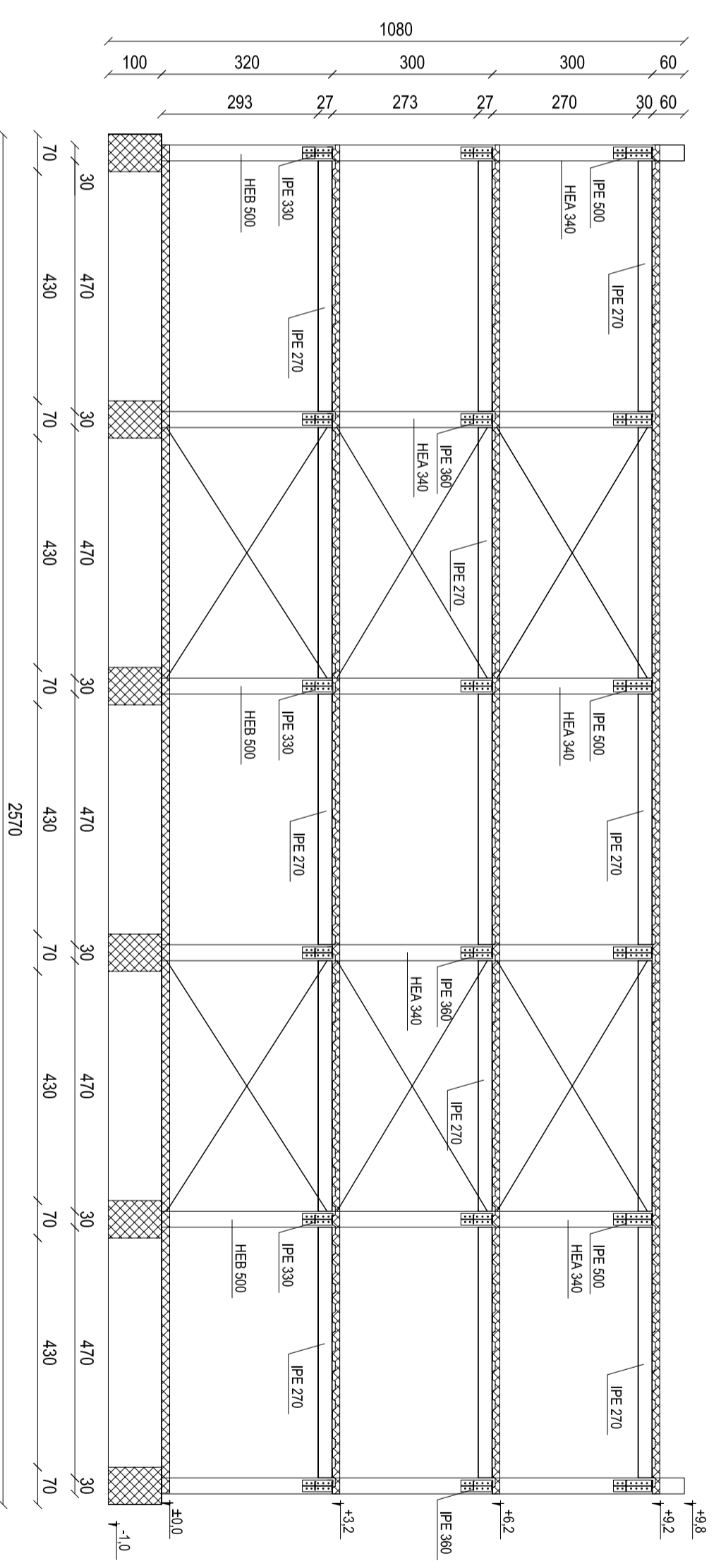

Legenda materijalov  
 Armirani beton  
 Jeklo

VZDOLŽNI PREREZ

MERILO 1:100

Damjan Sekereš

april 2011

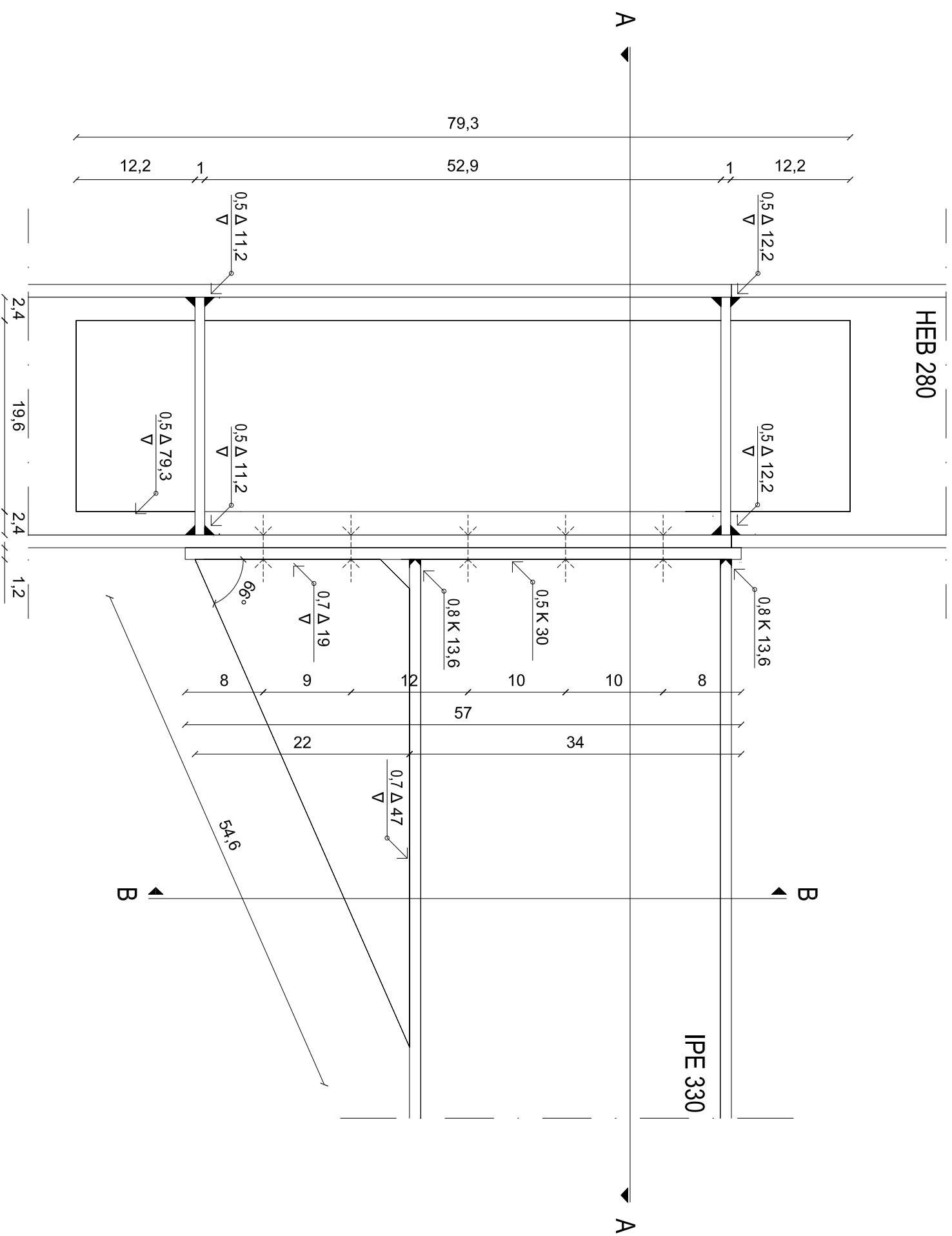

SPOJ PREČKE NA STEBER

MERILO 1:5

Damjan Sekereš

april 2011

Prerez B-B

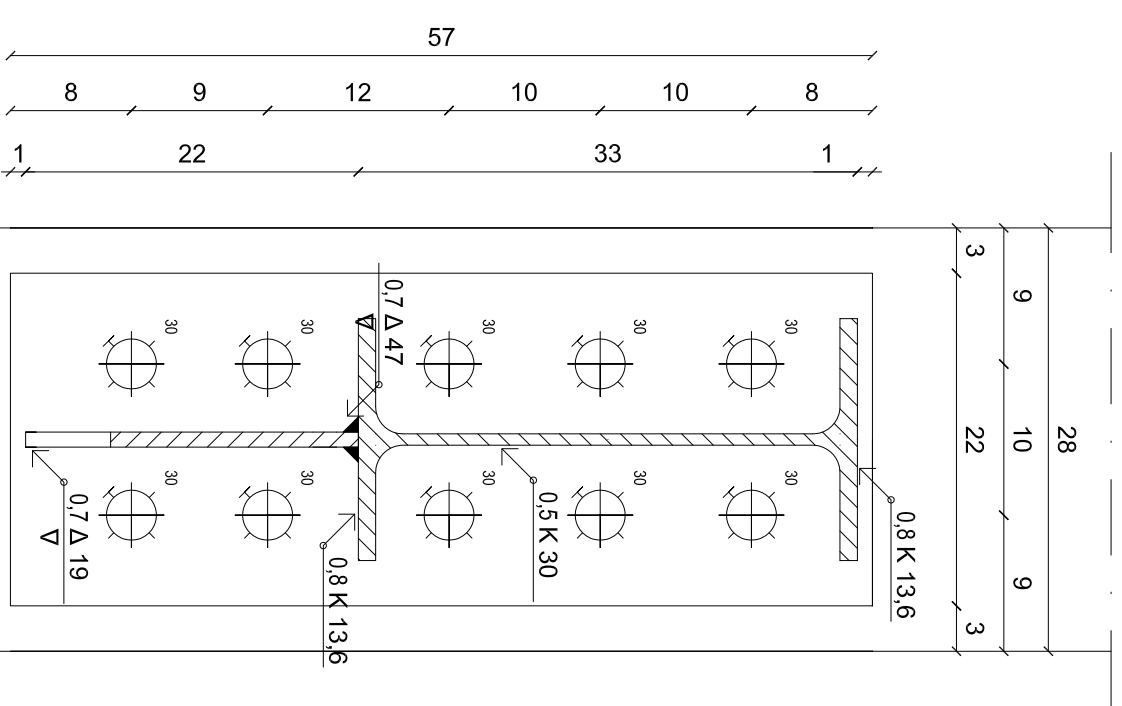

Prerez A-A

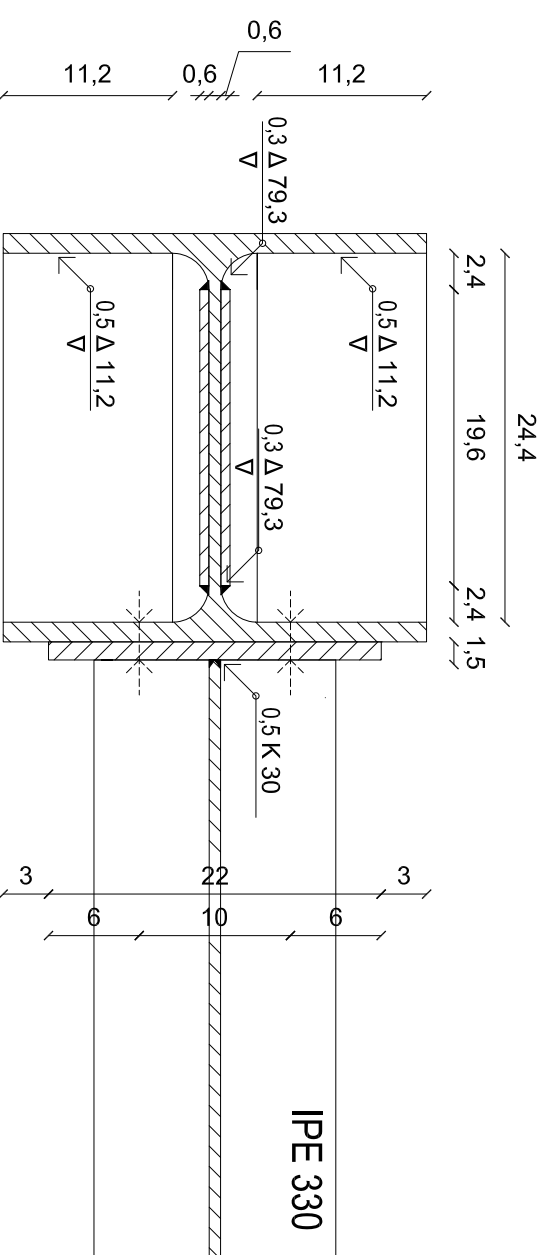

SPOJ PREČKE NA STEBER

MERILO 1:5

Damjan Sekereš

april 2011

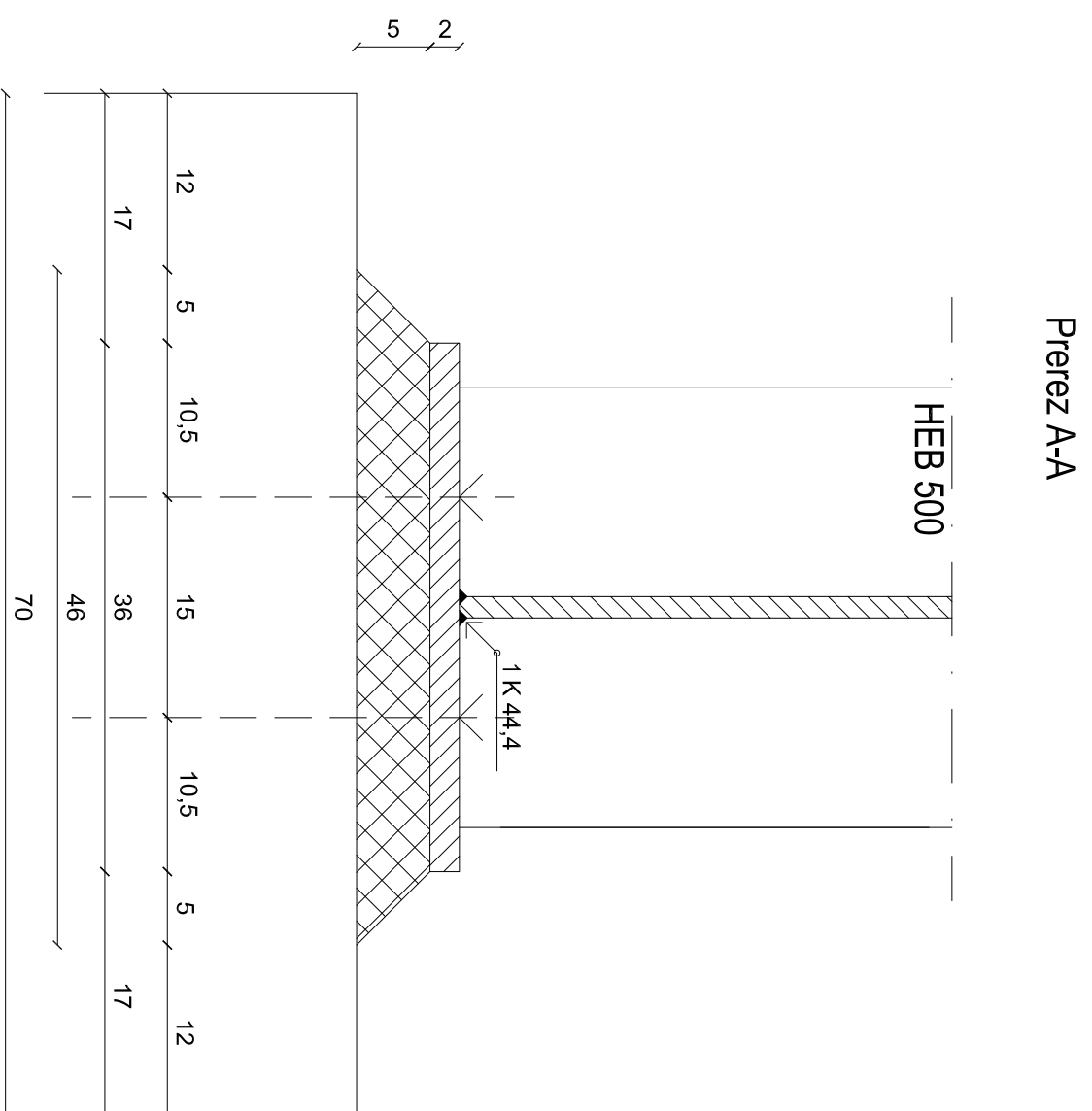
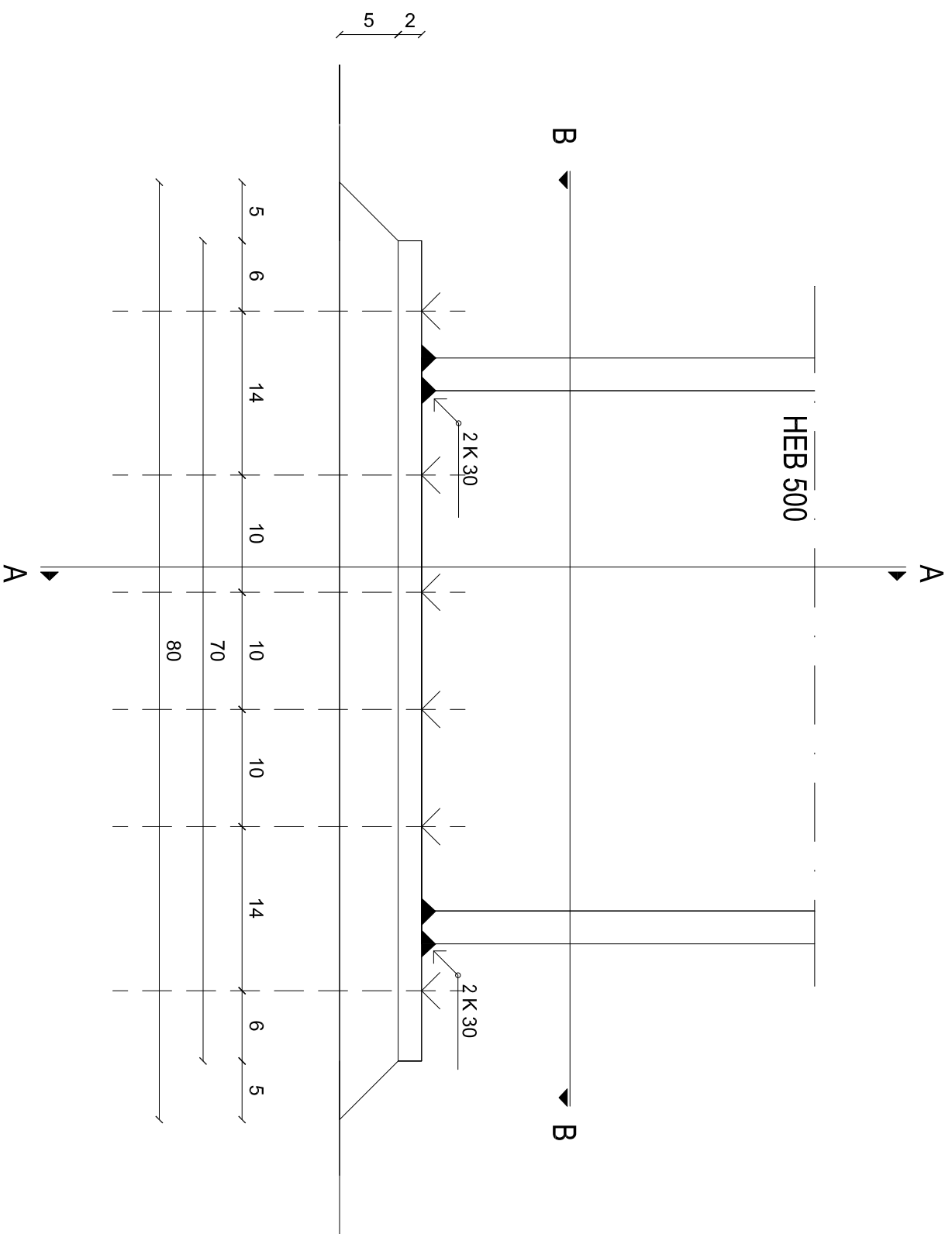

Prerez A-A

SPOJ STEBRA NA TEMELJU

MERILO 1:5

Damjan Sekereš

april 2011

Prerez B-B

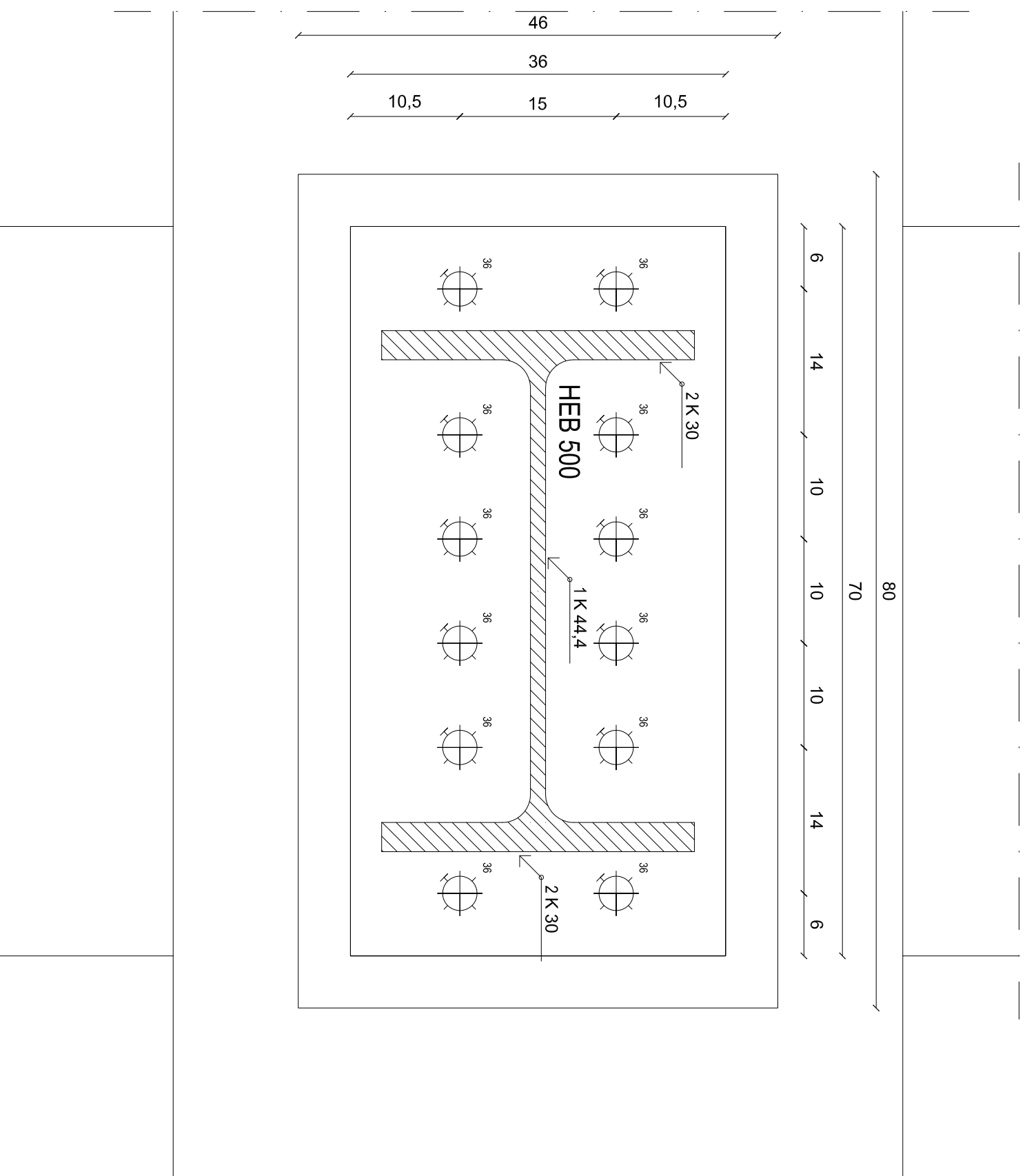

SPOJ STEBRA NA TEMELJU

MERILO 1:5

Damjan Sekereš

april 2011

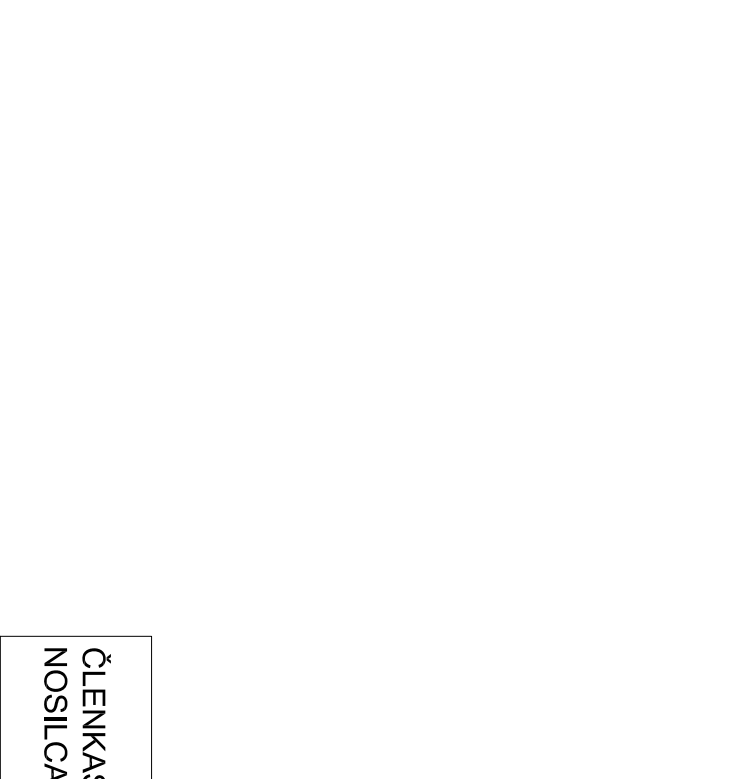
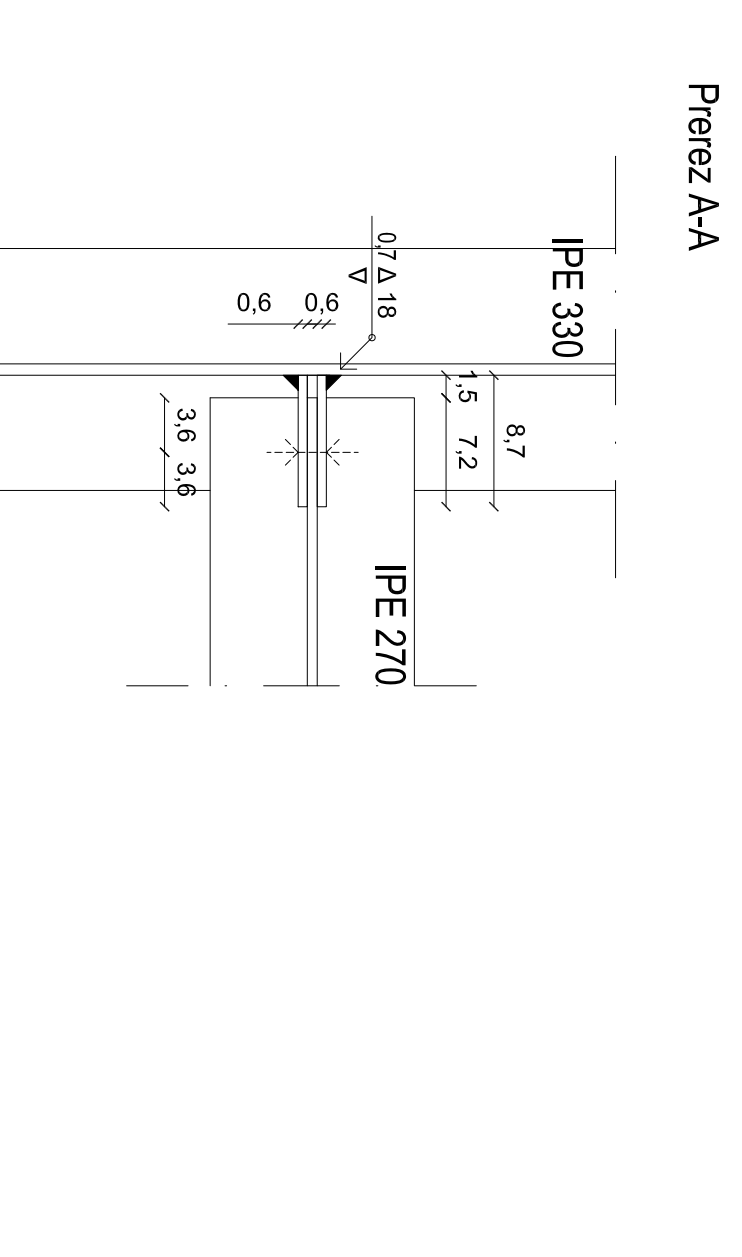
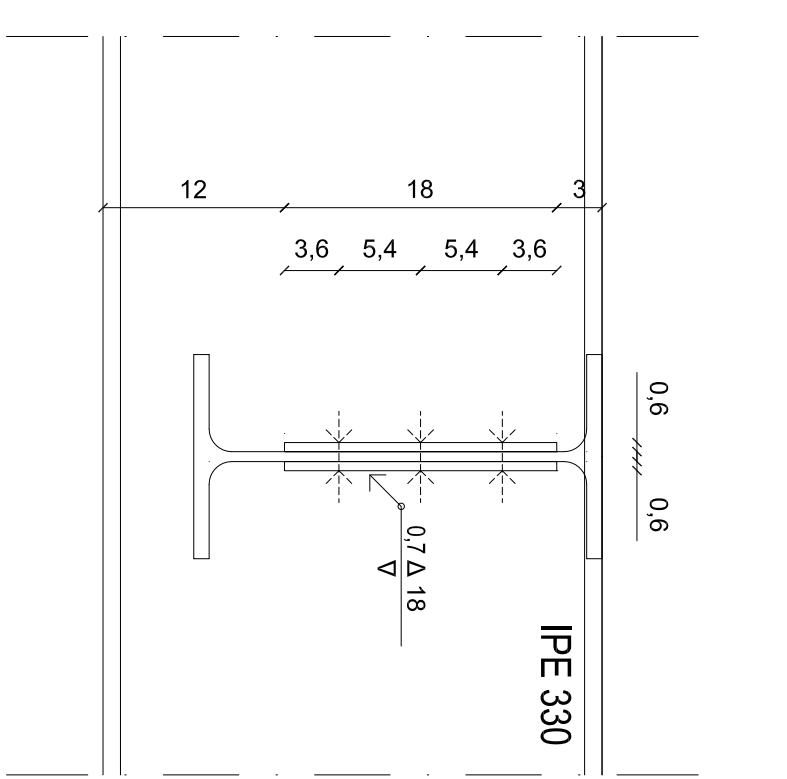
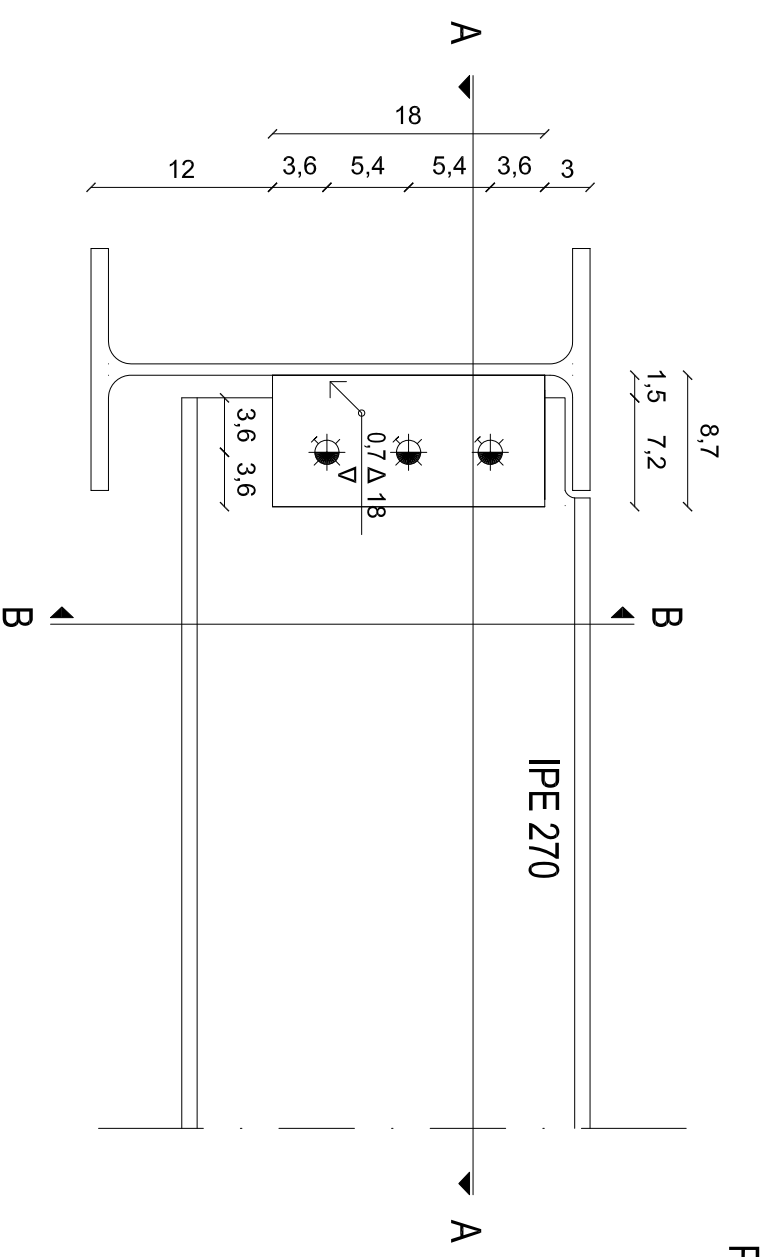

ČLENKASTI SPOJ SEKUNDARNEGA  
NOSILCA NA PRIMARNI NOSILEC

MERILO 1:5

Damjan Sekereš

april 2011

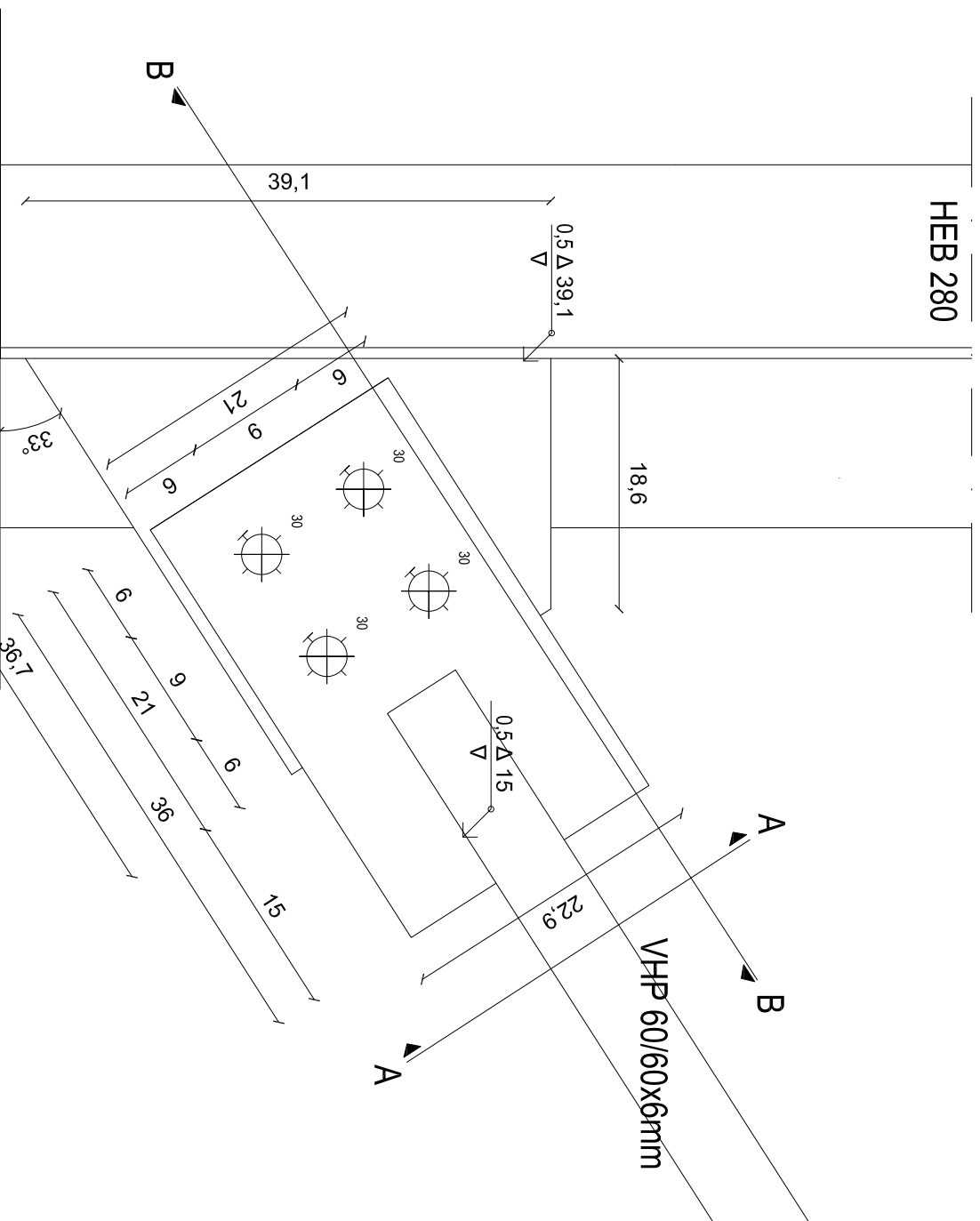

Prerez A-A

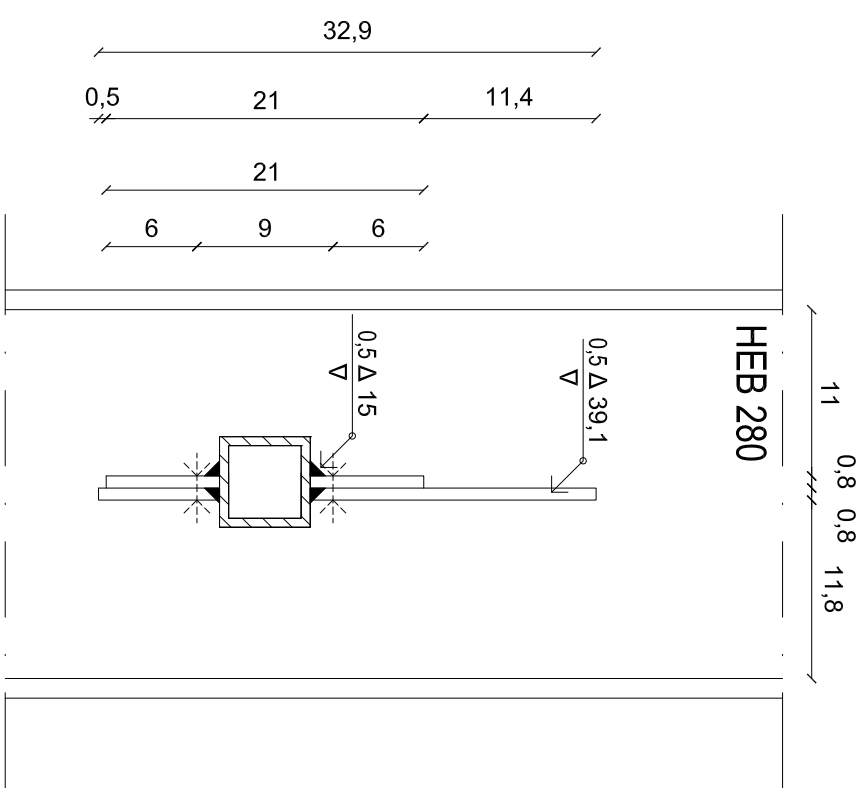

Prerez B-B

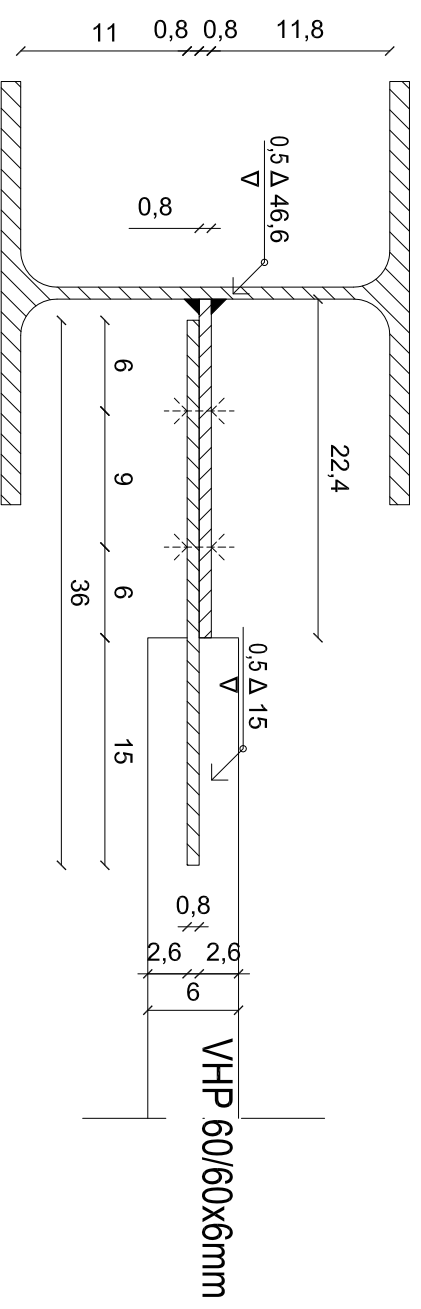

SPOJ POVEZJA NA  
STEBER

MERILO 1:5

Damjan Sekereš

april 2011